



Forest Research Institute

**The current state of Bialowieza Forest
based on the results
of the LIFE+ForBioSensing project**

Sękocin Stary 2022

Forest Research Institute

The current state of Białowieża Forest

**based on the results
of the LIFE+ ForBioSensing project**

Sękocin Stary 2022

Reviewers:

Prof. Bogdan Brzeziecki
Assoc. Prof. Krzysztof Będkowski, Prof. University of Lodz
Prof. Wojciech Grodzki

Copyright by Forest Research Institute, 2022

ISBN 978-83-62830-92-3

The work was received on 12/09/2021
and was accepted by the Publisher on 25/02/2022

Scientific editor: Assoc. Prof. Krzysztof Stereńczak

Technical editorial team: Joanna Szewczykiewicz, EngD, Przemysław Szmit, M.Sc.

Publisher:

Forest Research Institute
Sękocin Stary, 3 Braci Leśnej St., 05-090 Raszyn

Typesetting: Oficyna Wydawnicza Liber Novum

Print: Oficyna Wydawnicza Liber Novum

Cover concept: Assoc. Prof. Krzysztof Stereńczak

Preparation of the visualization for the front page:
Maciej Lisiewicz, M.Sc., Kamil Pilch, M.Sc

Back cover photo: Łukasz Kuberski

Cover texts: Wirginia Duranowska, M.A.

Translation: MD Online Sp. z o.o.

License: Attribution 4.0 International (CC BY 4.0)



Comprehensive monitoring of stand dynamics in Białowieża Forest using remote sensing data

Contents

I. Preliminary issues

1. Introduction (K. Stereńczak, D. Korzybski)
2. Stand history in Białowieża Forest (R. Paluch)
3. Climatic conditions of Białowieża Forest (A. Boczoń, A. Sałachewicz)

II. Status and dynamics of the Białowieża Forest stands

- analysis based on field data

4. Wood resources of Białowieża Forest in 2015–2019 – status and dynamics (S. Miścicki, Ł. Kuberski, R. Paluch, K. Pilch, K. Stereńczak)
5. Status and dynamics of dead wood volume in Białowieża Forest in 2015–2019 based on data from permanent monitoring plots (Ł. Kuberski, R. Paluch, Ż. Piasecka, E. Zin, K. Stereńczak)
6. Tree regeneration in canopy gaps in Białowieża Forest (D. Dobrowolska, Ł. Kuberski, Ż. Piasecka, K. Stereńczak)
7. Dendrochronological reconstruction of stand dynamics in Białowieża Forest (E. Zin, K. Pilch, M. Klisz, A. Bosak, P. Całusińska)
8. Current tree growth in Białowieża Forest – stem circumference changes recorded by dendrometers during the 2016–2020 period (E. Zin, A. Sałachewicz, M. Klisz, K. Szyłak, Ł. Kuberski, K. Pilch)

III. Status and dynamics of Białowieża Forest stands

- analysis based on remote sensing data

9. Use of remote sensing data to assess the dynamics of selected characteristics of Białowieża Forest stands in 2015-2019 (K. Stereńczak, B. Kraszewski, A. Kamińska, Ż. Piasecka, M. Lisiewicz, M. Białczak, M. Mielcarek, A. Modzelewska, R. Sadkowski, K. Kędra)
10. Determination of selected tree biometric characteristics on the basis of a single measurement by terrestrial laser scanning (B. Kraszewski)
11. Determination of selected stand characteristics with analysis of their changes in 2015-2019 using multitemporal terrestrial laser scanning data (K. Kędra)
12. Tree species composition of the Białowieża Forest and its dynamics in the period 2015-2019 (A. Modzelewska)
13. Comprehensive analysis of spruce dieback between 2015 and 2019 in the Białowieża Forest (A. Kamińska, M. Lisiewicz, B. Kraszewski, K. Stereńczak)
14. Modelling of light conditions in PB stands (Ż. Piasecka, M. Białczak, A. Kamińska, K. Stereńczak)
15. Identification and mapping of forest communities of Białowieża Forest using remote sensing data (J.M. Matuszkiewicz, R. Paluch, A. Szulc, M. Mielcarek, M. Lisiewicz, Ł. Kuberski, K. Stereńczak)

IV. Summary and suggestions for further actions

16. Monitoring stand dynamics in the Białowieża Forest - possibilities of using remote sensing, based on the results of the Life+ ForBioSensing project (K. Stereńczak)
17. Promotion of ForBioSensing project results in the public and among project stakeholders (W. Duranowska, D. Korzybski, K. Stereńczak)
18. Replication of project results, networking of beneficiaries and dissemination of the LIFE + Programme (D. Korzybski, W. Duranowska, K. Stereńczak)
19. Project summary (K. Stereńczak, D. Korzybski)
20. Attachment

I. Preliminary issues

1. Introduction

Krzysztof Stereńczak¹, Damian Korzybski¹

Forest Research Institute, Department of Geomatics, Sękocin Stary, 3 Braci Leśnej St., 05-090 Raszyn
{k.sterenczak, d.korzybski}@ibles.waw.pl

For centuries, the Białowieża Forest was a unique and very interesting place, especially for foresters, who could learn various methods of reforestation and forest management here. It was also an important place for ecologists who could observe interesting processes in forest ecosystems here, and for every ordinary person who could learn something about the forests that covered large parts of Poland centuries ago. The area of the Białowieża Forest has always been an object intensively used by science. Research on stand dynamics, habitats and plant communities, population dynamics of various animals and research on fungi was conducted here. The special feature of the research on stand dynamics was the use of sample plots on which measurements of the different development stages of the trees were carried out. Statistical methods were then used to characterise the state and direction of changes in Białowieża Forest..

The project “LIFE+ ForBioSensing PL Comprehensive monitoring of the dynamics of the stands of Białowieża Forest with the use of remote sensing data” was inspired in 2012 by the then Director of the Forest Research Institute, Prof. Dr. hab. Tomasz Zawila-Niedzwiecki. The impetus for the project was the desire to use remote sensing data, mainly airborne laser scanning data, in forest stand analysis. Remote sensing data enable stand characterization at a specific date. Acquisition of data in several periods allowed not only to describe the static situation, but also to characterise changes taking place in the stands of Białowieża Forest. Additionally, this type of data was intended to provide a reference point for analysing the condition of Białowieża Forest in subsequent decades using new methods of data analysis and interpretation.

The project involved the development and application of a monitoring system for Białowieża Forest using ground-based monitoring plots and remote sensing data. The main objective of the project activities was to link multitemporal remote sensing data (in 2015-2019) with the results of various ground measurements to enable and facilitate subsequent monitoring of forest-wide processes. This monitoring generally involved selected elements of stand dynamics and was limited by the capabilities of the specified remote sensing data.

The project established and inventoried 685 permanent sample plots that served as ground-based monitoring plots. It should be emphasized that, for the first time in its history, the ForBioSensing project created a network of field sample plots located objectively on the entire territory of the Polish part of the Białowieża Forest, covering all administrative units and forms of nature conservation. There were 355 plots distributed in a 1300×1300 m grid, with one side rotated in a 330° azimuth (for more details see subsection 1.4 in Chapter 4, see also Fig. 6.2 in Chapter 6). In addition, a number of existing permanent sample plots with longer measurement histories and resulting empirical data were used. These were 160 research plots objectively distributed in the Białowieża National Park (in a grid of about 267×1067 m) (see subsection 1.3 in Chapter 4 with Fig. 6.2 in Chapter 6), and 170 research plots of the Forest Research Institute subjectively distributed in the best preserved fragments of the Polish part of the Białowieża Forest (map 1).

As a result of the activities conducted under the project, the usefulness of individual remote sensing data in monitoring forest associations was reviewed, the characteristics of trees and stands that can be successfully monitored were determined, and the best types of data for analyses of stand dynamics were identified. In addition, based on ground data, the dynamics of all tree generations in the Białowieża Forest were determined, the condition of coarse wood in local tree stands was inventoried, the most extensive dendrochronological material on the territory of the Polish part of the Białowieża Forest to date was analysed, data on recent changes in the stem diameter of the main tree species in the area were collected, the dynamics of regeneration in gaps was analysed, and the phytosociological map of forest communities was prepared.

The results of the project and the effects of all activities were widely promoted to the public. Almost 5 million people were directly informed about the project and/or its activities. A series of videos and radio programs were created as part of the project. Promotion of the project took place at various meetings organised by the project team, as well as at various mass events (e.g., Earth Days) and scientific conferences.

Below are the key facts about the project:

- **Implementation period:** 1.10.2014 – 30.04.2022;
- **Funding Source:** European Commission under the Life+ Instrument, National Fund for Environmental Protection and Water Management and the Forest Research Institute;
- **Contract numbers:** KE: LIFE13 ENV/PL/000048, NFOŚiGW: 485/2014/WN10/OP-NM-LF/D;
- **Amount of funding:** KE: 1 955 251 €; NFOŚiGW: 1 755 616 €; IBL 352 559 €;
- **Beneficiary:** Forest Research Institute.

One of the three most important areas of activity in the ForBioSensing project, in addition to the technical work and promotion of project results, was the ongoing project management process. Any project, especially projects characterised by a large number of interrelated tasks, interactions with numerous stakeholders, a long lead time, a large project team, numerous risks, and multiple financing institutions, required a methodical management approach. Numerous tools were already envisioned for the project at the proposal stage to enable effective management, controlled execution, and achievement of the planned outcomes (products). ForBioSensing's project management was based on selected elements of the PRINCE2 methodology. The project Steering Committee, management, and project team were established. Special emphasis was placed on building an effective project team. As part of the project, more than a dozen project roles and their responsibilities were defined and assigned to individuals. At the time of writing, from the perspective of the project coming to an end, it can be stated with confidence that the proper planning and leadership of a competent and dedicated project team (over 60 people) by the experienced management was one of the key factors that enabled the project to run smoothly and be completed. The second of the most important elements to ensure project implementation was the development of numerous mechanisms to monitor the correctness of the project. The ForBioSensing project was characterized by almost 170 measurable indicators (project outputs, milestones, task progress indicators, meeting indicators), the successive achievement of which within 15 main tasks (task groups) ensured the controlled progress of the project. Another, undoubtedly one of the most important elements, if not the most important, was the planning of effective communication, both formal and informal. In the area of communication, nearly 40 formal reports on the progress of the project were planned to be submitted to the institutions co-financing the project. There were also formal communication channels in the form of numerous registers (risks, issues, lessons learned), frequent cyclical meetings at various levels of project management, and appropriate locations for teams to ensure informal direct communication.

This publication is a summary of the activities undertaken as part of the project. It contains previously unpublished material as well as a summary of activities, particularly using remote sensing data already widely published in scientific journals.

2. Stand history in Białowieża Forest

Rafał Paluch¹

¹ Forest Research Institute, Department of Natural Forests, 6 Park Dyrekcyjny St., 17-230 Białowieża
r.paluch@ibles.waw.pl

Abstract

This chapter presents the history of the forest stands of Białowieża Forest based on comprehensive selected literature. Białowieża Forest is one of the few areas in Europe that is continuously covered with the forest since the Ice Age to the present times. You can find there very well-preserved communities of organisms, that are typical for natural forests and their habitat types. This forest object is characterized by well-preserved, especially in the already protected areas, species structure, age and spatial structure of tree stands, including the presence of a large number of trees with monumental dimensions. The area of this forest complex has been characterized by some intensity of human use over nearly four thousand years. Particularly clear traces of management can be seen in the last 2,000 years or so. The Białowieża Forest may have been influenced by such historical uses as charcoal, potash and tar production, beekeeping, selective use of deciduous trees, and domestic cattle grazing. However, they involved neither long-term or permanent deforestation, nor strong anthropogenic transformation of forest stands in significant areas of Białowieża Forest, which made it possible to preserve its unique values for centuries. Fires were also frequent. Currently, for the past few decades, a significant increase in the share of common hornbeam in reconstructing Białowieża Forest stands has been observed. This species has shown expansion into a variety of habitats, including poor and moderately fertile habitats. Under natural conditions, hornbeam dominated most of the analysed communities that undergo reforestation. On the other hand, the retreat of spruce towards the oligotrophic forest parts was observed – This species has been significantly reduced in all stands. Pine, oak and birch clearly decrease their share in the formation of Białowieża Forest stands, including in the reforestation layer, under different conditions, and under strict and partial protection.

Keywords: forest dynamics, reforestation, species composition

2.1. Introduction

Białowieża Forest is one of the largest and best-preserved forest areas in the lowlands of Central and Eastern Europe. Therefore, this area is an object of extraordinary importance for natural science studies. This is because the forest is an unparalleled research laboratory, allowing for in-depth study of the processes and functioning of natural ecosystems and the population structure of various species of organisms (Sokołowski 1993; Cieslinski 2009; Pawlaczyk 2009; Paluch et al. 2012; Jaroszewicz et al. 2019). The uniqueness and exceptionality on a European scale of this forest community is due, among others, to the preservation of a great diversity of life forms, the presence of natural forest ecosystems and the ecological links between their individual components (Jaroszewicz et al. 2019). Białowieża Forest is dominated by eutrophic habitats, which proves its uniqueness. The total proportion of deciduous forest habitat is nearly 60%. There are only a few percent of coniferous forests and just over 30% of the mixed coniferous forests (Sokolowski 2004).

Białowieża Forest is one of the few areas in Europe continuously covered with forest from the glacial retreat to the present moment (Latalova et al. 2016). According to some authors, natural processes take place over a significant area of it (Wesołowski et al. 2018). Białowieża Forest is one of the few places in Europe where you can find very well-preserved communities of organisms, typical for natural forests and their habitat types. This forest object is characterized by well-preserved, especially in the already protected areas, species structure, age and spatial structure of tree stands, including the presence of a large number of trees with monumental dimensions. (Jaroszewicz et al. 2019; Grzywacz et al. 2017).

About 75% of Białowieża Forest area is currently excluded from direct human interference (including Białowieża National Park, nature reserves, zones for the protection of birds, fungi and other protected organisms, UNESCO zones). Also, in all stands over 100 years of age, no silvicultural and protective treatments are performed. Conservative protection dominates, allowing natural ecological processes to follow. On the other hand, 80% of the area is occupied by protected forest habitats included in Annex I of Council Directive 92/43/EEC, which are important for the whole European Community. These include subcontinental oak-hornbeam forests (9170) and priority habitats, e.g., swampy coniferous forests (91D0), and ash-alder riparian forests (91E0). Białowieża Forest is unquestionably one of the most valuable natural objects of the European Union (Jaroszewicz et al. 2019).

In the studies on the development and dynamics of Białowieża Forest stands, particular attention brings the issue of changes in the species composition, which have been registered for several decades. In the entire Białowieża Forest, including the Białowieża National Park, a clear decrease in the frequency of pine, oak and spruce is recorded, with a simultaneous increase in the share of shadow-bearing species, mainly hornbeam and lime (Bernadzki et al. 1998; Kuijper et al. 2010; Sokolowski 1991, 1999, 2004; Niklasson et al. 2010; Drozdowski et al. 2012; Finger 2015; Zin et al. 2015; Brzeziecki et al. 2016, 2020, 2021; Zine 2016; Spīnu et al. 2020; Gabrysiak et al. 2021). The causes of these changes are likely complex, among the possible ones are climate change, habitat eutrophication (probably strongly related to nitrogen deposition – compare, e.g., Malzahn et al. 2009), human economy, activity of herbivorous mammals or disappearance of fires previously present in the area (Falinski 1986; Sokolowski 1991, 1999, 2004; Bernadzki et al. 1998, 2001; Niklasson et al. 2010; Zin et al. 2015; Brzeziecki et al. 2016, 2020; Spīnu et al. 2020).

Białowieża Forest has been used by mankind with varying intensity for nearly four thousand years. Particularly clear traces of human activity can be seen in the last nearly 2000 years (Latalova et al. 2016; Zapłata and Stereńczak 2016, 2018; Stereńczak et al. 2020). Białowieża Forest may have been significantly influenced by forms of historical use such as agriculture (Zapata and Stereńczak 2016, 2018; Stereńczak et al. 2020), charcoal, potash and tar production, beekeeping (Samojlik et al. 2013), selective use of deciduous trees (Samojlik 2005b; Samojlik et al. 2013) or domestic cattle grazing (Samojlik et al. 2013, 2016). However, the listed forms of traditional use were not associated with either long-term or permanent deforestation, nor with severe anthropogenic transformation of forest stands over significant areas of the forest (Samojlik et al. 2013; Latalova et al. 2016), which has allowed its unique qualities to be preserved for centuries (Jaroszewicz et al. 2019).

As part of the study carried out at the Forest Research Institute in cooperation with the Swedish University of Agriculture (SLU) and the “Belovezhskaya Pushcha” State National

Park, the dynamics of regeneration and development of selected major forest-forming species of Białowieża Forest – primarily Scot’s pine (*Pinus sylvestris* L.) – has been studied in relation to the history of fire disturbance in the coniferous forests habitats in the area over the past several hundred years (Zin 2016). The research was conducted in both parts of Białowieża Forest – in Poland and in Belarus. It was shown that fires were an important factor shaping the structure and species composition of Białowieża Forest stands over the last 400 years. During the period from about 1600 to about 1850, these disturbances occurred very frequently, every few years, then their frequency decreased significantly until they completely disappeared in the first decades of the 20th century (Zin 2016). Based on tree diameter at the first fire scar and fire disturbance-induced incremental responses, it was concluded that the historical fire regime in Białowieża Forest was dominated by low-intensity disturbances that allowed successful natural regeneration of pine. Occasionally, however, very intense fires also occurred in the area, completely altering the age and spatial structure of stands by triggering waves of regeneration for this species (Zin et al. 2015). As fire disturbance frequency decreased, a decrease in effective pine regeneration and an increase in effective spruce regeneration were observed. The disappearance of fire disturbances in Białowieża Forest in the first decades of the 20th century appeared to be equivalent to the end of effective pine regeneration in the studied stands. It has been shown in Białowieża Forest that fire – similar as in the boreal zone – can be seen as a positive factor for pine regeneration in competition with other tree species (such as spruce), also in Central European forests (Niklasson et al. 2010; Zin et al. 2015; Zin 2016).

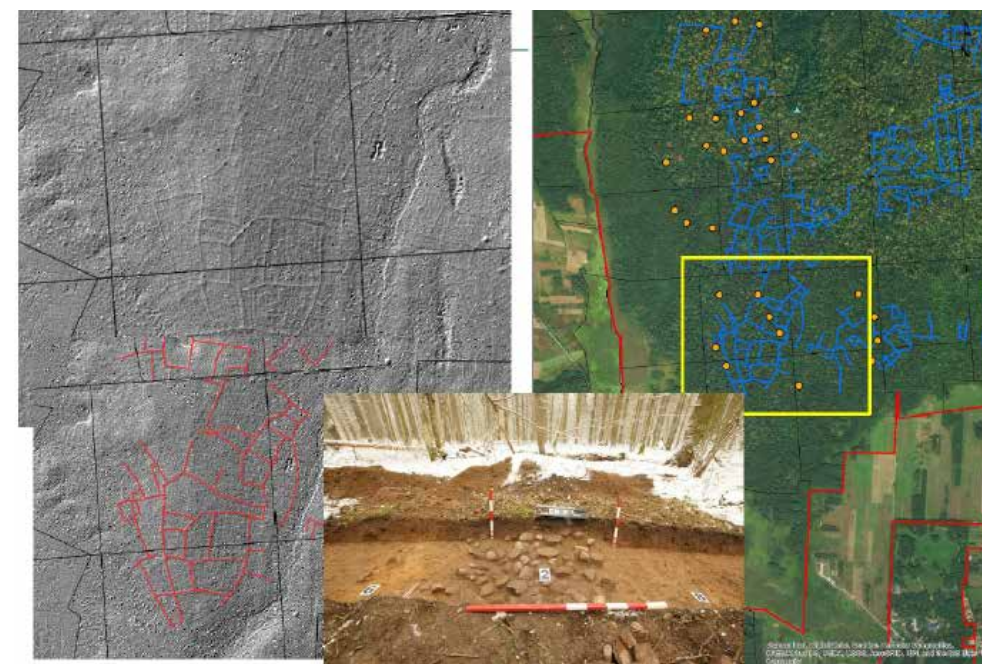

Figure 2.1. Traces of probably agricultural systems in the strictly protected part of the Białowieża National Park (Hilszczański J. and Stereńczak K. 2017. GDSF Inventory)

Human activity very clearly influenced the formation of quantitative proportions of the species composition of tree stands (the share of coniferous species such as pine or spruce in relation to the rest, and deciduous species such as oak) and the relation of forest areas to open spaces (burned areas, meadows, pastures, clear-cuttings, etc.). Undoubted influence, the effects of which continue to this day, was also exerted by agricultural and settlement activity in the area, as well as by the water regulations, and in the recent history of the last century also by conscious forest management (Falinski 1986; Sokolowski 2004). Beekeeping and other activities that selectively influence the formation of forest structure have also played a significant role in the history of forest stands. According to many researchers, Białowieża Forest survived as a large forest complex due to the fact that it was a hunting ground for Polish and Russian rulers for several hundred years (Hedemann 1939; Więcko 1984; Sokolowski 2004; Samojlik 2005a). Shaping the structure of forest stands took place through selective gnawing or deliberate promotion of some species and elimination of others, as well as through forest management lasting for a hundred years with periods of increased intensity. Białowieża Forest has been subject to various forms of use for centuries. Among other things, the forests were used by the Russian Tsar as a game preserve. During World War I, more than 4 million m³ of trees were plundered for timber (6500 ha of clear-cutting). In the interwar period, there were further episodes of plundering the forest. As a result of an agreement signed with the then government of Poland, The Century European Timber Corporation (1924–1929) harvested 2.5 million m³ of timber without restoring the area after clear-cutting (Sokolowski 2004). These sites were subsequently restored by the Polish forestry administration, including spruce of uncertain origin, or regenerated spontaneously. The period of World War II contributed to further damage caused by uncontrolled tree cutting by successive occupiers, also in the area of the present national park. After the war, in the Districts of Białowieża Forest, most of the harvesting was done by clear-cutting, in areas where mainly coniferous species were planted. In addition, until the 1960s, livestock was grazed in many forest stands. Sustainable and multifunctional forest management has been practised since the 1990s (Bernadzki et al. 2012). The work of many generations of foresters has increased the abundance of forest stands from 187 m³ of trees per hectare of forest in 1930 to 330 m³ ha⁻¹ until today (Opinion of the Scientific Council of Forestry 2016).

Matuszkiewicz (2016) writes that in a significant part of Białowieża Forest we are dealing with “the occurrence of biocenoses showing features of systems close to natural ones”. Past forest use and anthropogenic transformations of this unique area show that humans have played an important role in shaping some of its biodiversity, today protected, without which it often cannot survive (Opinion of the Forest Science Council 2016). This is confirmed by many years of research carried out by various scientific institutions, including SGGW in Warsaw and the Forest Research Institute (Brzeziecki et al. 2012, 2018; Paluch 2015).

In the former Strict Reserve of the Białowieża National Park, long-term studies of changes in the species composition and structure of tree stands are currently being carried out on five permanent research plots (transects) designated by Professor T. Włoczewskiego in 1936. The results of systematically conducted measurements now form an extensive database of a unique nature, comprising empirical material that dates back over 80 years and from an area of about 15 ha (Bernadzki et al. 1998). They are the basis for creating ecological models of forest stands and developing forecasts of their development with changing climatic conditions (Brzeziecki 1999). In the study plots, information is systematically collected primarily on the layer of living trees reaching at least 5 cm of DBH (diameter at

breast height). Only on one transect was a single study of the composition and density of the natural reforestation carried out (Zajączkowski 1999), changes in other elements of the phytocenosis over a period of almost 40 years (1959–1998) were elaborated – the vegetation of the forest floor (Paluch 2001a), and lying dead wood was inventoried (Paluch 2001b). Apart from the above-mentioned works, the Department of Natural Forests of the Forest Research Institute conducts research on several dozen permanent plots in Białowieża Forest of the size of 0.25–0.5 ha (distributed in habitat-forest systems typical for the object), including the measurement of breast height of all trees, inventory of regeneration, and phytosociological photo (Sokolowski 1993). In most of the forest communities analysed and in a short period of time, about 40–50 years, there have been significant changes in the species composition of natural stands growing without human interference. It should be emphasized that the study period represented a small part of the history of forest development, and inferences and predictions based on this can only be approximate. The present findings fully confirm previous studies of longer duration (nearly 90 years) (Bernadzki et al. 1998; Brzeziecki 2008; Brzeziecki et al. 2010; Drozdowski et al. 2012), emphasizing at the same time that the irregularities observed apply to the entire Białowieża Forest, including the areas under partial protection. On the basis of the accumulated long-term research material, systematically supplemented with new research plots, the cited authors have grouped tree species in their recent publications, distinguishing small-volume (“endangered”), admixture (“relatively safe”) and “expansive” species. It is noteworthy that in the group of expansive species only hornbeam is currently listed, whereas in previous periods linden and ash also showed such tendencies (Brzeziecki et al. 2012; Drozdowski et al. 2012). In light of the results of other studies from Białowieża Forest (Paluch 2015; Gabrysiak et al. 2021) hornbeam appears to be very expansive, encroaching on both poor and mixed coniferous forest habitats and on wet ash-alder riparian forests. In mixed coniferous forest habitats, it competes strongly with spruce, among others, and its regeneration is at least as numerous as its competitors. How can a Calamagrostio-Piceetum forest complex look like and function, where spruce – that should play the key role in the stand – is replaced by hornbeam, a species that is characterized by completely different ecological properties? The existing data indicate that transitional communities, strongly reminiscent of oak-hornbeam forests, with still evident elements of coniferous forests and few diagnostic species, are formed. If the described trends continue, areas overtaken by hornbeam will completely transform into oak-hornbeam forests. Such a situation is currently observed in the case of the thermophilous bastard balm-hornbeam forest community, in which the vast majority of the examined plots have been transformed into the typical oak-hornbeam forest. In this community, there has been a multiple increase in hornbeam density in all stand layers, including seedlings, saplings, and the second layer, over the past 15 years. This species has displaced all of its competitors from the restoration layer, including the spruce that dominated there at the beginning of the study, nearly 40 years ago (Paluch, Zin 2013).

Analysing the long-term dynamics of linden regeneration and its promotion to higher stand layers allows us to conclude that the expansion of this species is currently inhibited and limited to optimal and suboptimal (oak-hornbeam) habitats (Gabrysiak et al. 2021). Several decades ago, it was much more pronounced, as confirmed by earlier work (Kowalski 1982; Bernadzki et al. 1998).

In the case of ash, considered a dozen or so years ago as an expansive species, dominant or co-dominant in alder-ash riparian forests (Brzeziecki, Żybura 1998; Bernadzki et al. 1998;

Paluch 2001; Drozdowski et al. 2012), it can be concluded that its dynamic status has changed dramatically. Ash has now become a highly endangered species, being in regression, similar to elm trees once were. At the beginning of the 20th century there began an unprecedented phenomenon of mass dying of ash and whole stands with the participation of this species. This phenomenon is not dying out (Gil et al. 2011). It has been proven that, also under natural conditions, ash has separated from all stand layers. There was also a lack of restoration of this species. In several cases, all of the ash trees in the study plot were found to have separated in just 15 years. We don't know when the ash tree will begin to regenerate, so far there is no indication of that. Certainly, the current health of the ash tree is worrying, because the condition of the few surviving specimens is bad. The condition of ash described here appears to be more critical than in analyses performed in the Strict Reserve of the Białowieża National Park (Brzeziecki et al. 2012). The cited authors found the death of the species mostly among young trees, less frequently in the whole population.

Among the large group of species with a currently clearly declining proportion in Białowieża Forest are pine and oak (Brzeziecki et al. 2012), very important species for the functioning of many forest communities. It was confirmed that the share of these species was decreasing and that there was no regeneration of pine and very low abundance of oak. The complete withdrawal of pine from habitats theoretically optimal for it, namely fresh and mixed coniferous forests, is noteworthy. Even when natural regeneration of pine trees did occur, which happened only once in 1975, it then gradually disappeared. Occasionally, this species was found growing up to higher breast height classes. On the aforementioned 1936 transects of the Department of Silviculture of the Warsaw University of Life Sciences (SGGW), a tree above 5 cm in breast height of pine has not been recorded in almost 90 years of research (Brzeziecki et al. 2012). Drozdowski (2014) reported that oak regeneration systematically occurs in different habitat conditions of Białowieża Forest, but does not find suitable conditions for growth. On the other hand, our own research (Paluch 2015) showed that seedlings and low oak saplings, although occurring, especially paradoxically most abundantly in poor coniferous forests and mixed coniferous forests habitats, did not advance to higher stand layers, which indicates the ineffectiveness of oak regeneration under current conditions.

Between 1975 and 1986, the changes in the species composition of Białowieża Forest stands discussed above were generally very small, suggesting an acceleration of their rate in the last 15 years. When comparing all the forest communities studied, it was found that the greatest changes occurred in the bastard balm-hornbeam forest. In terms of the rate and magnitude of changes in the species composition of forest stands, the forest communities studied can be ranked as follows (in descending order): bastard balm-hornbeam forest, fresh coniferous forest, fresh mixed coniferous forest, ash-alder riparian forests and typical oak-hornbeam forest. It has been observed that a low rate of change was sustained in the oak-hornbeam throughout the study period (Paluch 2015; Miścicki 2016).

It can be said that currently the dominant phenomenon, having the most significant impact on the image of Białowieża Forest and ecological conditions in it, is the expansion of hornbeam, which certainly starts a sequence of changes in the whole forest ecosystem. The encroachment of hornbeam on habitats where this species did not occur before, or was small, causes a unification of the species composition of forest communities, making them more similar to oak-hornbeam (Paluch 2001; Sokolowski 2004; Bernadzki et al. 1998; Brzeziecki

2008; Brzeziecki et al. 2012). The cited authors wrote during the past decade that the expansion of hornbeam was not yet over.

The current picture of Białowieża Forest, characterized by high biological diversity, is a resultant not only of natural processes, but also of many centuries of human activity (e.g., Kowalski 1982; Bernadzki et al. 1998; Sokolowski 2004). An underestimated role may have been played by fires, grazing, burning of potash and charcoal, very high amounts of forest animals or other factors, including human activities, that significantly modified the species composition of tree stands and possibilities of regeneration of individual tree species. As a result of the superimposition of various historical, global, and anthropogenic phenomena, significant changes were found in a relatively short period of time, which were not predicted by the former forecasts of the great researchers of the Forest from the first half of the last century (Paczoski 1930; Matuszkiewicz 1952).

Current forecasts indicate a continuation of hornbeam expansion, with the gradual receding of other tree species important for biodiversity, such as pine and oak (Brzeziecki et al. 2016, 2020, 2021; Gabrysiak et al. 2021). All protection activities for the nature of Białowieża Forest should take into account its natural and cultural uniqueness on the European scale resulting both from its natural conditions and from the existing land use, which is connected with a certain part of biodiversity of Białowieża Forest.

References

- Bernadzki E., Bolibok L., Brzeziecki B., Zajączkowski J., Żybura H. 1998. Compositional dynamics of natural forests in the Białowieża National Park, northeastern Poland. *Journal of Vegetation Science*, 9: 229–238.
- Bernadzki E., Brzeziecki B., Matuszkiewicz J. M., Stępień E. 2012. Problem Puszczy Białowieskiej z punktu widzenia nauk leśnych i przyrodniczych. Maszynopis. Ekspertyza wykonana na zlecenie Ruchu Obrony Lasów Polskich, Warszawa.
- Bernadzki E., Brzeziecki B., Rabczuk A. 2001. Raumzeitliche Dynamik des Durchmesserzuwachses in natürlichen Mischbeständen des Białowieża-Urwalds. *Beiträge für Forstwirtschaft und Landschaftökologie*, 35(4): 166–170.
- Brzeziecki B. 2008. Wieloletnia dynamika drzewostanów naturalnych na przykładzie dwóch zbiorowisk leśnych Białowieskiego Parku Narodowego: Pino-Quercetum i Tilio-Carpinetum. *Studia Naturae*, 54, II: 9–22.
- Brzeziecki B., Drozdowski S., Bielak K., Czacharowski M., Zajączkowski J., Buraczyk W. & Gawron L. 2021. A demographic equilibrium approach to stocking control in mixed, multiaged stands in Białowieża Forest, northeast Poland. *Forest Ecology and Management*, 481: 118694.
- Brzeziecki B., Keczyński A., Zajączkowski J., Drozdowski S., Gawron L., Buraczyk W., Bielak K., Szeligowski H., Dzwonkowski M. 2012. Zagrożone gatunki drzew Białowieskiego Parku Narodowego (Rezerwat Ścisły). *Sylwan*, 156(4): 252–261.

- Brzeziecki B., Pommerening A., Miścicki S., Drozdowski S. & Żybura H. 2016. A common lack of demographic equilibrium among tree species in Białowieża National Park (NE Poland): evidence from long-term plots. *Journal of Vegetation Science*, 27: 460–467.
- Brzeziecki B., Woods K., Bolibok L., Zajączkowski J., Drozdowski S., Bielak K. & Żybura H. 2020. Over 80 years without major disturbance, late-successional Białowieża woodlands exhibit complex dynamism, with coherent compositional shifts towards true old-growth conditions. *Journal of Ecology*, 108: 1138–1154.
- Brzeziecki B., Żybura H. 1998. Naturalne zmiany składu gatunkowego i struktury pierścni na siedlisku olsu jesionowego w okresie 47 lat. Sukcesja czy regeneracja? *Sylwan*, 141(4): 19–31.
- Drozdowski S., Brzeziecki B., Żybura H., Żybura B., Gawron L., Buraczyk W., Zajączkowski J., Bolibok L., Szeligowski H., Bielak K., Widawska Z. 2012. Wieloletnia dynamika starodrzewów w zagospodarowanej części Puszczy Białowiejskiej: gatunki ekspansywne i ustępujące. *Sylwan*, 156(9): 663–671.
- Drozdowski S. 2014. Modelowanie procesów odnowieniowych w lesie naturalnym. *Rozprawy i Monografie*. Warsaw University of Life Science Press.
- Faliński, J.B. 1986. Vegetation Dynamics in Temperate Lowland Primeval Forest. *Ecological Studies in Białowieża Forest*. Dr W. Junk Publishers, Dordrecht.
- Gil W., Łukaszewicz J., Paluch R., Zachara T. 2011. Jesion wyniosły – zagrożenia i hodowla. PWRiL Warszawa.
- Gabrysiak K.A., Paluch R. & Gawryś R. 2021. 30-Year Changes in Oak-Hornbeam Forest after Windthrow. *Forests*, 12: 600.
- Jaroszewicz B., Cholewińska O., Gutowski J.M., Samojlik T., Zimny M. & Latałowa M. 2019. Białowieża Forest—A Relic of the High Naturalness of European Forests. *Forests*, 10: 849.
- Kowalski M. 1982. Rozwój drzewostanów naturalnych na powierzchni badawczej w Białowiejskim Parku Narodowym. *Rozprawy Nauk. i Monogr. SGGW Warszawa*.
- Kowalski M. 1991. Climate—a changing component of forest site. *Folia Forestalia Polonica Series A-Forestry*, 33: 15–22.
- Kuijper D.P.J., Jędrzejewska B., Brzeziecki B., Churski M., Jędrzejewski W. & Żybura H. 2010. Fluctuating ungulate density shapes tree recruitment in natural stands of the Białowieża Primeval Forest, Poland. *Journal of Vegetation Science*, 21: 1082–1098.
- Latałowa M., Zimny M., Pędziszewska A., Kupryjanowicz M. 2016. Postglacjalna historia Puszczy Białowiejskiej – roślinność, klimat i działalność człowieka. *Parki Narodowe i Rezerwaty Przyrody*, 35(1): 3–49.
- Malzahn E., Kwiatkowski W. & Pierzgałski E. 2009. Przyroda nieożywiona. [In:] *Okołów C., Karaś M. & Bołbot A. (eds.) Białowiejski Park Narodowy. Poznać – Zrozumieć – Zachować: 17–36*. Białowiejski Park Narodowy, Białowieża.
- Matuszkiewicz J. 2016. Ogólna opinia odnośnie zagadnień zawartych w przesłanym w dniu 14 stycznia br. tekście: “Informacja o aktualnej sytuacji w Puszczy Białowiejskiej oraz proponowane działania”. Opinia dla Regionalnej Dyrekcji Lasów Państwowych w Białymstoku. Milanówek.
- Matuszkiewicz W. 1952. Zespoły leśne Białowiejskiego PN. Wyd. UMCS Lublin.
- Niklasson M., Zin E., Zielonka T., Feijen M., Korczyk A.F., Churski M., Samojlik T., Jędrzejewska B., Gutowski J.M. & Brzeziecki B. 2010. A 350-year tree-ring fire record from Białowieża Primeval Forest, Poland: implications for Central European lowland fire history. *Journal of Ecology*, 98: 1319–1329.
- Opinia Rady Naukowej Leśnictwa przy Prezesie Rady Ministrów Rzeczypospolitej Polskiej w sprawie zamierania drzewostanów świerkowych na obszarze nadleśnictw Białowieża, Browsk i Hajnówka wchodzących w skład Leśnego Kompleksu Promocyjnego „Puszcza Białowiejska”. J. Sowa, P. Łakomy, B. Brzeziecki, J. Hilszczański, T. Kowalski, S. Miścicki, J. Modrzyński, J. Starzyk, S. Małek, Warszawa, 11.03.2016 r.
- Paczoski J. 1930. *Lasy Białowieży*. Państwowa Rada Ochrony Przyrody. Poznań.
- Paluch R. 2001. Zmiany zbiorowisk roślinnych i typów siedlisk w drzewostanach naturalnych Białowiejskiego Parku Narodowego. *Sylwan*, 145(10): 73–81.
- Paluch R. 2015. Wieloletnie zmiany składu gatunkowego drzewostanów naturalnych w Puszczy Białowiejskiej. *Sylwan*, 159(4): 278–288.
- Paluch R., Zin E. 2013. Wieloletnie zmiany roślinności wybranych zbiorowisk leśnych Puszczy Białowiejskiej. *Maszynopis. ECLN Białowieża*.
- Samojlik T. 2005a. Ochrona i łowy. *Puszcza Białowiejska w czasach królewskich*. Zakład Badania Ssaków Polskiej Akademii Nauk, Białowieża.
- Samojlik T. 2005b. A tree of many uses - the history of small-leaved lime (*Tilia cordata*) in Białowieża Primeval Forest. *Rocznik Dendrologiczny*, 53: 55–64.
- Samojlik T., Fedotova A., Kuijper D.P.J. 2016. Transition from traditional to modern forest management shaped the spatial extent of cattle pasturing in Białowieża Primeval Forest in the nineteenth and twentieth centuries. *Ambio*, 45: 904–918.
- Samojlik T., Rotherham I.D. & Jędrzejewska B. 2013. Quantifying Historic Human Impacts on Forest Environments: A Case Study in Białowieża Forest, Poland. *Environmental History*, 18: 576–602.
- Sokołowski A.W. 1991. Changes in species composition of forest associations in the nature reserves of the Białowieża Forest. *Ochrona Przyrody*, 49: 63–78.
- Sokołowski A.W. 1993. Fitosocjologiczna charakterystyka zbiorowisk leśnych Białowiejskiego Parku Narodowego. *Parki Narodowe i Rezerwaty Przyrody*, 12(3): 5–190.
- Sokołowski A.W. 1999. Succession of forest communities in the Starzyna reserve in the Białowieża Forest. *Parki Narodowe i Rezerwaty Przyrody*, 18: 31–59.

Sokołowski A.W. 2004. Lasy Puszczy Białowieskiej. CILP Warszawa.

Spînu A.P., Niklasson M. & Zin E. 2020. Mesophication in temperate Europe: A dendrochronological reconstruction of tree succession and fires in a mixed deciduous stand in Białowieża Forest. *Ecology and Evolution*, 10: 1029–1041.

Stereńczak K., Zapłata R., Wójcik J., Kraszewski B., Mielcarek M., Mitelsztedt K., Białczak M., Krok G., Kuberski Ł., Markiewicz A., Modzelewska A., Parkitna K., Piasecka Z., Pilch K., Rzczycki K., Sadkowski R., Wietecha M., Rysiak P., von Gadow K., Cieszeński C.J. 2020. ALS-Based Detection of Past Human Activities in the Białowieża Forest—New Evidence of Unknown Remains of Past Agricultural Systems. *Remote Sensing*, 12(16), 2657. <https://doi.org/10.3390/rs12162657>.

Wesołowski T., Gutowski J.M., Jaroszewicz B., Kowalczyk R., Niedziałkowski K., Rok J., Wójcik J. M. 2018. Park Narodowy Puszczy Białowieskiej – ochrona przyrody i rozwój lokalnych społeczności. [In:] *www.forestbiology.org*, 2: 1–28. http://www.forestbiology.org/articles/FB_05.pdf.

Zapłata R., Stereńczak K. 2016. Puszcza Białowieska, LiDAR i dziedzictwo kulturowe – zagadnienia wprowadzające. *Raport*, 11: 239–255.

Zapłata R., Stereńczak K. 2018. Archaeological heritage in forested areas – challenges, problems and solutions. *Raport*, 13: 217–227.

Zin E. 2016. Fire history and tree population dynamics in Białowieża Forest, Poland and Belarus. PhD, Swedish University of Agricultural Sciences.

Zin E., Drobyshev I., Bernacki D., Niklasson M. 2015. Dendrochronological reconstruction reveals a mixed-intensity fire regime in *Pinus sylvestris*-dominated stands of Białowieża Forest, Belarus and Poland. *Journal of Vegetation Science*, 26(5): 934–945.

3. Climatic conditions of Białowieża Forest

Andrzej Boczoń¹, Agata Salachewicz²

¹ Forest Research Institute, Department of Forest Ecology, Sękocin Stary, 3 Braci Leśnej St., 05-090 Raszyn

² Forest Research Institute, Department of Natural Forests, 6 Park Dyrekcyjny St., 17-230 Białowieża {a.boczon, a.salachewicz}@ibles.waw.pl

Abstract

Climatic conditions are among the most important habitat factors that determine the development and persistence of ecosystems. The document analyses meteorological parameters in the period 1951–2019 measured at the station of the Institute of Meteorology and Water Management - National Research Institute (IMGW) in Białowieża. A large impact of climate warming on individual meteorological variables dependent on air temperature was demonstrated. The average air temperature for the considered period was 6.7°C with a clear trend of temperature increase of 0.34°C/10 years. The temperature increase refers to the average temperatures of all months of the year, as well as to the minimum and maximum temperatures. Higher air temperatures extended the meteorological growing season by 16 days, mainly due to an earlier start of the growing season. Analysis of the frequency of days in relation to temperature showed that climate warming resulted in a decrease in the number of frost days per year by 29 and an increase in the number of hot days by 19. Higher temperatures in winter months lead to fewer days with snow cover in the Białowieża Forest. From 1951 to 2019, the number of days with snow cover decreased by 34.

Keywords: climate, meteorological conditions, precipitation, air temperature

3.1. Introduction

The climate of the Białowieża Forest is classified as temperate continental, cool with Atlantic influence. According to the classification of Romer (1949), the territory of the Białowieża Forest is located in the climatic zone of the region "C" of the Land of the Great Valleys, in the Chełmsko-Podlaski Land. In one of the more recent classifications, based on the average number of days with a certain weather type, Woś (1996) assigned the Białowieża Forest to the Masurian-Podlaskie region, which includes the eastern part of the Masurian Lake District and part of Podlaskie. Only part of this region lies within the borders of Poland, and it extends further east and north. The region is characterized by the relatively highest frequency of the coldest weather, i.e. days with very cold weather, very cold and sunny weather, very cold and cloudy weather at the same time. It also has the relatively highest number of days with fairly cold weather. On the other hand, the lowest frequency in this part of the country marks days with cool, cloudy, without rain and with rain. Low frequency also characterizes days with moderately warm, sunny weather without rain (Woś 1996).

3.2. Materials and Methods

The study is based on data from the meteorological station of the Institute of Meteorology and Water Management (IMGW), located in Białowieża at a point with coordinates: 52°42.43'N, 23°50.87'E. The data used are available on the website: danepubliczne.imgw.pl. Data from the years 1951-2019 were analysed. Since some measured data from 1956 were missing, this year was excluded from the analysis of air temperature and growing seasons.

For the whole period, the average daily air temperature was calculated from measurements at 2 m height according to the following formula:

$$T_{\text{average}} = (T_{\text{min}} + T_{\text{max}} + T_{6\text{a.m.}} + T_{6\text{p.m.}}) / 4$$

where:

T_{min} – minimum air temperature during the day,

T_{max} – maximum air temperature during the day,

$T_{6\text{a.m.}}$ – air temperature at 6:00 am,

$T_{6\text{p.m.}}$ – air temperature at 18:00.

Recalculation of mean values was aimed at standardization of data due to changes in the method of calculation of average daily temperature by IMGW during the considered period.

The analysis of air temperature and atmospheric precipitation was carried out for the values of annual average, monthly average, summer half-year average, which included the months from May to October, winter half-year average calculated from November of the previous year to April of the year under consideration.

An analysis of days with ground frosts was conducted, which were classified when the minimum temperature at ground level was below 0°C and the maximum temperature above 0°C (Woś 2010; Kossowska-Cezak 2003; Tomczyk 2015). This paper considers the number of days with frost in the period from April to October from 1973 to 2019, for which systematic measurements of temperature near the ground level were conducted. Based on the values of minimum air near the ground, based on the work of Dragańska et al. (2004) and Tomczyk (2015), frosts were separated: mild (t min from 0°C to -2.0°C), moderate (t min from -2.1°C to -4°C), severe (t min from -4.1°C to -6°C) and very severe (t min below -6°C).

The start and end of the Meteorological Growing Season (MGS) and the Forest Growing Season (FGS) were calculated using the method of Huculak and Makowiec (Bartoszek et al. 2012). In both cases, the beginning of the growing season was determined based on the first day with an average temperature equal to or higher than the threshold temperature, from which the cumulative deviations from the average daily temperature did not reach negative

values until the end of the first half of the year. The end of the growing season is the last day with a temperature greater than or equal to the threshold temperature, from which the cumulative series of daily average temperature deviations from the threshold temperature reaches no positive values until the end of the year. The threshold temperature for the meteorological growing season is 5°C.

The division of days with weather types based on air temperature was done after Woś (1996):

- hot weather ($T_{\text{mean}} > 25.0^\circ\text{C}$, $T_{\text{min}} > 0^\circ\text{C}$, $T_{\text{max}} > 0^\circ\text{C}$)
- very warm weather ($T_{\text{mean}} 15.1\text{-}25.0^\circ\text{C}$, $T_{\text{min}} > 0^\circ\text{C}$, $T_{\text{max}} > 0^\circ\text{C}$)
- moderately warm weather ($T_{\text{average}} 5.1\text{-}15.0^\circ\text{C}$, $T_{\text{min}} > 0^\circ\text{C}$, $T_{\text{max}} > 0^\circ\text{C}$)
- cool weather ($T_{\text{mean}} 0.1\text{-}5.0^\circ\text{C}$, $T_{\text{min}} > 0^\circ\text{C}$, $T_{\text{max}} > 0^\circ\text{C}$)
- frosty weather moderately cool ($T_{\text{average}} > 5.0^\circ\text{C}$, $T_{\text{min}} \leq 0^\circ\text{C}$, $T_{\text{max}} > 0^\circ\text{C}$)
- very cold frost weather ($T_{\text{mean}} 0.1\text{-}5.0^\circ\text{C}$, $T_{\text{min}} \leq 0^\circ\text{C}$, $T_{\text{max}} > 0^\circ\text{C}$)
- frosty weather moderately cold ($T_{\text{average}} 0.0^\circ\text{C} - (-5.0)^\circ\text{C}$, $T_{\text{min}} \leq 0^\circ\text{C}$, $T_{\text{max}} > 0^\circ\text{C}$)
- very cold frosty weather ($T_{\text{mean}} < -5.0^\circ\text{C}$, $T_{\text{min}} \leq 0^\circ\text{C}$, $T_{\text{max}} > 0^\circ\text{C}$)
- moderately frosty weather ($T_{\text{mean}} 0,0 - (-5.0)^\circ\text{C}$, $T_{\text{min}} \leq 0^\circ\text{C}$, $T_{\text{max}} \leq 0^\circ\text{C}$)
- quite cold weather ($T_{\text{mean}} -5.1 - (-15.0)^\circ\text{C}$, $T_{\text{min}} \leq 0^\circ\text{C}$, $T_{\text{max}} \leq 0^\circ\text{C}$)
- pogoda bardzo mroźna ($T_{\text{mean}} < -15.0^\circ\text{C}$, $T_{\text{min}} \leq 0^\circ\text{C}$, $T_{\text{max}} \leq 0^\circ\text{C}$)

Variation of total annual atmospheric precipitation was characterised by the criterion introduced by Kaczorowska (1962):

- extremely dry year (half-year) - precipitation less than 50.0% of the multi-year average precipitation,
- very dry year (half-year) - precipitation from 50.1% to 75.0% of the average precipitation,
- dry year (half-year) - precipitation from 75.1% to 89.9% of the average precipitation,
- average year (half-year) - precipitation in the range of 90.0% - 110.0% of the average precipitation,
- wet year (half-year) - precipitation between 110.1% and 125.0% of the average precipitation,
- very wet year (half-year) - precipitation in the range from 125.1% to 149.9% of the average precipitation,
- extremely wet year (half-year) - precipitation exceeding 150.0% of the average precipitation.

The number of days with snow cover was counted for winter half-years, i.e., from November of the first year to April of the second year, which necessitated the presentation of the analysis for the period 1952–2019.

Annual precipitation totals in Białowieża were compared with precipitation measured in the same region, i.e. at the measuring stations and precipitation stations of the Institute of Meteorology and Water Management in Hajnówka, Narew, Klejniki and Brańsk (data provided by the Institute of Meteorology and Water Management on the danepubliczne.imgw.pl website were used).

The trend of changes in meteorological parameters between 1951 and 2019 was tested with the non-parametric Mann-Kendall test using the Makesens 1.0 software developed at the Finnish Meteorological Institute (Salmi et al. 2002). The non-parametric method of Sen (Sen 1968) was used to estimate trends in the time series. The advantage of the methods used is that data with missing values can be used and the data do not have to follow a specific distribution. In addition, Sen's method is not greatly affected by individual data errors or outliers (Salmi et al. 2002). Both methods are described in detail by Salmi et al. (2002).

3.3. Results and discussion

During the period 1951–2019, the average annual air temperature in Białowieża was 6.7°C. The coldest month was January with an average air temperature of -4.4°C, while the warmest month was July (17.7°C). The average temperature of the summer half-year (V-X) was 13.6°C and the average temperature of the winter half-year was -1.5°C. During the studied period there was a high variability of average annual temperatures. The coolest year was 1969, when the average temperature was 4.4°C, while the warmest year was 2019, with an average temperature of 9.0°C. The warmest summer period was 2018, when the average temperature was 15.6°C. During the study period, the average temperature of the summer half-year was above 15°C (15.3°C) only in 2019. The lowest average temperature of the summer half-year was 11.6°C and was measured in 1962.

Between 1906 and 2005, the global average temperature increased by 0.74°C (Solomon et al. 2007). This change is similar to that in the Northern Hemisphere, where air temperature showed a significant positive linear trend from 1961 to 2005 (Brohan et al. 2006). The results for Białowieża are higher than these data, but are consistent with the study by Christiansen et al. (2007), who suggest that the average annual air temperature in Central Europe is likely to be above the global average. Studies conducted in other Central European countries also indicate a greater increase in temperature compared to global changes. Average air temperatures in the Czech Republic show a statistically significant increase of 0.27°C per 10 years over the period 1961-2005 (Brázdil et al. 2009). Climate warming in Białowieża between 1949 and 2019 is comparable to climate change observed throughout Central Europe.

The rate of air temperature increase in Białowieża between 1951 and 2019 was 0.34°C/10 years. During this period, the temperature increase calculated from the Sens trend was +2.3°C.

The temperature increase applies to all temperatures studied: maximum, minimum, and interval averages, and most of the changes shown were statistically significant (Tab. 3.1). Monthly average air temperatures showed the highest increase in February (+3.2°C),

March (+4.0°C), and April (+3.0°C). The lowest temperature increase of +0.7°C was recorded for October. The strong increase in monthly average temperatures resulted in an increase of 2.0°C in the summer half-year and 2.6°C in the winter half-year.

Climate warming affects meteorological features that depend on air temperature, such as the length of the meteorological growing season, the occurrence of cold and hot days, and the occurrence of ground frost. There is a clear trend of increasing meteorological growing season (MGS) in Białowieża in the period 1951–2019 (Fig. 3.2). The mean (MGS) during the considered period was 204 days. The shortest was recorded in 1992 with 168 days and the longest in 2010 with 245 days. It is noteworthy that only in the 21st century the length of the MGS exceeded 230 days - in 2004, 2007, 2010 and 2019 (Fig. 3.2).

The lengthening of the growing season is observed throughout the country. The average length of the growing season in Poland was 224 days in 1971–2010 (Tomczyk et al. 2016). Nieróbca et al. (2013) report that the growing season in Poland was 8 days longer from 2001 to 2009 than from 1971 to 2000. Tomczyk et al. (2016) indicate that the changes in the length of the MGS in the northeast are due to its increasingly earlier onset. In Białystok, the MGS lengthened by almost 5 days between 1971 and 2010, due to an earlier onset of almost 3 days and a later end of almost 2 days. The study showed that in Białowieża the length of the growing season increased by 16 days between 1951 and 2019, which was practically influenced only by the earlier onset of the MGS, which changed by 15 days over the analysed 69 days (Tab. 3.1). The process of lengthening MGS will continue in the future - the analysis of changes in MGS by climate scenarios showed that by 2030 the growing season in central Poland will be 10-14 days longer than in 1971–2000 and 18-27 days longer by 2050 (Nieróbca et al. 2013).

The classification of Polish climate based on the frequency of occurrence of weather types (Woś 1996), made on the basis of data from the period 1951-1980, showed that in the climatic region where Białowieża is located, the most frequent weather in Poland is frosty and very frosty. An analysis of the number of days with very cold, quite cold and moderately cold weather types and moderately warm, very warm and hot weather types was performed. The results show a systematic decrease in the occurrence of days with freezing weather types and a steady increase in the number of days with warm weather types (Fig. 3.3). During the 70-year period considered, the number of cold days decreased by 29 days, while the number of warm days increased by 19 (Tab. 3.1).

Table 3.1. Summary of Mann-Kendall test and Sen's slope estimation

Meteorological parameter	Analysis period	Number of years	Z-value	Significance trend ^{a)}	Linear correlation equation by Sen's method	Change in the period
temp max	1951-2019	69	3.34	***	$f(\text{year}) = 0.040 * (\text{year} - 1951) + 29.70$	+2.7oC
temp min	1951-2019	69	1.03	n.s.	$f(\text{year}) = 0.031 * (\text{year} - 1951) - 24.53$	+2.1oC
mean temp	1951-2019	68	6.08	***	$f(\text{year}) = 0.034 * (\text{year} - 1951) + 5.61$	+2.3oC
temp IX-IV	1952-2019	67	3.34	***	$f(\text{year}) = 0.039 * (\text{year} - 1951) - 2.75$	+2.6oC
temp V-X	1951-2019	68	6.08	***	$f(\text{year}) = 0.029 * (\text{year} - 1951) + 12.55$	+2.0oC
temp I	1951-2019	68	1.49	n.s.	$f(\text{year}) = 0.031 * (\text{year} - 1951) - 4.91$	+2.1oC
temp II	1951-2019	68	2.18	*	$f(\text{year}) = 0.047 * (\text{year} - 1951) - 4.73$	+3.2oC
temp III	1951-2019	68	3.49	***	$f(\text{year}) = 0.059 * (\text{year} - 1951) - 1.26$	+4.0oC
temp IV	1951-2019	68	4.33	***	$f(\text{year}) = 0.044 * (\text{year} - 1951) + 5.311$	+3.0oC
temp V	1951-2019	68	3.60	***	$f(\text{year}) = 0.041 * (\text{year} - 1951) + 11.019$	+2.8oC
temp VI	1951-2019	68	3.40	***	$f(\text{year}) = 0.028 * (\text{year} - 1951) + 14.957$	+1.9oC
temp VII	1951-2019	68	3.98	***	$f(\text{year}) = 0.036 * (\text{year} - 1951) + 16.47$	+2.4oC
temp VIII	1951-2019	68	4.59	***	$f(\text{year}) = 0.037 * (\text{year} - 1951) + 15.125$	+2.5oC
temp IX	1951-2019	68	2.59	**	$f(\text{year}) = 0.021 * (\text{year} - 1951) + 10.88$	+1.4oC
temp X	1951-2019	68	1.14	n.s.	$f(\text{year}) = 0.011 * (\text{year} - 1951) + 6.35$	+0.7oC
temp XI	1951-2019	68	1.77	+	$f(\text{year}) = 0.021 * (\text{year} - 1951) + 1.424$	+1.4oC
temp XII	1951-2019	68	2.16	*	$f(\text{year}) = 0.034 * (\text{year} - 1951) - 2.703$	+2.3oC
Length of MGS	1951-2019	69	2.08	*	$f(\text{year}) = 0.237 * (\text{year} - 1951) + 197.81$	+16 days
Beginning of MGS	1951-2019	69	-3.05	**	$f(\text{year}) = -0.215 * (\text{year} - 1951) + 103.6$	-15 days
End of MGS	1951-2019	69	-0.78	n.s.	$f(\text{year}) = 0,0 * (\text{year} - 1951) + 303.0$	0 days
Number of days with cold weather	1951-2019	69	-3.75	***	$f(\text{year}) = -0.429 * (\text{year} - 1951) + 98.43$	-29 days
Number of days with warm weather	1951-2019	69	4.62	***	$f(\text{year}) = 0.286 * (\text{year} - 1951) + 197.29$	+19 days
Number of days with ground frost	1973-2019	47	-2.12	*	$f(\text{year}) = -0.195 * (\text{year} - 1973) + 43.78$	-9 days
Precipitation I-XII	1951-2019	69	1.06	n.s.	$f(\text{year}) = 0.791 * (\text{year} - 1951) + 592.16$	+54 mm
Precipitation V-X	1952-2019	68	0.50	n.s.	$f(\text{year}) = 0.257 * (\text{year} - 1952) + 385.78$	+17mm
Precipitation XI-IV	1952-2019	68	1.23	n.s.	$f(\text{year}) = 0.400 * (\text{year} - 1952) + 217.40$	+27mm
Number of days with snow cover	1951-2019	69	-3.64	***	$f(\text{year}) = -0.556 * (\text{year} - 1951) + 106.6$	-34 days

^a significance level: * $\alpha = 0.05$; ** $\alpha = 0.01$; *** $\alpha = 0.001$; and n.s. $\alpha > 0.1$

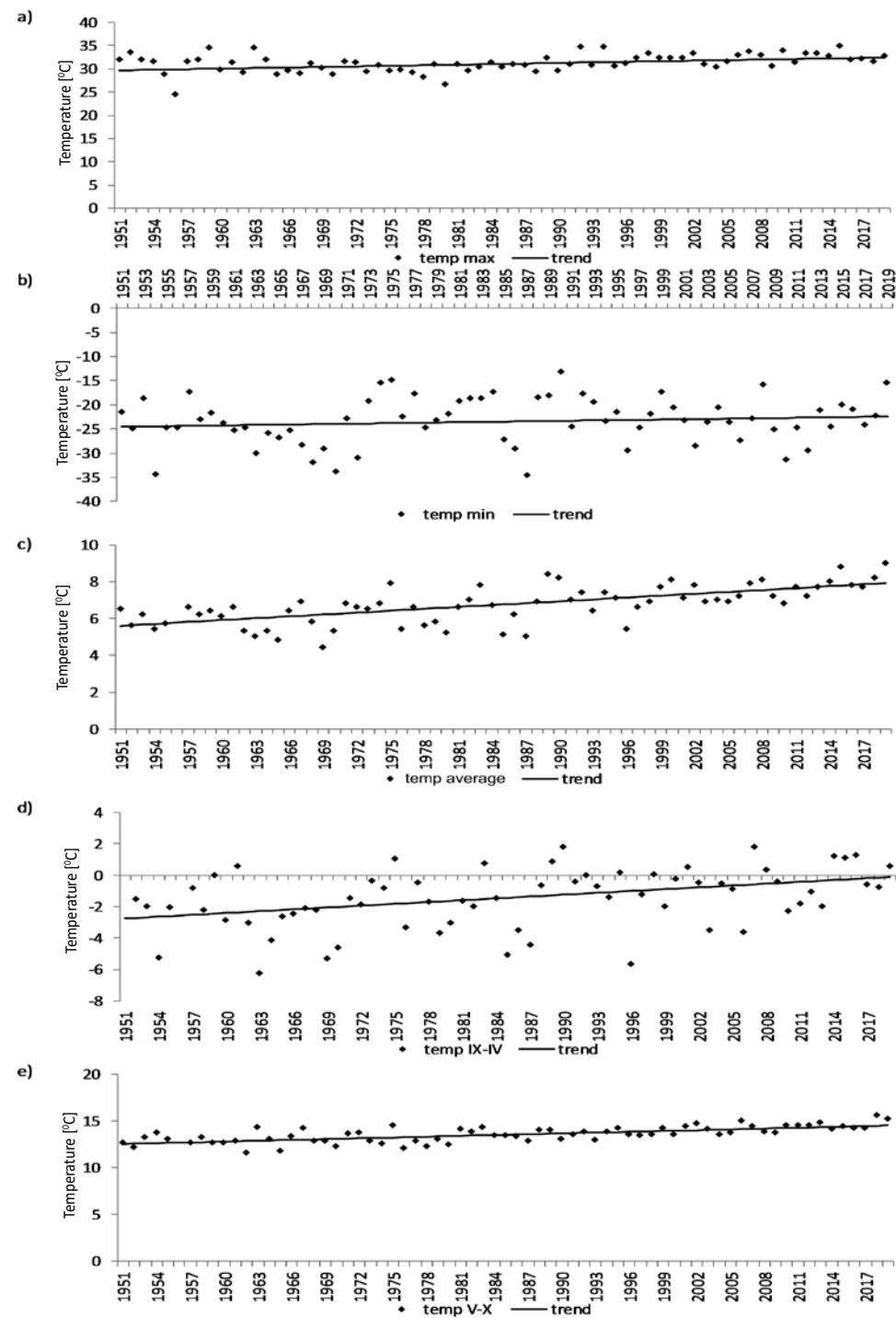

Figure 3.1. Air temperature over the period 1951-2019 in Białowieża: a) annual means, b) annual maximum, c) annual minimum, d) winter half-year mean, e) summer half-year mean (trend equations are summarized in Table 3.1)

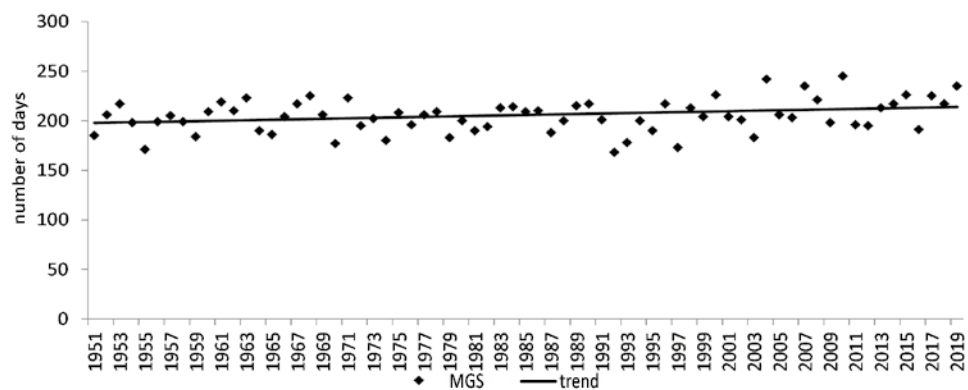

Figure 3.2. The length of the meteorological growing season in Białowieża Forest in the years 1951–2019 (The trend equation is presented in Table 3.1)

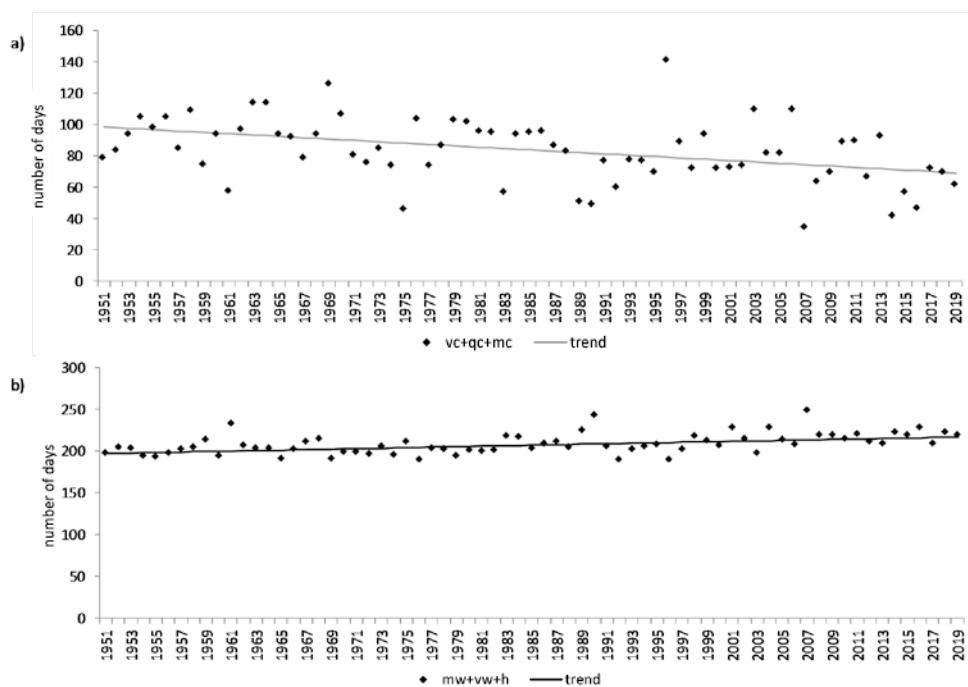

Figure 3.3. Change in the frequency of days in the years of the 1951–2019 period (a) very cold, quite cold and moderately cold, (b) moderately warm, very warm and hot (trend equations are summarized in Table 3.1)

In Białowieża, in the years between 1973 and 2019, an average of 41 days with ground frost were recorded between April and October. The highest number of days with this phenomenon was recorded in 1976, when frost occurred on 60 days, and the lowest in 1989, when frost occurred on 17 days (Fig. 3.4). It can be seen that light frosts are the most common (17 days per year on average) and that the frequency decreases as the severity of the phenomenon

increases. On average, moderate ground frosts occurred on 10 days, severe ground frosts on 8 days, and very severe ground frosts on 6 days (Fig. 3.4). Ground frosts corresponding to the different severities of the phenomenon occurred in each of the years considered, with no very severe frost recorded except in 1998. The temporal trend shows that the number of days per year with ground frost decreased by about 6 days between 1973 and 2019 (Tab. 3.1).

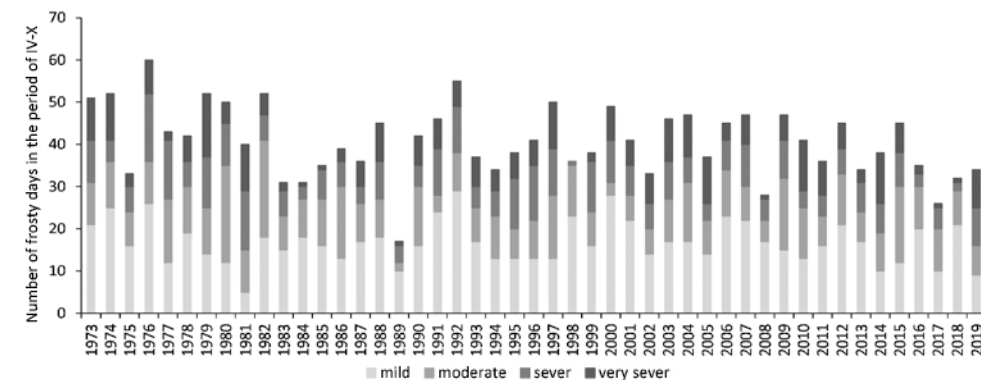

Figure 3.4. Number of days with ground frosts by the strength of occurrence

On average, 637 mm of precipitation per year was measured in Białowieża in the period 1951–2019. The lowest amount of precipitation was measured in 1953 with 425.9 mm, while the highest amount of precipitation fell in 1974 with 933.0 mm. Previous works have pointed out the periodicity of precipitation in Białowieża (Pierzgalski et al. 2002; Boczoń 2006). Based on these studies and Kaczorowska's (1962) classification used in them, the following periods can be currently distinguished:

- Period I: 1951–1966, characterized by low precipitation, with an average annual precipitation of 562.7 mm. There was 2 very dry year, 6 dry years, and 8 average years. No wet or very wet years were recorded.

- Period II: 1967–1981, dominated by years with high precipitation. The average precipitation was 733.6 mm, influenced by 4 very wet years and 5 wet years. In addition, there were 5 average years and 1 dry year.

- Period III: from 1982 to 2008, the amount of precipitation decreased, so the average amount of precipitation was 610.3 mm. Again, dry years began to dominate over wet years. 1 very dry year, 9 dry years, 15 average years and 2 wet years were recorded.

- Period IV: from 2009 to 2019, the average precipitation was 678.7 mm. The period is characterized by a high variability of years in terms of precipitation. There were 3 very wet and 2 wet years, but also 1 very dry and 2 dry years were recorded. Note that the last two years of the period were one dry and one very dry year. This could indicate the beginning of another period of lower precipitation and predominantly dry years, or subsequent years will continue the trend of high variability in annual precipitation.

The 1951–2019 multi-year trend shows a 54 mm increase in annual precipitation, but the change is not statistically significant. A similar difference of +52 mm is obtained when

comparing the average precipitation from 1891 to 1990 (Wisniewski 1953) with the average precipitation of the last 40 years of measurements: 1980–2019. Climate change projections show (Christensen et al. 2011) that precipitation in Poland will increase mainly in winter. In Białowieża, the trend of precipitation changes from 1952 to 2019 indicates such a tendency. In the winter half-year (November–April) precipitation increased by 27 mm, and in the summer half-year (May–October) by 17 mm. However, significantly less precipitation fell in the winter half-year (239.8 mm on average) than in the summer half-year (396.8 mm on average). Precipitation varies greatly from month to month, with the highest precipitation in July, averaging 83.4 mm, and in June, averaging 76.2 mm. In contrast, the lowest precipitation occurs in the first months of the year: in February 35.3 mm, in March 35.3 mm and in January 38.3 mm (Fig. 3.6). Monthly precipitation totals are characterized by high variability. October had the highest amplitude, with precipitation ranging from 2.8 mm in 2014 to 237.5 mm in 1974, and the lowest in February, with 0.6 mm in 1976 and 71.7 mm in 2002. In each month, the lowest precipitation amount did not exceed 18 mm, and the highest precipitation amount of more than 200 mm was recorded in June, July, August, and October (Fig. 3.6).

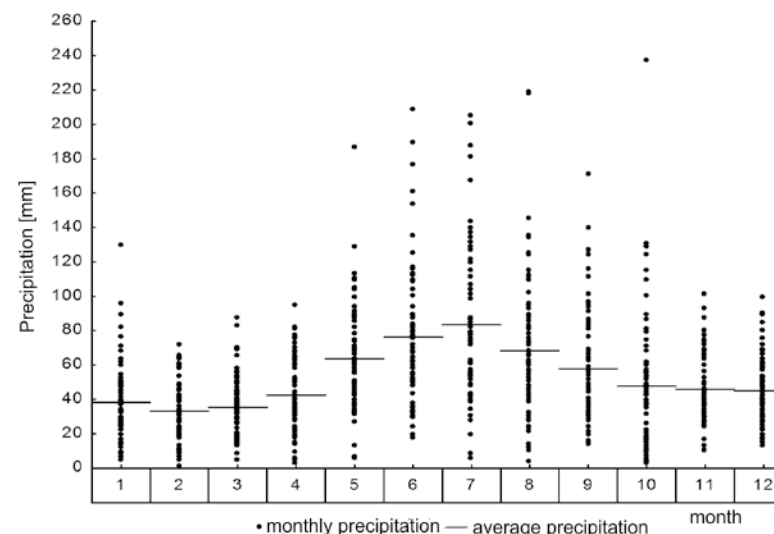

Figure 3.6. Monthly precipitation in Białowieża from 1951 to 2019

On average, snow cover in Białowieża lasts 85 days per year. The highest number of days with snow cover was recorded in 1965, when it lasted for 134 days. Still in four years: 1956, 1958, 1969, 1996, snow cover was recorded for more than 120 days. The fewest number of days with snow cover was in 2015 with 23. Also in 1975, 1989 and 1990 the number of days with snow cover was below 40 (Fig. 3.7).

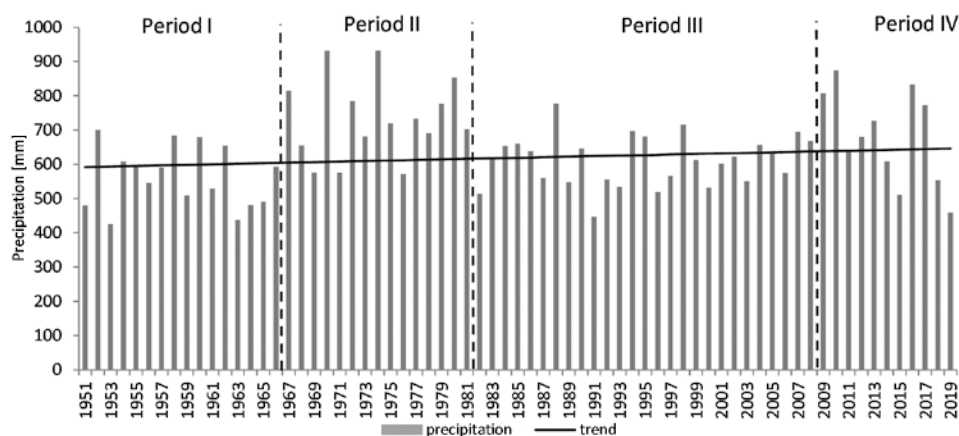
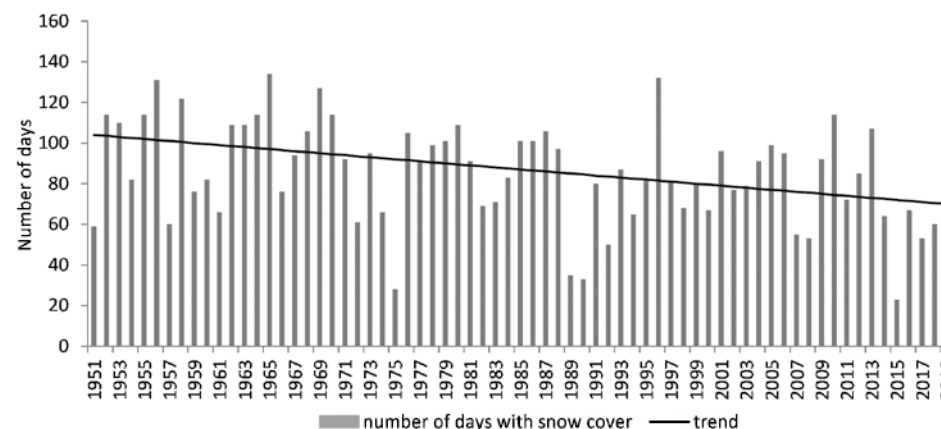

Figure 3.5. Total annual precipitation in Białowieża in the years 1951–2019 (trend equations are summarized in Table 3.1)

There are significant changes in the snow cover in Białowieża. During the considered period, the number of days with snow cover per year decreased by 34 days (Tab. 3.1). Tomczyk et al. (2021) report that in the period 1966/67–2019/20 in Białystok the number of days with snow cover decreased at a rate of 4.2 days/10 years. In Białowieża the situation is similar, here the rate of change in the period 1951–2019 was 5 days/10 years. This is probably related to climate change. It is concluded that climate warming will increase the frequency of rain in winter at the expense of snowfall (Kundzewicz et al. 2012). In addition, winter snowpack in Central Europe has declined in recent years and tends to melt much earlier (Szwed et al. 2017; Dong, Menzel 2020; Robinson 2020). During the winter of 2019/2020, snowpack was absent or patchy and largely ephemeral in much of the Polish lowlands (Tomczyk et al. 2021).



Rycina 7. Liczba dni z pokrywą śnieżną. (równanie trendu zostało zawarte w tabeli 1)

Annual precipitation amounts in Białowieża are higher compared to measurements at meteorological stations and precipitation stations in the vicinity of the Białowieża Forest. Higher values in Białowieża are determined both for the mean annual precipitation and

for the range of annual precipitation. In Białowieża, the average annual precipitation in 1951–2019 reached 637.0 mm, while at the compared meteorological stations in Hajnówka, Narwia, Klejniki and Brańsk it did not exceed 600 mm and was 587.2 mm, 589.4 mm, 574.1 mm and 563.8 mm, respectively (Fig. 3.8). In Białowieża, total annual precipitation reached values between 426 mm and 933 mm, while at measurement points outside the Białowieża Forest: in Hajnówka from 333 mm in 1959 to 803 mm in 2017, in Narew from 374 mm in 1951 to 840 mm in 2010, in Klejniki from 334 mm in 1951 to 827 mm in 1974, and in Brańsk from 344 mm in 1959 to 800 mm in 1970 (Fig. 3.8).

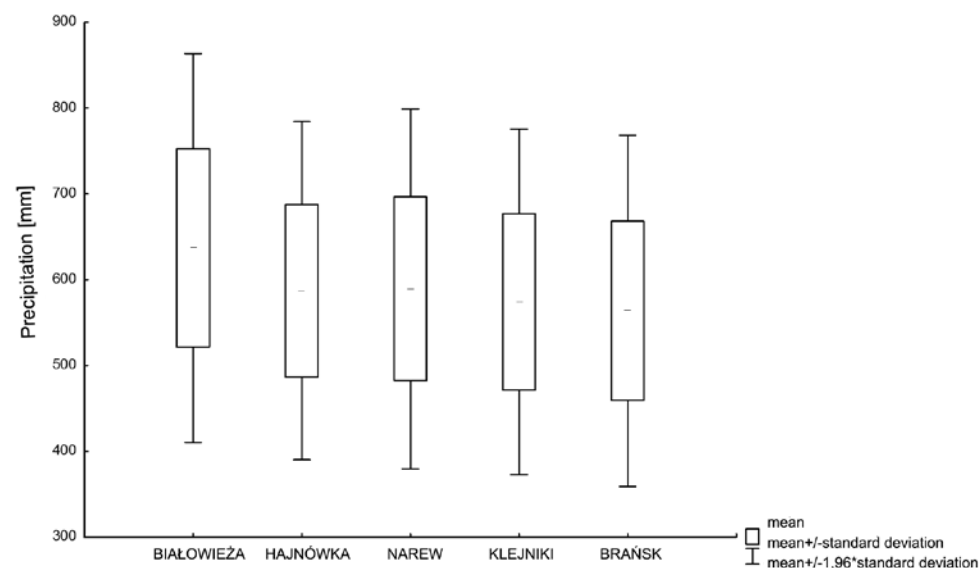

Figure 3.8. Characteristics of atmospheric precipitation measured at five points in the Białowieża Forest region during 1951–2019

Climate warming strongly influences the water balance by increasing water withdrawals for evaporation. If precipitation remains constant, this has the effect of reducing water retention, lowering groundwater levels, and decreasing river runoff. Such changes also occur in the Białowieża Forest. From 1995–2004, a decrease in the water table was observed in all habitat types: fresh, wet, and marshy; at some monitoring points, the water table dropped by more than 30 cm (Boczoń 2008). Given the steady trend of rising air temperatures after 2004, it can be assumed that the drop in groundwater levels has now increased significantly. The water deficit in river basins manifests itself in a decrease in runoff. The analysis of hydrological conditions of Polish river basins by Piniewski et al. (2018) for the period 1956–2016 at 57 monitoring points and for the period 1981–2016 at 144 monitoring points showed decreasing trends of water flow in the northern part of Poland. Boczoń et al. (2020) showed that in a small forest catchment in the Augustów Forest,

annual runoff decreased by 151.7 mm in the period 1970–2016. We are dealing with similar phenomena in the Białowieża Forest as a result of climate change. Warming in the winter months leads to earlier snowmelt and less snowfall. These processes reduce spring runoff peaks and lead to less flooding in riparian areas.

3.4. Meteorological measurements in Białowieża Forest

The variability of precipitation and other meteorological parameters in the Białowieża Forest requires measurements at at least several monitoring points. For several years, measurements have been carried out in the Polish part of the Białowieża Forest or in its vicinity by automatic meteorological stations, three of which - in Rybaki, Gruszki and Jagiellońskie Wilderness - were established as part of the ForBioSensing project (Fig. 3.9). The remaining stations perform measurements in Czerlonka within the ICP Forests network, in Wólka Terchowska, which is part of the State Forests Meteorological Stations network, in Zamosze, where the Białowieża National Park station is located, and in Topiło, where the Forest Research Institute's "extended precipitation point" operates (Fig. 3.10).



Figure 3.9. Meteorological station in Jagiellońskie Wilderness established within the framework of ForBioSensing project (photo K. Pilch)

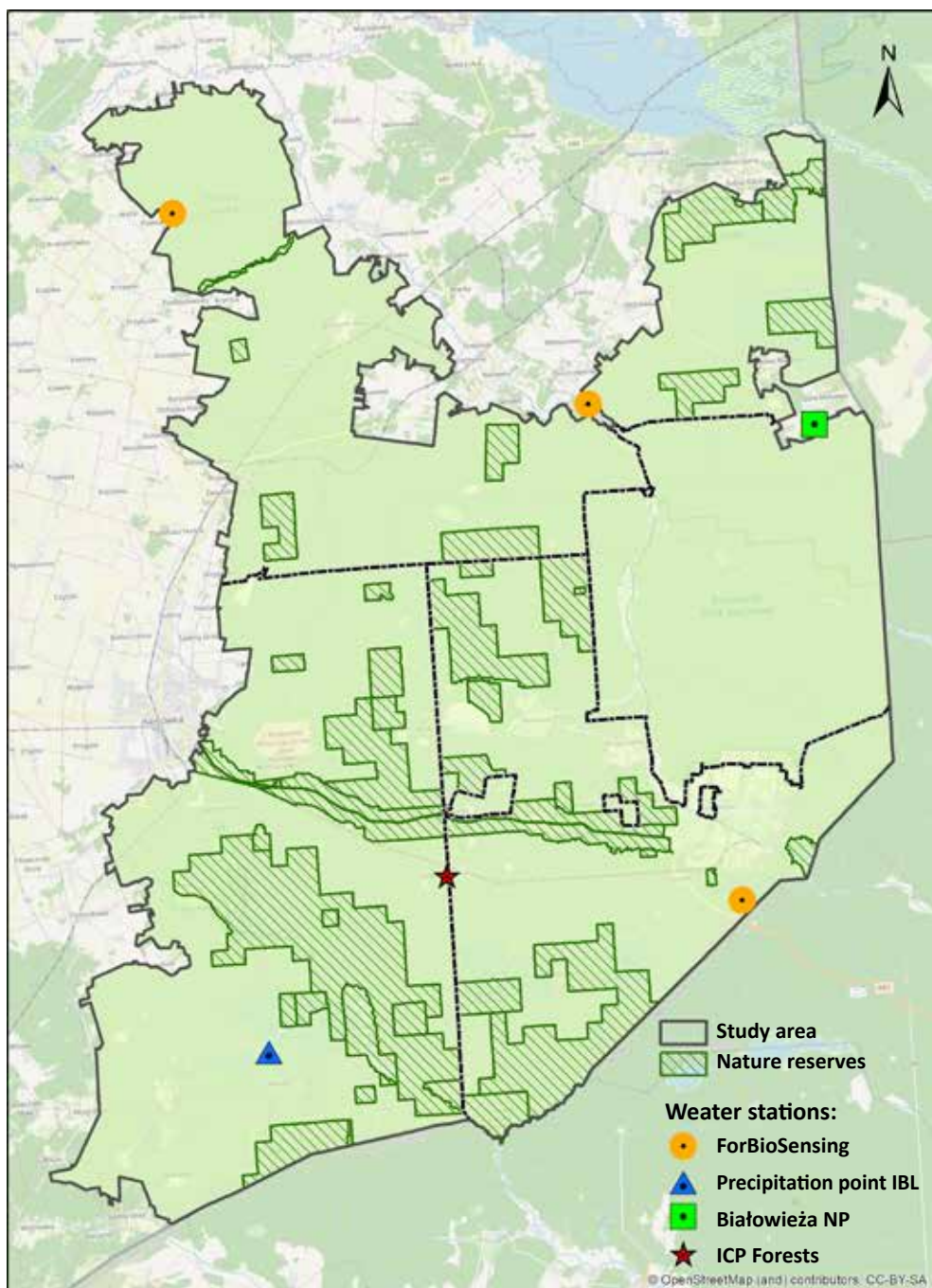

Figure 3.10. Locations of meteorological stations in the Polish part of Białowieża Forest

3.5. Conclusions

Climatic conditions in the Białowieża Forest are subject to the same changes as the warming climate in Central-Eastern Europe. The average air temperature is 6.7°C and has increased by 2.3°C between 1951 and 2019, which means that the air temperature is increasing at a rate of 0.34°C/10 years. The temperature increase also applies to the minimum temperature, maximum temperature, and average temperatures for all months of the year. Climate warming has lengthened the meteorological growing season by 16 days, mainly due to the earlier start of the growing season. The number of frost days decreased by 29 and the number of days with ground frost decreased by 9, while the number of hot days increased by 19. The analysis of the frequency of days in relation to temperature shows that the climate of the Białowieża Forest is currently similar to the climate between the Central and Western Masuria regions when compared to the climate regionalization of Woś (1996), which is based on data from 1951–1980.

The sums of annual precipitation in Białowieża are characterized by reaching higher values than at stations located near the Białowieża Forest but outside its boundaries. The average amount of precipitation in Białowieża was 637 mm. The sums of annual precipitation in Białowieża are characterized by great variability; in the years in question, distinct periods of varying precipitation can be observed. However, recent years (after 2009) in Białowieża are characterized by high variability of precipitation, with very dry and dry years alternating with wet and very wet years. The effects of climate warming mean that there are fewer and fewer days with a snow cover in the Białowieża Forest. From 1951 to 2019, the number of days with a snow cover decreased by 34.

Continued climate warming will lead to increased soil water deficits and lower groundwater levels. These changes will have a strong impact on the habitats of the Białowieża Forest.

References

- Bartoszek K., Węgrzyn A., Kaszewski B. M., Siłuch M. 2012. Porównanie wybranych metod wyznaczania dat początku i końca okresu wegetacyjnego na przykładzie Lubelszczyzny. *Przegląd Geofizyczny*, 1: 124–134.
- Boczoń A. 2006. Characteristics of thermal and pluvial conditions in the Białowieża Primeval Forest between 1950 and 2003. *Forest Research Papers*, 1: 57–72 (in Polish).
- Boczoń A., 2008. Ground water level in the northern part of Białowieża Primeval Forest after filling the “Siemianówka” water reservoir. *Forest Research Papers*, 69(4): 355–363 (in Polish).
- Boczoń A., Kowalska A., Stolarek A. 2020. The Impact of Climate Change on the HighWater Levels of a Small River in Central Europe Based on 50-Year Measurements. *Forests*, 11, 1269; <https://doi.org/10.3390/f11121269>.

- Brázdil R., Chromá K., Dobrovolný P., Tolasz R. 2009. Climate fluctuations in the Czech Republic during the period 1961–2005. *International Journal Of Climatology*, 29:223–242.
- Brohan P., Kennedy J.J., Haris I., Tett S.F.B., Jones P.D. 2006. Uncertainty estimates in regional and global observed temperature changes: a new dataset from 1850. *Journal of Geophysical Research*, 111, D12106, <https://doi.org/10.1029/2005JD006548>.
- Christensen J.H., Hewitson, B., Busuioc A., Chen A., Gao X., Held R., Jones R., Kolli R.K., Kwon W., Laprise R., Magana Rueda V., Mearns L., Menendez C., Räisänen J., Rinke A., Sarr A., Whetton P. 2007. Regional climate projections. [In:] Solomon S., Qin D., Manning M., Chen Z., Marquis M., Averyt K., Tignor M., Miller H. (Eds.), 2007: *Climate Change, The Physical Science Basis. Contribution of Working Group I to the Fourth Assessment Report of the Intergovernmental Panel on Climate Change*, University Press Cambridge, Chapter 11. Cambridge University Press Cambridge, UK and New York, NY, USA, pp. 847–940.
- Christensen O. B., Goodess C. M. Harris I., Watkiss P. 2011. European and Global Climate Change Projections: Discussion of Climate Change Model Outputs, Scenarios and Uncertainty in the EC RTD ClimateCost Project. In Watkiss, P (Editor), 2011. *The ClimateCost Project. Final Report. Volume 1: Europe*. Published by the Stockholm Environment Institute, Sweden, 2011. ISBN 978-91-86125-35-6.
- Dong C., Menzel L. 2020. Recent snow cover changes over central European low mountain ranges. *Hydrological Processes*, 34(2): 321–338. <https://doi.org/10.1002/hyp.13586>.
- Dragańska E., Rynkiewicz I., Panfil M. 2004. Częstotliwość i intensywność występowania przymrozków w Polsce Północno-Wschodniej w latach 1971–2000. *Acta Agrophysica*, 3(1): 35–41.
- Kaczorowska Z. 1962. Najsuchsze i najwilgotniejsze pory roku w Polsce w okresie 1900–1959. *Przegląd Geofizyczny*, 7(15): 3.
- Kundzewicz Z.W., Matczak P. 2012. Climate change regional review: Poland. *WIREs Climatic Change*, 3: 297–311. <https://doi.org/10.1002/wcc.175>.
- Kossakowska-Cezak U. 2003. Współczesne ocieplenie a częstość dni charakterystycznych. *Balneologia Polska*, 45(1–2): 92–100.
- Nieróbca A., Kozyra J., Mizak K., Wróblewska E. 2013. Zmiana długości okresu wegetacyjnego w Polsce. *Woda-Środowisko-Obszary Wiejskie*, 13, 2(42): 81–94.
- Pierzgalski E., Boczoń A., Tyszka J. 2002. Zmienność opadów i położenia wód gruntowych w Białowieskim Parku Narodowym. *Kosmos. Problemy Nauk Biologicznych*, 4: 415–425.
- Piniewski M., Marcinkowski P., Kundzewicz Z.W. 2018. Trend detection in river flow indices in Poland. *Acta Geophysica*, 66: 347–360.
- Robinson D.A. 2020. Northern Hemisphere continental snow cover extent [In:] Blunden, J; Arndt, D.S. *State of the Climate in 2019*. *Bulletin of the American Meteorological Society*, 101, Si–S429. <https://doi.org/10.1175/2020BAMSStateoftheClimate.1>.
- Romer E. 1949. *Regiony klimatyczne Polski*. Wybór Prac T., 453–475, Warszawa.
- Salmi T., Määttä A., Anttila P., Ruoho-Airola., Amnell T. 2002. Detecting trends of annual values of atmospheric pollutants by the Mann-Kendall test and Sen's Slope Estimates -the excel template application MAKESENS. *Publications on air quality*. No. 31, Finnish Meteorological Institute.
- Sen PK 1968. Estimates of the regression coefficient based on Kendall's tau. *Journal of the American Statistical Association*, 63: 1379–1389.
- Solomon S., Qin D., Manning M., Marquis M., Averyt K., Tignor M.M.B., LeRoy Miller H., Chen Z. 2007. *Climate Change: The Physical Science Basis*. Cambridge University Press: Cambridge, New York, Melbourne, Madrid, Cape Town, Singapore, Sao Paulo, Delhi. Szwed, M.; Pińskwar, I.; Kundzewicz, Z.W.; Graczyk, D.; Mezghani, A. 2017. Changes of snow cover in Poland. *Acta Geophysica*, 65: 65–76. <https://doi.org/10.1007/s11600-017-0007-z>.
- Tomczyk A., 2015. Przymrozki wiosenne i jesienne oraz okres bezprzymrozkowy na Nizinie Wielkopolskiej w latach 1981–2010. [In:] *Współczesne problemy i kierunki badawcze w geografii*. T. 3, Instytut Geografii i Gospodarki Przestrzennej UJ, Kraków: 245–256.
- Tomczyk A.M., Bednorz E., Szyga-Pluta K. 2021. Changes in Air Temperature and Snow Cover in Winter in Poland. *Atmosphere*, 12, 68. <https://doi.org/10.3390/atmos12010068>.
- Tomczyk A.M., Szyga-Pluta K. 2016. Okres wegetacyjny w Polsce w latach 1971-2010. Growing seasons in Poland in the period 1971–2010. *Przegląd Geograficzny*, 88(1): 75–86.
- Wiszniewski W. 1953. *Atlas opadów atmosferycznych w Polsce 1891–1930*. Wydawnictwa Komunikacyjne, Warszawa.
- Woś A. 1996. *Zarys klimatu Polski*. Wydawnictwo Naukowe UAM Poznań.
- Woś A. 2010. *Klimat Polski w drugiej połowie XX wieku*, Wydawnictwo Naukowe UAM, Poznań.

II. Status and dynamics of the Białowieża Forest stands - analysis based on field data

4. Wood resources of the Białowieża Forest in 2015-2019 - status and dynamics

Stanisław Miścicki¹, Łukasz Kuberski², Rafał Paluch²,
Kamil Pilch², Krzysztof Stereńczak³

¹ Warsaw University of Life Sciences, Department of Forest Management,
Dendrometry and Forest Economics, Nowoursynowska 159, 02-776 Warsaw

² Forest Research Institute, Department of Natural Forests, 6 Park Dyrekcyjny St., 17-230 Białowieża

³ Forest Research Institute, Department of Geomatics, Sękocin Stary 3 Braci Leśnej St., 05-090 Raszyn
stanislaw_miscicki@sggw.edu.pl;
{l.kuberski, r.paluch, k.pilch, k.sterenczak}@ibles.waw.pl

Abstrakt

The natural resources of the Białowieża Forest are rich and relatively well preserved. Research on the state of wood resources of the Białowieża Forest has been sparse and often referred to its fragments - more to the Strict Reserve, less often to the stands in the managed part of the Forest. Determination of the state of wood resources of the whole (Polish) part of the Białowieża Forest became possible after a unified network of permanent sample plots was established within the ForBioSensing project.

The study material consisted of the results of measurements taken three times on permanent concentric sample plots in 2015, 2017, and 2019. They were arranged according to a 1300 m × 1300 m square grid. Because there were relatively few such sample plots in the Strict Reserve (due to the relatively small size of this „interpretation unit”- used to present and interpret results), we also used 160 sample plots distributed on a grid with average dimensions of 267 m × 1067 m, also measured in 2015, 2017, and 2019. Concentric sample plots of equal size were measured at each measurement time. The location of each tree, including those from the regeneration layer, was determined relative to the centre of the sample plot. The biometric parameters of all trees with diameter at breast height at least 7 cm located within the sample plots were also measured.

In 2015, the average volume of Białowieża Forest stands was quite big - it amounted to almost 400 m³ ha⁻¹. In 2019, this value decreased to about 360 m³ ha⁻¹. The current volume increment averaged about 8,4 m³ ha⁻¹ year⁻¹. The volume net change for 2015–2019 was

-41,1±13,7 m³ ha⁻¹ *i.e.* 10,3±3,4 m³ ha⁻¹ year⁻¹. In 2015, Norway spruce had the largest volume share (32%), but in 2019, Scots pine had the largest share (23%). In 2019, spruce volume was 58% of 2015 volume, and it was one of the two species (along with ash) whose volume and proportion decreased so significantly during this period. Hornbeam was the most numerous in the low and high saplings layer. A new situation was the dominance of maple in the seedlings layer. In 2015-2019, the volume of dead trees in the Białowieża Forest amounted to 4.173 million m³, of which 2.750 million m³ (66%) were spruce.

Keywords: multi-temporal analyses, ingrowth, interpretation unit, young generation, growth, species composition, loss, parent layer, change

4.1. Introduction

4.1.1. Historical aspect of studying the status of wood resources of Białowieża Forest

A number of historical events influenced the fact that at the end of the period of intensive forest transformation in Central Europe (conventionally: before the outbreak of World War I) the natural resources of Białowieża Forest were relatively well preserved. In spite of some transformation, often considerable, of the fragments of this vast forest area as a result of intensive and often wasteful manage during World War I and common exploitation of Polish forests after the war, in order to gain funds for the reconstruction of the country, already in 1921 Białowieża National Park was created (although formally under a different name until 1932), as well as several nature reserves. Białowieża Forest itself, especially Białowieża National Park, has become a place and object of many researches. However, there have been few studies that have looked at the status of Białowieża Forest's wood resources. The term “wood resources” can be understood here as a set of features that represent (often in relation to the area of the entire forest complex or to the area unit): the volume of trees, their number, the share of species, their damage, their age structure, the structure of tree dimensions (most often diameters), the area coverage by tree crowns, stand structure, the amount of young trees (regeneration), their quality and damage, volume increment, the intensity of tree dying, the supply rate of the canopy layer by trees growing out of the regeneration layer, changes in the quantitative state of many of these features. Some of the features on this list (and an incomplete one at that) have been of interest to researchers since the beginning of so-called modern forestry – even from the early 19th century and before. Many of these became of interest after approx. 1950 (Köhl *et al.* 2006). More features continue to add to this list, e.g. those related to dead wood resources.

Historically, the set of features that characterise the state of wood resources has been modest. This was not only due to less need for knowledge about the forest. A significant limitation was the lack of appropriate inventory methods over extensive forested areas. Regularly collected such data which were used in plan preparation for managed forests. For this reason, historical data characterising the forest are thematically sparse, and their reliability (due to the data inventory methods adopted rather than the quality of the work performed) may be questionable. Apart from managed forests, data were also collected in forests of national parks and nature reserves. Initially according to the so-called author's concepts specific to

a given object (Niedziałkowski 1949), and later according to a compulsory instruction (Instrukcja... 1962).

The establishment of the Białowieża Forest Park influenced the fact that for decades it was impossible to obtain data that would present the state of the wood resources of the entire Białowieża Forest at one time. The 1945 division of the naturally homogeneous forest area into parts belonging to two countries made it even more difficult to obtain such data. Since then, the characteristics of Białowieża Forest stands in most cases are made separately for the Polish part and separately for the Belarusian (formerly Soviet).

4.1.2. Determination of the state of wood resources in the managed part of Białowieża Forest

Forest management plans are the source of data about Białowieża Forest wood resources. For the interwar period, synthetic data on managed forests (state forest districts) were presented by Więcko (1984), using a provisional plan from 1920 and a definitive one from 1931. More detailed data for this period will probably be unobtainable. In many cases, forest management plans, especially those that were up to date, were destroyed at the beginning of World War II by the Polish forestry administration to make management (practically: excessive logging) more difficult for the occupying forces. Destroying the plans was easy because they were usually prepared in only 2-3 copies. After World War II, in the years 1948–1949, in the Polish part of Białowieża Forest the so-called provisional forest management (for the managed part) was carried out. Some of the most important data from this plan were presented by Więcko (1984). In 1958 plans were elaborated according to the so-called definitive forest management planning. The work was carried out with great care. Their results can be found in archival resources, and a synthesis was presented by Czerwiński (1968). In 1968, data on wood resources of state forest districts in the Białowieża Forest were collected in a similar manner as in 1958. Complete enumeration (determination of tree species and diameter at breast height DBH measurement of all trees) was performed in mature and over-mature stands, and when their area was too large, assessment on field plots (generally 1 ha in size) subjectively placed at "representative" location were used. The same type of sample plots, except that they were smaller (0.25-0.75 ha), were used in pre-mature stands (generally older than 40 years). In the youngest stands, their features were visually assessed. In 1979 the wood resources inventory for the preparation of the forest management plan were conducted for the first time by applying the representative method with the use of randomly distributed Bitterlich samples. Forest districts located in Białowieża Forest were considered as objects of implementation of this method in forest management planning. The inventory of wood resources during the preparation of subsequent forest management plans has already been performed with the use of the representative method, and in 2011, for the first time, circular sample plots were used.

4.1.3. Determination of the state of the wood resources of the Białowieża National Park

Determination of the state of wood resources in Białowieża National Park was performed at different times than in the forest districts of Białowieża Forest. The first works on delineating and measuring the boundaries of forest stands in Białowieża National Park and assessment of their structure were carried out in the years 1936–1939 on the initiative of Jozef Kostyrko – head of the Division of Reserves and National Parks Research in the State Forest Research Institute in Warsaw. These works were directed by Prof. Waław Niedziałkowski. Stand characteristics were evaluated on a 4 m wide strip along the longer diagonal of the stand contour. By the time World War II broke out in 1939, about 80% of the studies had been completed. The materials deposited in the building of the Ministry of Forestry in Warsaw were – without military reason – burned by German troops during the Warsaw Uprising in 1944. Only map prints with boundaries and information on the area of forest stands have survived.

In 1947, using the preserved map, new works on recognition of the forest condition of Białowieża National Park were started. Stand descriptions, including relevé according to the Braun-Blanquet method, and soil surveys were performed. In stands with an area of more than 1 ha (since 1948 more than 1.5 ha), sample plots with a radius of 25.23 m (2000 m²) were established, where DBH, and height of trees were measured and their age was assessed. In smaller stands, 4-metre-wide sample strips along the longer diagonal were used. Until 1949 (until his death) the work was directed by Professor Niedziałkowski. Field work was completed under the direction of later Professor (then master of science) Ryszard Zaręba in 1953 and 1958 (in the case of 1958, it was a strip of forest compartments along the border with the USSR that was inaccessible until 1956). Due to funding shortfalls, many of the final studies were not completed – including the compilation of stand descriptions and the calculation of quantitative stand characteristics. These data have not been elaborated to date (2021).

The first results concerning stands of the whole Białowieża National Park were obtained only after measurements made in 1989–1990 by the Bureau of Forest Management and Geodesy in Białystok (Michalczuk 2001). Previously (since 1985), soils were surveyed and forest habitats were assessed. Boundaries of stands were established, their structure was described and basic features were measured (volume, average DBH and height of particular tree species), age of trees was estimated (on the basis of relation between DBH and age, measured earlier on dead trees). The volume of individual living trees was calculated using the same method as in the forest management inventory at that time (Instrukcja... 1980). In each stand, depending on its area and degree of complexity, 3-20 Bitterlich samples were measured with a basal area factor $k = 4$, but without callipering of the trees included in the sample. There were a total of 5460 samples. For a tree species whose volume share in a given stand was less than 5%, it was "swapped" to the most similar species or to the main species during the inventory. Thus, the proportion of sparse species was underestimated to an unknown degree. The growing stock volume (merchantable timber volume) of all stands was estimated with high accuracy – the error was $\pm 0.70\%$ (at significance level $p=0.05$). However, the scope of this inventory was modest and included estimation of volume by species, age classes (not very useful in natural forest) and stand area by dominant tree species and forest habitats (Michalczuk 2001).

In 1995, in the area of Białowieża National Park, data were collected on 460 temporary sample plots distributed in a 100 m × 1000 m grid, the shorter side of which was oriented according to the azimuth 330° (Krasuska, Miścicki 2002). This inventory was the first time that data were collected to determine, using a representative method, the status of the regeneration (young tree) layer. In 2005, using the same distribution scheme, data were again collected in 460 temporary sample plots. This allowed to assess some of the changes occurring in the stands of Białowieża National Park in the periods 1990–1995–2005 (Miścicki 2012), as well as to determine the interdependencies between tree species of the regeneration layer and species of the canopy layer (Gazda, Miścicki 2018).

Detailed assessments of stand dynamics in the so-called Strict Reserve of Białowieża National Park (*i.e.*, within the former boundaries of the national park) in the period 2000–2004 were made on the basis of data collected on 160 permanent sample plots (Miścicki 2012). Some of the 384 measurement points set by Białowieża National Park staff in 1998–1999 were used as sample plot centres, these being set by the quoted author in the case of three areas with no measurement points. All sample plot centres were located at a distance of 71 metres and according to an azimuth of 45° from a branch post (or an auxiliary post placed at the midpoint of the forest branch side). They formed a grid with average dimensions of 267 m × 1067 m, with the longer side oriented approximately according to the 0° azimuth. The same sample plots were used to assess changes in the stands of the Strict Reserve of Białowieża National Park in the period 2000–2015 (Miścicki 2016). A complete network, counting 384 permanent sample plots in the area of the so-called Strict Reserve of Białowieża National Park (*i.e.*, within the former boundaries of the national park) in 2009, was used by Brzeziecki *et al.* (2010) for a study on stand dynamics, including regeneration layer dynamics. This study also included a part of Białowieża National Park added in 1996, which included a separate network of 206 sample plots. The differences between the stands of the Strict Reserve and the forests of the new part of Białowieża National Park were taken into account, giving many results separately for each of these units.

A special place in the assessment of the state and dynamics of the wood resources of Białowieża National Park is occupied by the research conducted with the use of permanent observation (research) plots with identification of trees (with DBH $d \geq 5$ cm). They were established in 1936 by Prof. Tadeusz Włoczewski, an employee of the Forest Research Institute, re-measured around 1957 and since then regularly inventoried at an interval of about 10 years (Bernadzki *et al.* 1998a, b). There are five of them, they have the shape of an elongated rectangle, and their total area is 15.44 ha. The intention was to establish them in such a way that they would represent all the diversity of the stands of the so-called Strict Reserve of the Białowieża National Park, and at the same time be situated in a forest as little degraded by human activity as possible. Although there is a problem with adequacy of representation of the Białowieża National Park stands by these plots (*e.g.*, lack alder swamp forest habitat and – apart from ash alder forest – other swamp habitats), the results of measurements carried out on these plots constitute unique material illustrating the changes in the natural forest over the period of more than 80 years (*e.g.* Brzeziecki *et al.* 2016, 2020).

4.1.4. Determination of the state of the wood resources simultaneously in the whole Białowieża Forest

The first determination of the state of the wood resources in both the managed and the protected part of Białowieża Forest was possible after performing inventory on permanent sample plots established in the years 2005–2009 within the framework of the National Forest Inventory of the State of Forests (WISL). These measurements repeated every five years (2010–2014, 2015–2019 periods) allowed assessment of the dynamics of wood resources. However, the use of these data was limited. This was due to the general purpose of the WISL data for assessing large administrative units such as all forests of individual provinces, natural forest regions, or the entire country. Although in the area of the Polish part of Białowieża Forest there were 184 sample plots grouped in 41 tracts, each of which contained five sample plots (or less when the centre of the sample plot fell outside the forested area), their number was only sufficient for the general characterization of Białowieża Forest stands. These sample plots were too few to separately assess the status of wood resources of, for example, Białowieża National Park. Moreover, the size of the sample plot for determining the state of the young generation of trees was too small (20 m²) – especially in the case of the so-called high saplings (trees with a DBH of 4–6.9 cm) (Michalak *et al.* 2004).

Determination of wood resources in the whole (Polish part) of Białowieża Forest became possible after establishing a uniform network of permanent sample plots. It was projected and performed in 2015 within the LIFE+ project ForBioSensing PL “Comprehensive monitoring of the dynamics of Białowieża Forest stands using remote sensing data” by employees of the Forest Research Institute in Sękocin Stary and Białowieża in cooperation with Stanisław Miścicki, an employee of the Faculty of Forestry of the Warsaw University of Life Sciences. The centres of the sample plots, which numbered 355, were arranged according to a square grid pattern of 1300 m × 1300 m. The grid was rotated so that one of the sides was oriented according to an azimuth of 330°. This was to avoid linking grid spacing to, for example, forest compartment arrangement or with repeated silviculture or forest management treatments. Inventories were repeated in 2017 and 2019 (see Map 1).

In 2016, the data for the above grid was made available to the Directorate General of State Forests. This grid was compacted four times (side was 650 m × 650 m), resulting in 1373 sample plots. These sample plots were measured in 2016, 2017 and 2018 for the project “Assessment of the status of biodiversity in Białowieża Forest based on selected natural and cultural elements”.

4.1.5. Purpose of the work

Data collection on permanent sample plots as part of the implementation of the ForBioSensing project scheduled for years: 2015, 2017, and 2019, so as to understand the short-term dynamics of the wood resources of Białowieża Forest, and also to determine whether different parts of this forest, different due to management and conservation history, differ in the structure and dynamics of wood resources.

4.2. Materials and Methods

4.2.1. Interpretation units

The total area of Białowieża Forest (BF) stands that were included in the study was 56 003 ha. The three interpretation units, which are distinct parts, were:

- managed stands (hereinafter referred to as “Managed Forest” and sometimes designated as “MF”) covering an area of 35,241 ha, *i.e.*, 62.9% of Białowieża Forest,
- stands in nature reserves established in different years with the so-called new part of Białowieża National Park attached (further referred to as “Nature Reserve” and sometimes marked as “NR”) covering 16,138 ha, *i.e.*, 28.8%,
- stands in the so-called Strict Reserve of Białowieża National Park, *i.e.*, within the original boundaries of Białowieża National Park (further referred to as “Strict Reserve” and sometimes as “SR”) covering 4 623 ha, *i.e.*, 8.3%.

4.2.2. Research material

The research material consisted of data taken three times in permanent sample plots in 2015, 2017, and 2019. Sample plots distributed according to a 1300 m × 1300 m square grid scheme were used. Since there were relatively few such sample plots in the Strict Reserve (due to the relatively small area of this interpretation unit), 160 sample plots distributed in a grid with average dimensions of 267 m × 1067 m were also used. The number of sample plots in interpretation units equaled: MF – 204, NR – 91, SR – 182, total 477. The first campaign of data collection in permanent sample plots distributed across Białowieża Forest was in 2015, when a significant number of Norway spruce trees were dying as a result of bark beetle feeding.

Concentric sample plots of the same size were measured on all occasions. Each consisted of four circles with the following areas: 5.31 m² (within which all trees at least 2 years old were measured – regardless of size), 20 m² (measurement of trees with height $h \geq 0.3$ m),

50 m² (measurement of trees with $DBH \geq 2$ cm), 500 m² (measurement of trees $DBH \geq 7.0$ cm). The location of individual trees, including those from the regeneration layer, relative to the centre of the sample plot was determined. This used the magnetic azimuth of the left edge of the trees and the distance to the growing site. This allowed them to be identified during subsequent measurements. In this way, size changes and overall status (surviving, loss, ingrowth) were determined. The species were identified, and DBH and height of each tree included in the sample were measured.

Since 2017, the measurement of sample plots has been conducted digitally using a mobile application that is an element of the information system developed within the ForBioSensing project by Bartłomiej Kraszewski with substantive support from Łukasz Kuberski. The system (Fig. 4.1) consists of four parts:

- FBS_Assessment application for entering measurement data on mobile devices,
- FBS_Integrator application responsible for integrating measurements from many mobile devices,
- local database (Local DB) installed on mobile devices, where measurement data were stored,
- a central database (Central DB) installed on a desktop device that integrates measurements from many mobile devices.

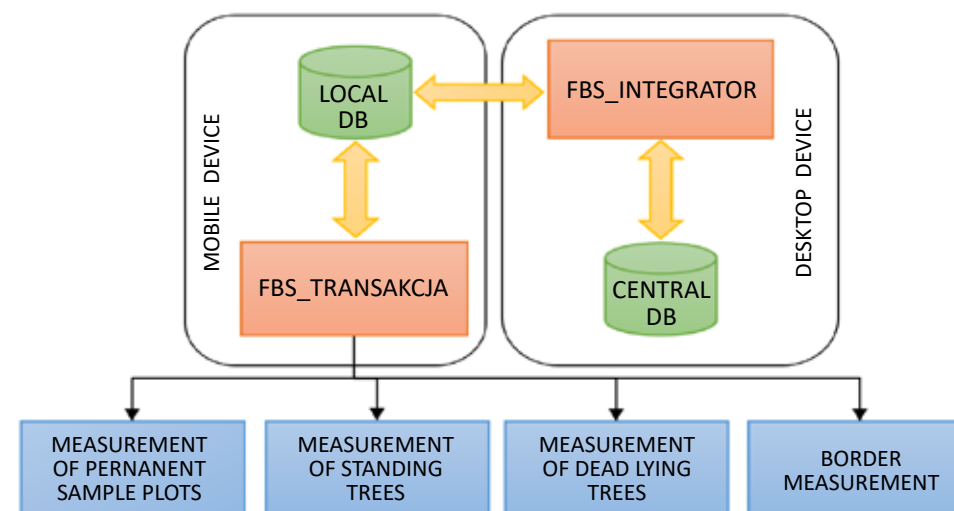

Figure 4.1. Overall schematic of the project's taxonomy information system

The FBS_Surveying application was installed on mobile devices used in the field (Fig. 4.2). A PostgreSQL database was integrated with the application, which stored measurements from 2015 and new data acquired since 2017.



Figure 4.2. FBS_Surveying application on a mobile device during fieldwork (photo K. Pilch)

The use of data from 2015 accelerated field work in subsequent inventory years, which mostly consisted of updating previous tree measurements. The FBS_Surveying application consists of four basic tabs (Fig. 4.3):

- tab for describing characteristics of the stand around the sample plot,
- tab for data on standing trees,
- tab for data on dead lying trees,
- tab for data on a stand boundary (if exists).

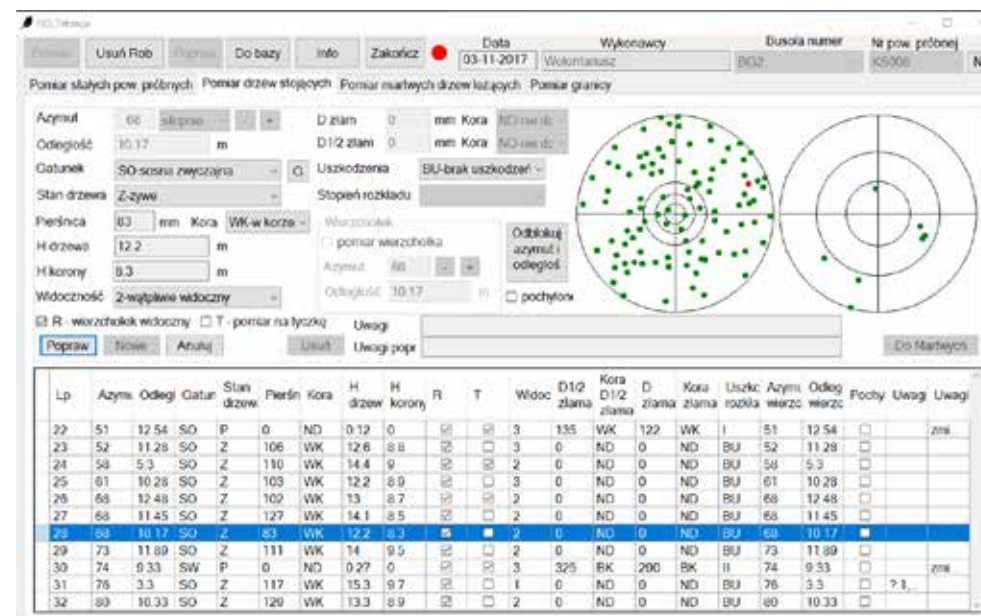

Figure 4.3. Example window of the FBS_Surveying application

The main features of FBS_Surveying were: full integration with the database, backup during the measurement (in case of power failure or interruption of the measurement) and after its completion, graphical representation of the measurements allowing for better orientation on the sample plot in the field, control of the correctness of the entered data and minimising the use of the keyboard during the measurement by adding selectable menus.

4.2.3. Data preparation for calculations

The volume of sampled trees was calculated using formulas currently used in Polish forest management (Bruchwald *et al.* 2000). The lower threshold for measuring the DBH and calculating growing stock volume (to be included in the canopy layer) was 7.0 cm. The volume of trees exceeding (as a result of growth) DBH threshold of 7.0 cm (ingrowth in a given period), as well as the volume increment of these trees, were calculated according to the rules adopted by Miścicki and Nowicka (2007). The volume of live trees with broken tops was reduced accordingly. When a stem fracture site was decreasing during a given period, the loss volume of such a tree was referred to as “partial loss”. To determine the amount of regeneration, the sum of tree heights per square-unit was mainly used, and to a lesser extent density of trees (number of trees per square-unit).

4.2.4. Data analyses

Calculations of mean values of the so-called static and dynamic features and structural features were performed. Calculations of so-called static features (*e.g.*, merchantable timber volume) were carried out for three dates: 2015, 2017, and 2019. For dynamic features (*e.g.*, current volume increment), calculations were performed for two periods: 2015–2017 and 2017–2019. In some cases, especially when the value of a given feature changed a little, state differences were determined for the 2015 and 2019 dates, and for dynamic features, its value was determined for the entire 2015–2019 period. The calculations for structural characteristics referred to the distribution of the number of trees in DBH classes and the tree species composition of stands or particular stand layers (canopy trees, seedlings, low and high saplings).

Calculations of mean values of static or dynamic features were performed for each interpretation unit. For the stands of the whole Polish part of Białowieża Forest, they were estimated as for the stratified sampling. In this situation, the mean value was:

$$\bar{x}_{BF} = \bar{x}_{MF} \cdot p_{MF} + \bar{x}_{NR} \cdot p_{NR} + \bar{x}_{SR} \cdot p_{SR}$$

where:

\bar{x}_{MF} , \bar{x}_{NR} , \bar{x}_{SR} – mean values for individual interpretation units,

p_{MF} , p_{NR} , p_{SR} – share of area of individual interpretation units,

the mean error was defined as:

$$S_{BF} = \sqrt{S_{MF}^2 \cdot p_{MF}^2 + S_{NR}^2 \cdot p_{NR}^2 + S_{SR}^2 \cdot p_{SR}^2}$$

where:

S_{MF}^2 , S_{NR}^2 , S_{SR}^2 – mean square error for individual interpretation units,

p_{MF} , p_{NR} , p_{SR} – share of area of individual interpretation units.

The empirical distribution of most features (quantities per sample plot related to 1 ha area) had a positively skewed distribution. In this case, a root-mean-square transformation of the data was performed before proceeding to statistical analyses. Repeated measures ANOVA was used to compare mean values obtained from permanent sample plots. Post-hoc multiple comparisons of mean values (of the state of a feature at particular dates or periods and between interpretation units) were conducted using Tukey's HSD (honest significant difference) test.

The similarity of the structure of the number of trees in the size classes was assessed using the test proposed by Zingg and Duc (1998):

$$res = \frac{\sum_{i=1}^k (\ln z_1 - \ln z_2)^2}{k - 1}$$

where:

z_1 , z_2 – number of trees in a size class i in two compared units,

k – number of size classes.

Because of the decreasing number of trees in successively thicker DBH classes, classes with unequal widths (which were multiples of 4 cm), which were getting larger with dimensions were used. Following the quoted authors, it was assumed that the distributions are similar when the *res* value is 0.5 or less, and partially similar when the value is between 0.5 and 1.0.

The similarity of tree species composition between a pair of interpretation units or terms (within a particular unit) was determined using Morisita's *M* index in Horn modification (1966). Its value was calculated using the formula:

$$M = \frac{2 \sum_{i=1}^k x_i \cdot y_i}{(\sum_{i=1}^k x_i^2)(\sum_{i=1}^k y_i^2)}$$

where:

x_i – share of i th species in unit X,

y_i – share of i th species in unit Y,

k – number of species.

4.3. Results

4.3.1. Growing stock volume

In 2015, the average growing stock volume (GSV) of stands of Białowieża Forest was quite high – it was nearly 400 m³ ha⁻¹ (Fig. 4.4, Tab. 4.1). However, it declined significantly in subsequent inventory dates. Considering the three dates, GSV differed significantly only between the stands of SR and MF ($p=0.005$). In each interpretation unit, the trend of change was the same as in Białowieża Forest as a whole, but only GSV of stands of MF decreased significantly from 2015 to 2019 ($p<0.001$).

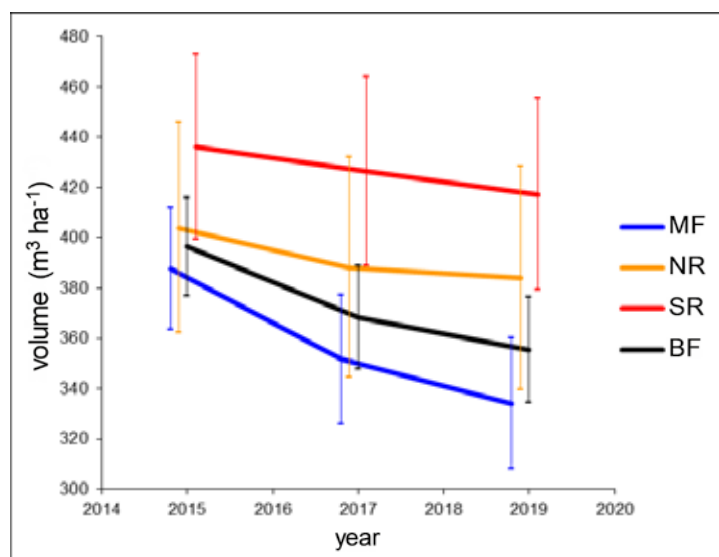

Figure 4.4. Average growing stock volume in interpretation units of Białowieża Forest in 2015, 2017, and 2019. Similarity and differences in mean values (at $p=0.05$): SR \neq MF; BF15 \neq BF17 \neq BF19; MF15 \neq MF17, MF15 \neq MF19; MF17 \neq SR17, MF19 \neq SR19; other differences – not significant. MF – Managed Forest, NR – Nature Reserve, SR – Strict Reserve, BF – Białowieża Forest (Polish part, all interpretation units in total)

Table 4.1. Growing stock volume and tree density in interpretation units of Białowieża Forest in 2015, 2017, and 2019; trees with DBH \geq 7.0 cm; standard error SE at $p=0.05$.

Feature Interpretation unit	Year					
	2015		2017		2019	
	mean	SE	mean	SE	mean	SE
Volume (m³ ha⁻¹)						
MF Managed Forest	388	24	352	26	334	26
NR Nature Reserve	404	42	388	44	384	44
SR Strict Reserve	436	37	426	37	417	38
Białowieża Forest (total)	396	20	368	21	355	21
Tree density (ind. ha⁻¹)						
MF Managed Forest	692	50	648	51	614	52
NR Nature Reserve	707	82	667	77	638	73
SR Strict Reserve	589	35	570	35	547	34
Białowieża Forest (total)	688	39	647	39	615	38

4.3.2. Tree density of the canopy layer

Considering the three measurement dates, tree density of the canopy layer (trees with DBH \geq 7.0 cm) was significantly higher in SR stands than in MF stands ($p=0.036$) (Fig. 4.5). Because GSV was the highest in SR and the lowest in MF, the average tree volume was the highest in SR stands and lowest in MF stands. In subsequent inventory dates, tree density decreased significantly throughout Białowieża Forest ($p<0.001$). The trend of change was the same across interpretation units. In each, the decrease in tree density between opposite measurement dates was significant ($p<0.001$ for all units).

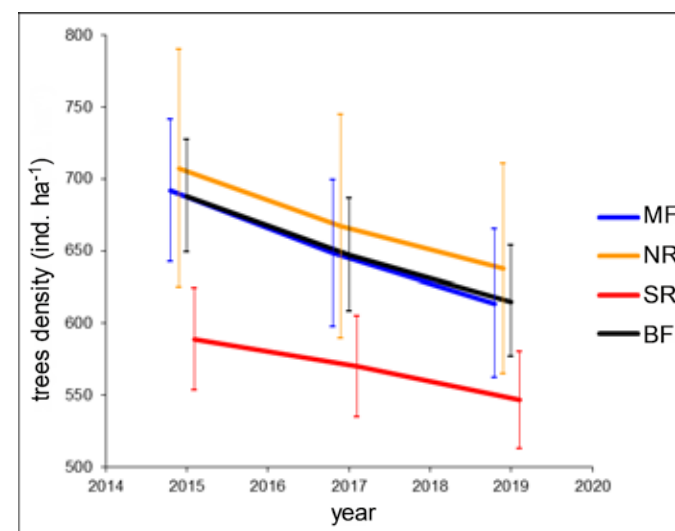

Figure 4.5. Average density of trees in the canopy layer in interpretation units of Białowieża Forest stands in 2015, 2017, and 2019. Similarity and differences in mean values (at $p=0.05$): SR \neq MF; BF15 \neq BF17 \neq BF19; MF15 \neq MF17 \neq MF19; NR15 \neq NR17, NR15 \neq NR19; SR15 \neq SR19, SR17 \neq SR19; other differences – not significant. MF – Managed Forest, NR – Nature Reserve, SR – Strict Reserve, BF – Białowieża Forest (Polish part, all interpretation units in total)

4.3.3. Current volume increment

The current volume increment, which averaged about 8.4 m³ ha⁻¹ year⁻¹ in Białowieża Forest, differed only slightly between the two two-year periods (Fig. 4.6, Tab. 4.2). There were also insignificant differences in volume increment between the interpretation units. The volume increment estimated for the entire four-year period was slightly smaller than that calculated as the sum of the two two-year periods. For the whole Białowieża Forest it amounted to 8.10 \pm 0.41 m³ ha⁻¹ year⁻¹. This difference was due to excluding the volume increment of trees that died in the period 2017–2019.

Table 4.2. Current volume increment, ingrowth volume, loss volume and volume net change in interpretation units of Białowieża Forest in the 2015–2017, 2017–2019 and 2015–2019 periods; trees with DBH≥7,0 cm; standard error SE at $p=0.05$

Feature Interpretation unit	Period					
	2015-2017		2017-2019		2015-2019	
	mean	SE	mean	SE	mean	SE
Current volume increment (m ³ ha ⁻¹ year ⁻¹)						
MF Managed Forest	8.46	0.57	8.42	0.58	8.10*)	0.55
NR Nature Reserve	8.06	0.79	8.82	0.85	8.26	0.76
SR Strict Reserve	8.03	0.55	7.55	0.57	7.61	0.51
Białowieża Forest (to-tal)	8.31	0.42	8.46	0.44	8.10	0.41
Ingrowth volume (m ³ ha ⁻¹ year ⁻¹)						
MF Managed Forest	0.048	0.024	0.057	0.020	0.052	0.021
NR Nature Reserve	0.033	0.016	0.059	0.027	0.046	0.016
SR Strict Reserve	0.035	0.011	0.032	0.015	0.033	0.010
Białowieża Forest (to-tal)	0.043	0.016	0.056	0.015	0.049	0.014
Loss volume (m ³ ha ⁻¹ year ⁻¹)						
MF Managed Forest	26.5	8.0	17.2	6.0	21.5	4.6
NR Nature Reserve	15.9	8.3	10.8	4.2	13.2	4.6
SR Strict Reserve	12.8	4.2	12.0	4.3	12.3	3.1
Białowieża Forest (to-tal)	22.3	5.5	15.0	4.0	18.4	3.2
Volume net change (m ³ ha ⁻¹ year ⁻¹)						
MF Managed Forest	-18.0	8.3	-8.8	6.2	-13.4	5.0
NR Nature Reserve	-7.9	8.6	-2.1	4.3	-5.0	4.9
SR Strict Reserve	-4.9	4.3	-4.6	4.4	-4.7	3.2
Białowieża Forest (total)	-14.0	5.7	-6.5	4.1	-10.3	3.4

*) The result for the entire four-year period did not equal the sum of results for periods 2015–2017 and 2017–2019 due to excluding the volume increment of trees that died in the period 2017–2019.

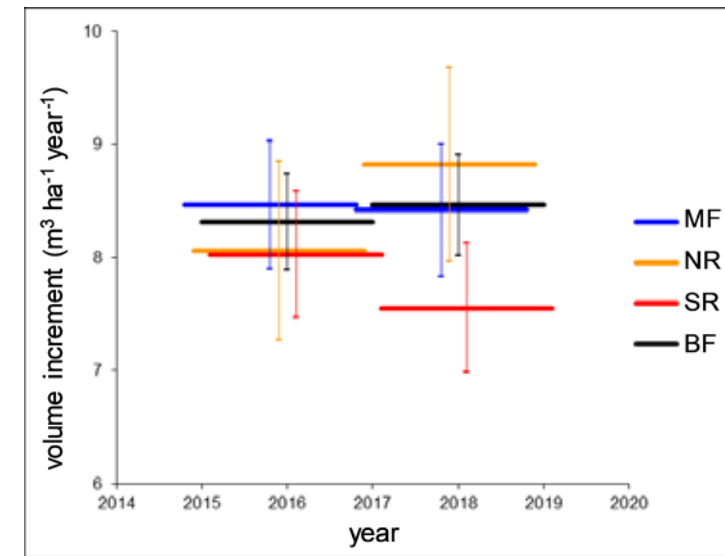

Figure 4.6. Current volume increment in interpretation units of Białowieża Forest stands in the 2015–2017 and 2017–2019 periods. Similarity and differences in mean values (at $p=0.05$): no significant differences. MF – Managed Forest, NR – Nature Reserve, SR – Strict Reserve, BF – Białowieża Forest (Polish part, all interpretation units in total)

4.3.4. Ingrowth volume

Ingrowth volume – *i.e.*, trees that, in a given period, following growth, exceeded the DBH threshold equalled 7.0 cm and passed from the regeneration layer (young tree generation) to the canopy layer – for the 2015–2019 period in Białowieża Forest was 0.049 ± 0.014 m³ ha⁻¹ year⁻¹. This volume varied slightly between the two-year periods (Fig. 4.7, Tab. 4.2). Differences between interpretation units were also insignificant.

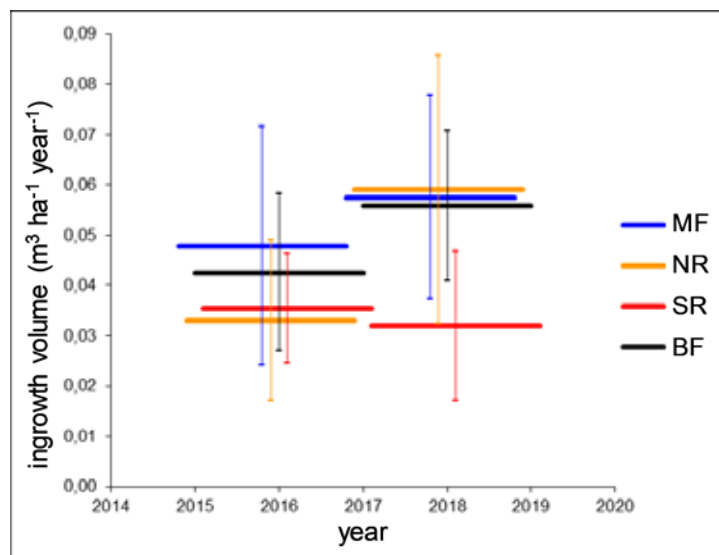

Figure 4.7. Ingrowth volume in interpretation units of Białowieża Forest stands in years 2015–2017 and 2017–2019

Similarity and differences in mean values (at $p=0.05$): no significant differences. MF – Managed Forest, NR – Nature Reserve, SR – Strict Reserve, BF – Białowieża Forest (Polish part, all interpretation units in total).

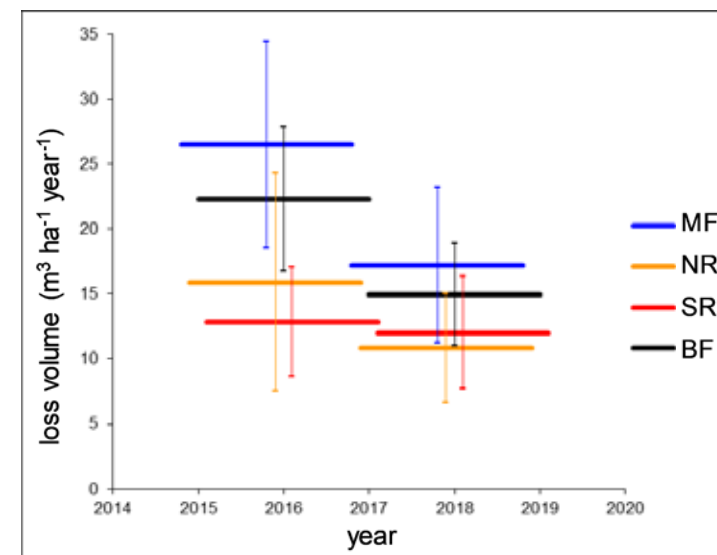

Figure 4.8. Loss volume in interpretation units of Białowieża Forest stands in years 2015–2017 and 2017–2019

Similarity and differences in mean values (at $p=0.05$): BF15–17≠BF17–19; MF≠SR, MF15–17≠SR15–17; other differences – not significant. MF – Managed Forest, NR – Nature Reserve, SR – Strict Reserve, BF – Białowieża Forest (Polish part, all interpretation units in total).

4.3.5. Loss volume

Loss volume – trees that were felled or died in a given period – for the 2015–2019 period in Białowieża Forest was $73.5 \pm 12.8 \text{ m}^3 \text{ ha}^{-1}$ (*i.e.*, $18.4 \pm 3.2 \text{ m}^3 \text{ ha}^{-1} \text{ year}^{-1}$). This was a large amount – far in excess of the volume increment deposited on living trees during the same time period. During the 2015–2017 period, the loss volume was greater (at the limit of significance, $p=0.052$) than during the 2017–2019 period (Fig. 4.8, Tab. 4.2). Over the entire four-year period 2015–2019, the loss volume of MF stands was greater than that in SR stands ($p=0.003$). This result was influenced by the large difference in loss volume between these interpretation units during the 2015–2017 period. The loss volume estimated for the entire four-year period was slightly lower than the sum of loss volume from both periods. This difference was due to the method this feature was estimated based on three dimensions at the beginning of a given period.

The partial loss volume – parts of trunks that broke off from live trees – was small. It was $0.055 \pm 0.028 \text{ m}^3 \text{ ha}^{-1} \text{ year}^{-1}$ in the whole Białowieża Forest in the period 2015–2019. Individual interpretation units differed slightly on this characteristic. Its value was: MF – $0.050 \pm 0.034 \text{ m}^3 \text{ ha}^{-1} \text{ year}^{-1}$, NR – $0.053 \pm 0.060 \text{ m}^3 \text{ ha}^{-1} \text{ year}^{-1}$, SR – $0.104 \pm 0.080 \text{ m}^3 \text{ ha}^{-1} \text{ year}^{-1}$.

4.3.6. Volume net change

The volume net change – *i.e.*, the total change resulting from volume increment and ingrowth (positively acting factors) and loss (negatively acting factor) – for the 2015–2019 period in Białowieża Forest was $-41.1 \pm 13.7 \text{ m}^3 \text{ ha}^{-1}$, *i.e.*, $-10.3 \pm 3.4 \text{ m}^3 \text{ ha}^{-1} \text{ year}^{-1}$. This represented a significant reduction in growing stock volume (compare Fig. 4.1, Tab. 4.2). The volume net change was greater in years 2015–2017 (at the limit of significance, $p=0.058$) than in years 2017–2019 (Fig. 4.9). The difference in the volume net change was most influenced by loss volume, as the volume increment was similar in both periods and across the three interpretation units. Over the entire four-year period 2015–2019, the volume net change in MF stands was greater than that in SR stands ($p=0.012$). This result was influenced by the large difference in loss volume between these units during the 2015–2017 period.

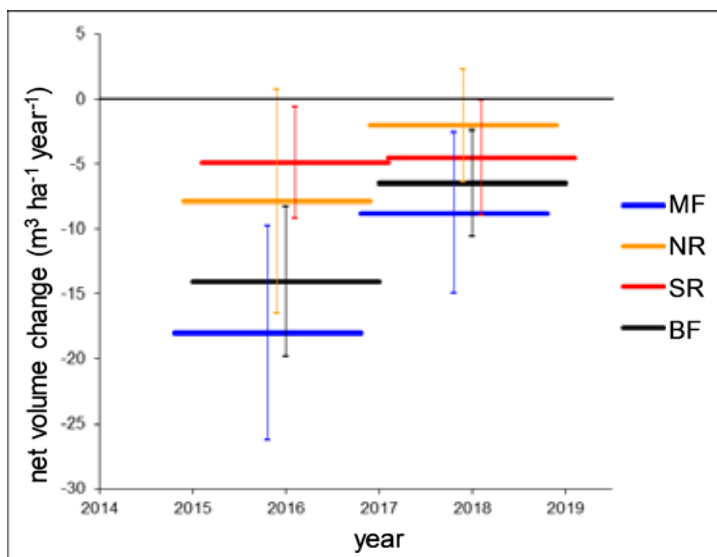

Figure 4.9. Volume net change in interpretation units of Białowieża Forest stands in years 2015–2017 and 2017–2019.

Similarity and differences in mean values (at $p=0.05$): BF15–17≠BF17–19; MF≠SR, MF15–17≠SR15–17; other differences – not significant. MF – Managed Forest, NR – Nature Reserve, SR – Strict Reserve, BF – Białowieża Forest (Polish part, all interpretation units in total)

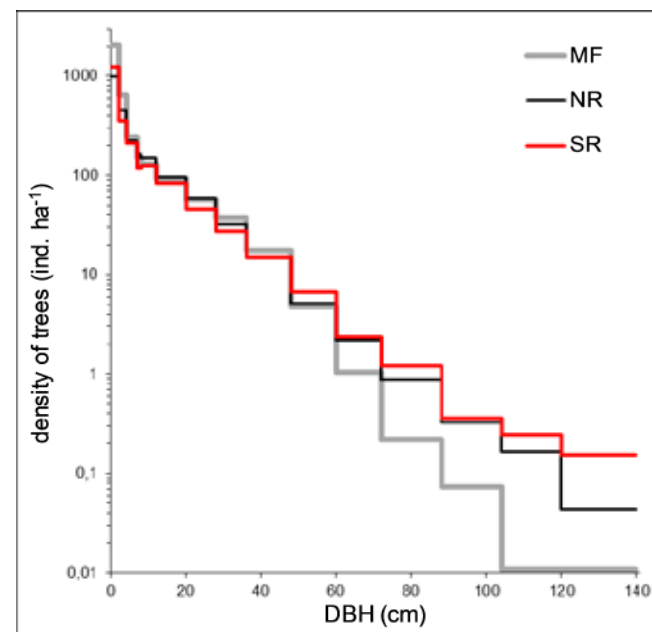

Figure 4.10. Tree density in size classes in interpretation units of Białowieża Forest stands in 2019.

The DBH classes are of different widths, but the density of trees in them is recalculated to be related to a 4 cm wide class. MF – Managed Forest, NR – Nature Reserve, SR – Strict Reserve

4.3.7. Tree size structure

In each interpretation unit, the tree density curve (addressed for the square-unit) was regular. The larger the DBH, the fewer trees were in a given size class (Fig. 4.10, Tab. 4.3). In SR stands there were more thick trees (with $DBH \geq 48$ cm) than in the stands of the other interpretation units. At the same time, medium ($DBH=12-47.9$ cm) and thin ($DBH < 12.0$ cm) trees were the least in this unit. There were relatively few trees with $DBH \geq 60$ cm in MF stands.

NR and SR stands were similar in the tree density in size classes. This was true for both 2015 and 2019, and comparisons were made considering the dimensions of trees with $DBH \geq 7$ cm as well as $DBH > 0$ cm along with the two height classes of the smallest trees (Tab. 4.1). The tree density structure in size classes in NR stands was partially similar to the tree density structure in MF stands, and different between MF and SR stands.

Table 4.4. Value of res index of similarity of tree density structure in size classes between interpretation units in years 2015 and 2019 ($res < 0.5$ similar distributions, $res = 0.5-1.0$ partially similar distributions, $res > 1.0$ dissimilar distributions).

Assessment	Number of classes	SR-MF 2015	SR-MF 2019	SR-NR 2015	SR-NR 2019	NR-MF 2015	NR-MF 2019
All tree dimensions	16	1.06	1.08	0.13	0.12	0.65	0.68
Only trees $DBH \geq 7.0$ cm	11	1.27	1.48	0.15	0.09	0.69	0.96

Table 4.3. Tree density in size classes in interpretation units of Białowieża Forest stands in 2015 and 2019; MF – Managed Forest, NR – Nature Reserve, SR – Strict Reserve.

Size class	Interpretation unit, year					
	MF		NR		SR	
	2015	2019	2015	2019	2015	2019
$h < 0.3$ m	9584	5263	11156	5464	17448	12388
$h = 0.3-1.3$ m	4591	2667	3055	2824	3585	3937
DBH=0.1-1.9 cm	2515	1017	511	489	503	621
DBH =2-3.9 cm	270	321	231	224	170	176
DBH =4-6.9 cm	177	181	178	169	152	160
DBH =7-7.9 cm	47	38	59	41	41	30
DBH =8-11.9 cm	145	132	163	149	135	125
DBH =12-19.9 cm	203	185	214	193	176	167
DBH =20-27.9 cm	130	115	124	117	95	90
DBH =28-35.9 cm	86	74	70	64	56	55
DBH =36-47.9 cm	57	52	49	46	46	45
DBH =48-59.9 cm	17	14	16	15	23	20
DBH =60-71.9 cm	5.0	3.1	7.3	6.6	7.8	7.1
DBH =72-87.9 cm	1.5	0.9	3.5	3.5	5.6	4.8
DBH =88-103.9 cm	0.3	0.3	1.3	1.3	1.3	1.4
DBH =104-119.9 cm	-	-	0.7	0.7	0.9	1.0
DBH =120-199.9 cm	0.1	0.1	-	0.2	0.8	0.8

4.3.8. Sum of height of young generation trees (regeneration layer)

The sum of tree heights in the regeneration layer, consisting of seedlings (trees with height $h < 0.3$ m), low saplings (trees with height range $h = 0.3-1.3$ m or $DBH = 0.1-1.9$ cm) and high saplings ($DBH = 2.0-6.9$ cm) in Białowieża Forest was quite big in 2015 and 2017. This was influenced by the amount of regeneration in MF stands (Fig. 4.11, Tab. 4.5). During the 2017–2019 period in this interpretation unit, the sum of tree heights decreased (but was not a significant change) and became similar to the amount in the other two units. Variability in the sum of regeneration tree heights was much greater in MF than in the other two interpretation units due to the greater irregularity of regeneration occurrence (in the form of separate young stands). The large error in estimating the sum of tree heights in MF influenced the fact that the differences in mean sum of tree heights between interpretation units were insignificant.

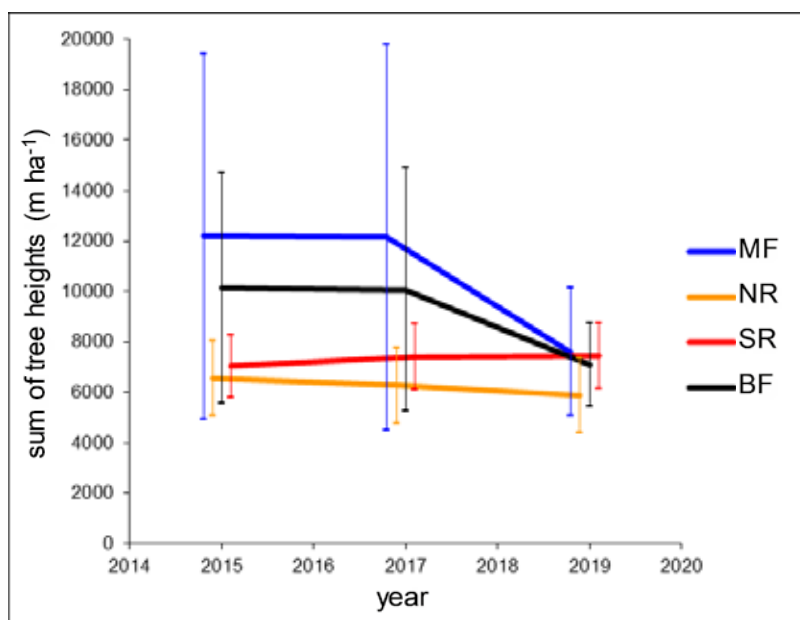

Figure 4.11. Sum of tree heights in the regeneration layer in interpretation units of Białowieża Forest stands in 2015, 2017, and 2019.

Similarity and differences in mean values (at $p=0.05$): no significant differences. MF – Managed Forest, NR – Nature Reserve, SR – Strict Reserve, BF – Białowieża Forest (Polish part, all interpretation units in total)

Table 4.5. Sum of tree heights in the regeneration layer (seedlings $h < 1.3$ m; low saplings $h = 0.3-1.3$ m or $DBH = 0.1-1.9$ cm, high saplings $DBH = 2.0-6.9$ cm) in interpretation units of Białowieża Forest stands in 2015, 2017, and 2019; standard error SE at $p=0.05$

Feature Interpretation unit	Year					
	2015		2017		2019	
	mean	SE	mean	SE	mean	SE
Sum of tree heights, total regeneration layer (m ha⁻¹)						
MF Managed Forest	12192	7234	12138	7659	7593	2541
NR Nature Reserve	6558	1495	6262	1487	5891	1478
SR Strict Reserve	7037	1233	7412	1313	7438	1300
Białowieża Forest (total)	10143	4558	10055	4823	7090	1652
Sum of tree heights, seedlings (m ha⁻¹)						
MF Managed Forest	1278	479	959	355	765	304
NR Nature Reserve	1310	452	984	392	837	350
SR Strict Reserve	2046	600	1967	570	1809	492
Białowieża Forest (total)	1351	331	1049	253	872	219
Sum of tree heights, low saplings (m ha⁻¹)						
MF Managed Forest	8414	7058	8344	7226	3958	2151
NR Nature Reserve	2924	1054	3034	1016	2874	957
SR Strict Reserve	3217	780	3606	878	3678	915
Białowieża Forest (total)	6403	4437	6422	4542	3622	1378
Sum of tree heights, high saplings (m ha⁻¹)						
MF Managed Forest	2500	662	2836	863	2870	1014
NR Nature Reserve	2324	751	2244	717	2180	714
SR Strict Reserve	1774	501	1839	521	1950	568
Białowieża Forest (total)	2390	469	2583	580	2595	669

4.3.9. Sum of tree heights in the seedling layer

Sum of tree heights in the seedling layer (trees with a height $h < 0.3$ m) in Białowieża Forest decreased between 2015 and 2019 ($p < 0.001$) (Fig. 4.12, Tab. 4.5). The amount of seedlings was greater in SR than MF stands ($p = 0.006$). This was associated with smaller variation in light conditions on the forest floor in SR (compared to the stands of the other units), yet with greater shading on average. This influenced the slower growth of the smallest trees, and therefore their remaining in the seedling layer longer.

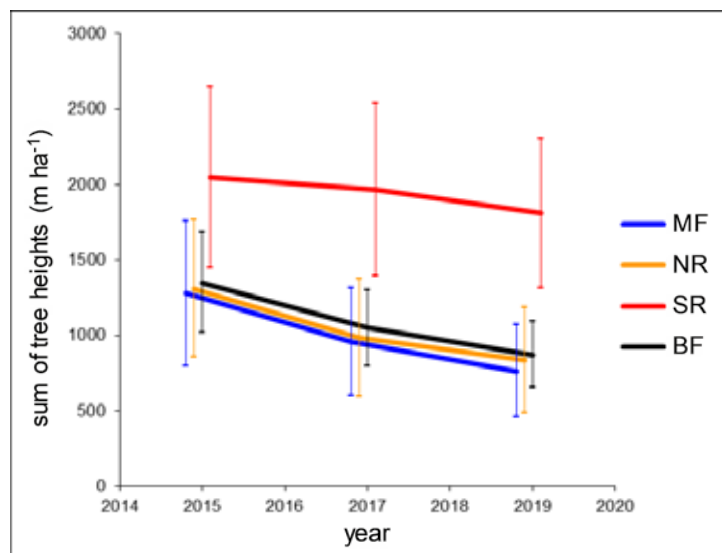

Figure 4.12. Sum of tree heights in the seedling layer ($h < 0.3$ m) in interpretation units of Białowieża Forest stands in 2015, 2017, and 2019.

Similarity and differences in mean values (at $p = 0.05$): BF15 \neq BF17, BF15 \neq BF19; SR \neq MF, MF15 \neq MF19; MF17 \neq SR17; MF19 \neq SR19; other differences – not significant. MF – Managed Forest, NR – Nature Reserve, SR – Strict Reserve, BF – Białowieża Forest (Polish part, all interpretation units in total)

4.3.10. Sum of tree heights in the low sapling layer

The sum of tree heights in the low sapling layer (with height $h = 0.3$ -1.3 m or DBH=0.1-1.9 cm) in Białowieża Forest decreased during the 2017–2019 period (Fig. 4.13, Tab. 4.5), but this change was not significant. This was influenced by the high variability in the number of low saplings in MF stands. During the 2017–2019 period, the sum of low sapling heights in this interpretation unit decreased and became similar to its amount in the other two units.

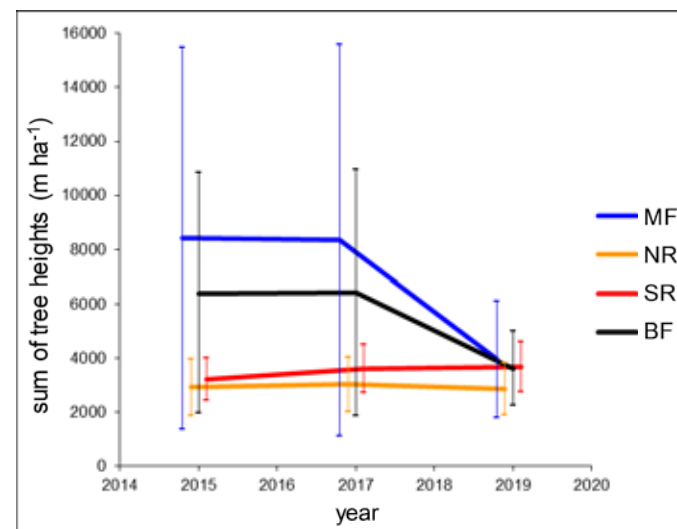

Figure 4.13. Sum of tree heights in the low sapling layer (with height $h = 0.3$ -1.3 m or DBH=0.1-1.9 cm) in interpretation units of Białowieża Forest stands in 2015, 2017 and 2019.

Similarity and differences in mean values (at $p = 0.05$): no significant differences. MF – Managed Forest, NR – Nature Reserve, SR – Strict Reserve, BF – Białowieża Forest (Polish part, all interpretation units in total)

4.3.11. Sum of tree heights in the high sapling layer

The sum of tree heights in the high sapling layer (with DBH=2.0-6.9 cm) in Białowieża Forest remained almost unchanged during the 2015–2019 period (Fig. 4.14, Tab. 4.5). There was only slightly less sum of high sapling heights in SR stands, and the differences in the amount of high saplings between the stands of interpretation units were insignificant.

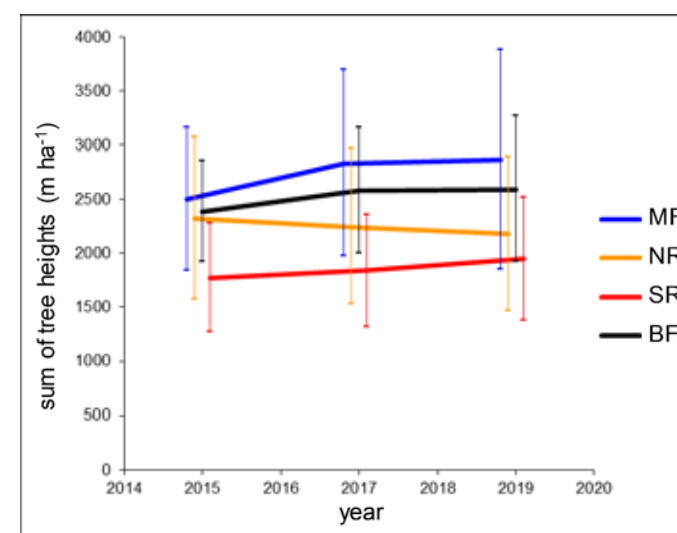

Figure 4.14. Sum of tree heights in the high saplings layer (with DBH=2.0-6.9 cm) in interpretation units of Białowieża Forest stands in 2015, 2017 and 2019.

Similarity and differences in mean values (at $p = 0.05$): no significant differences. MF – Managed Forest, NR – Nature Reserve, SR – Strict Reserve, BF – Białowieża Forest (Polish part, all interpretation units in total)

4.3.12. Tree species composition in stand layers

In the relatively short four-year period 2015–2019, the rather diverse tree species composition of the canopy layer (trees with $DBH \geq 7.0$ cm) of Białowieża Forest stands changed (Fig. 4.15, Tab. 4.6). This was due to a decrease in Norway spruce volume and, to a lesser extent, ash volume. In 2015, spruce had the largest share (32%), but in 2019, Scots pine had the largest share (23%). In the stands of each interpretation unit, changes in tree species composition occurred at different degrees. Based on Morisita's index, it was estimated that the tree species composition of SR stands changed the least and of MF stands changed the most. Interpretation units differed from each other. The tree species composition of MF and SR stands was least similar, while of SR and NR stands, as well as of MF and NR stands, was most similar.

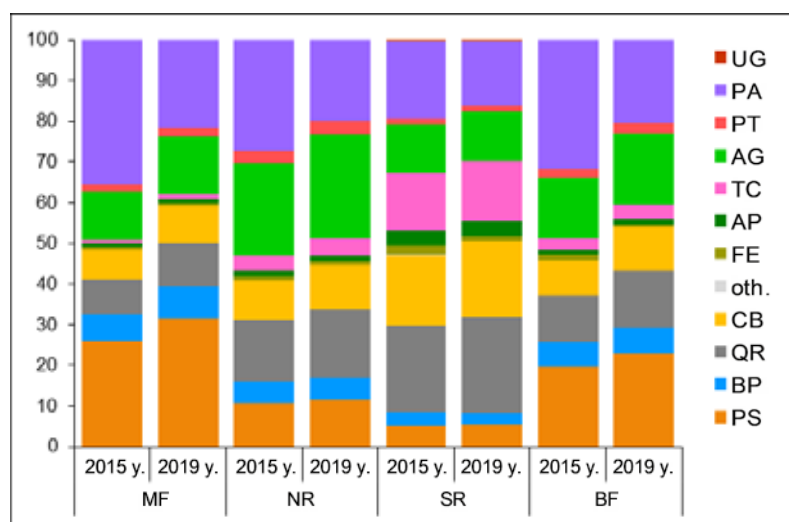

Figure 4.15. Tree species composition by volume of the canopy layer (with $DBH \geq 7.0$ cm) in interpretation units of Białowieża Forest stands in 2015 and 2019

Degree of similarity: MF15-MF19=0.941, NR15-NR19=0.980, SR15-SR19=0.994, BF15-BF19=0.957, MF15-NR15=0.878, MF19-NR19=0.833, MF15-SR15=0.693, MF19-SR19=0.657, NR15-SR15=0.872, NR19-SR19=0.854. MF – Managed Forest, NR – Nature Reserve, SR – Strict Reserve, BF – Białowieża Forest (Polish part, all interpretation units in total); UG – elm, PA – Norway spruce, PT – common aspen, AG – black alder, TC – small-leaved lime, AP – Norway maple, FE – European ash, CB – common hornbeam, QR – oak, BP – birch, PS – Scots pine, oth. – other.

Table 4.6. Share of tree species by volume of the canopy layer (with $DBH \geq 7.0$ cm) in interpretation units of Białowieża Forest stands in 2015 and 2019; MF – Managed Forest, NR – Nature Reserve, SR – Strict Reserve, BF – Białowieża Forest

Tree species	Interpretation unit, year							
	MF		NR		SR		BF	
	2015	2019	2015	2019	2015	2019	2015	2019
Birch	6.8	7.7	5.1	5.3	3.4	3.0	6.0	6.5
Oak	8.3	10.6	15.2	17.0	21.4	23.6	11.5	13.9
Hornbeam	7.2	9.2	9.5	10.8	17.2	18.6	8.8	10.6
other	0.0	0.0	0.1	0.0	0.0	0.0	0.0	0.0
Ash	0.9	0.6	1.3	1.0	2.4	1.2	1.2	0.8
Maple	0.8	1.0	1.3	1.4	3.7	3.7	1.2	1.4
Lime	0.9	1.2	3.7	4.2	13.9	14.9	2.9	3.4
Black alder	11.6	14.1	22.7	25.4	12.1	11.9	14.9	17.4
Aspen	1.9	2.4	3.3	3.6	1.2	1.4	2.2	2.6
Pine	26.0	31.6	10.8	11.5	5.1	5.3	19.6	22.8
Spruce	35.5	21.4	27.1	19.8	19.3	16.2	31.6	20.4
Elm	0.1	0.1	0.0	0.0	0.2	0.1	0.1	0.1

During the 2015–2019 period, the tree species composition of the regeneration layer in Białowieża Forest changed less than that of the canopy layer (Fig. 4.16, Tab. 4.7). This change in composition, defined in terms of the sum of tree heights, was largely influenced by the decrease in the amount of hornbeam in the low saplings layer in MF stands. In this interpretation unit, the similarity in tree species composition of the regeneration layer between 2015 and 2019 was the lowest. There was the least similarity in tree species composition of the regeneration layer between interpretation units in SR and MF stands. In all interpretation units and in each date, hornbeam was the most abundant species.

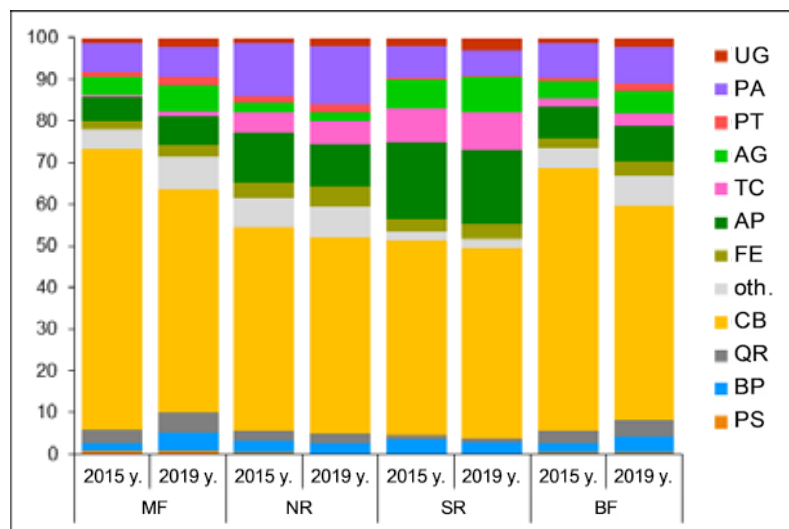

Figure 4.16. Tree species composition by the sum of tree height of the regeneration layer in interpretation units of Białowieża Forest stands in 2015 and 2019.

Degree of similarity: MF15-MF19=0.972, NR15-NR19=0.998, SR15-SR19=0.998, BF15-BF19=0.979, MF15-NR15=0.939, MF19-NR19=0.974, MF15-SR15=0.911, MF19-SR19=0.947, NR15-SR15=0.976, NR19-SR19=0.960. MF – Managed Forest, NR – Nature Reserve, SR – Strict Reserve, BF – Białowieża Forest (Polish part, all interpretation units in total); UG – elm, PA – Norway spruce, PT – common aspen, AG – black alder, TC – small-leaved lime, AP – Norway maple, FE – European ash, CB – common hornbeam, QR – oak, BP – birch, PS – Scots pine, oth. – other

Table 4.7. Share of tree species by the sum of tree height of the regeneration layer in interpretation units of Białowieża Forest stands in 2015 and 2019; MF – Managed Forest, NR – Nature Reserve, SR – Strict Reserve, BF – Białowieża Forest. Białowieskiego Parku Narodowego, PB – Puszcza Białowieska (cała polska część)

Tree species	Interpretation unit, year							
	MF		NR		SR		BF	
	2015	2019	2015	2019	2015	2019	2015	2019
Birch	1.9	4.6	2.8	2.6	3.3	2.8	2.2	4.0
Oak	3.2	4.8	2.5	2.1	1.1	1.0	3.0	3.8
Hornbeam	67.6	53.6	48.9	47.2	47.0	45.9	63.0	51.4
other	4.7	7.9	7.1	7.4	1.8	2.2	5.0	7.3
Ash	1.9	2.9	3.5	5.1	3.2	3.5	2.2	3.5
Maple	5.8	6.7	12.2	10.1	18.4	17.9	7.7	8.5
Lime	0.6	1.3	4.9	5.4	8.0	9.0	1.8	2.9
Black alder	4.3	6.2	2.0	2.3	6.9	8.4	4.0	5.4
Aspen	1.0	2.2	1.6	1.7	0.5	0.4	1.1	1.9
Pine	0.6	0.5	0.3	0.0	0.0	-	0.5	0.4
Spruce	6.9	7.2	12.7	14.1	7.8	6.0	8.0	8.7
Elm	1.5	2.2	1.4	2.0	1.8	3.0	1.5	2.2

Tree species composition of the seedlings layer ($h < 0.3$ m) differed from the overall species composition of the entire regeneration layer (Fig. 4.17, Tab. 4.8). In all interpretation units and at each date, Norway maple was the most abundant species by sum of tree heights. The most numerous species in this layer were hornbeam, ash, and spruce. During the 2015–2019 period, the tree species composition of the seedlings layer in Białowieża Forest, as well as in the stands of each interpretation unit, changed little. There was also considerable similarity in seedling species composition between interpretation units. The greatest difference was between SR and MF stands.

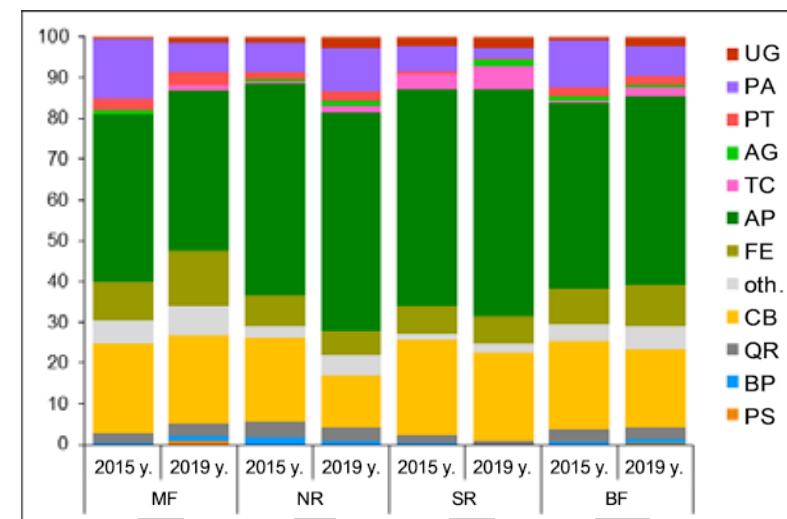

Figure 4.17. Tree species composition by the sum of tree heights in the seedlings layer ($h < 0.3$ m) in interpretation units of Białowieża Forest stands in 2015 and 2019.

Degree of similarity: MF15-MF19=0.983, NR15-NR19=0.987, SR15-SR19=0.996, BF15-BF19=0.994, MF15-NR15=0.966, MF19-NR19=0.936, MF15-SR15=0.955, MF19-SR19=0.935, NR15-SR15=0.995, NR19-SR19=0.975. MF – Managed Forest, NR – Nature Reserve, SR – Strict Reserve, BF – Białowieża Forest (Polish part, all interpretation units in total); UG – elm, PA – Norway spruce, PT – common aspen, AG – black alder, TC – small-leaved lime, AP – Norway maple, FE – European ash, CB – common hornbeam, QR – oak, BP – birch, PS – Scots pine, oth. – other

The tree species composition of the low saplings layer (trees with height $h = 0.3$ – 1.3 m or DBH = 0.1 – 1.9 cm) was dominated by hornbeam (Fig. 4.18, Tab. 4.9). Its share in this layer in the entire Białowieża Forest was so high, especially in 2015 (73%), that the other species could only be described as admixture. During the 2015–2019 period, the species composition of the low saplings layer changed due to a decrease in the amount of hornbeam. Overall, the species composition of low saplings layer in stands of interpretation units was similar. The biggest difference occurred between MF and NR stands. In the low saplings layer in SR, in addition to hornbeam, species with significant contributions were: lime, black alder, maple, and spruce; in NR: spruce, lime, ash, and (collectively) “other” species (willows, rowan, wild fruit trees); and in MF: only “other” species. Although black alder dominated the canopy layer in NR stands, its proportion was very small in the low saplings layer.

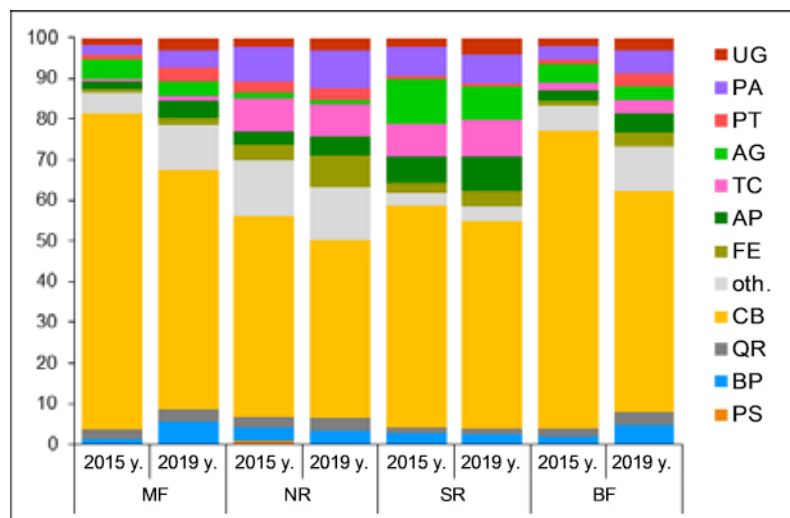

Figure 4.18. Tree species composition by the sum of tree heights in the low saplings layer (with height $h=0.3-1.3$ m or $DBH=0.1-1.9$ cm) in the interpretation units of Białowieża Forest stands in 2015 and 2019.

Degree of similarity: MF15-MF19=0.955, NR15-NR19=0.990, SR15-SR19=0.995, BF15-BF19=0.954, MF15-NR15=0.887, MF19-NR19=0.944, MF15-SR15=0.928, MF19-SR19=0.962, NR15-SR15=0.958, NR19-SR19=0.953. MF – Managed Forest, NR – Nature Reserve, SR – Strict Reserve, BF – Białowieża Forest (Polish part, all interpretation units in total); UG – elm, PA – Norway spruce, PT – common aspen, AG – black alder, TC – small-leaved lime, AP – Norway maple, FE – European ash, CB – common hornbeam, QR – oak, BP – birch, PS – Scots pine, oth. – other

The tree species composition in the high saplings layer (trees with $DBH=2.0-6.9$ cm) was also dominated by hornbeam (Fig. 4.19, Tab. 4.10). There was little change in the species composition of the high saplings layer in Białowieża Forest during the 2015–2019 period. Also, there were few differences between interpretation units due to this characteristic – the largest was between NR and SR stands. In the high saplings layer in SR, in addition to hornbeam, species with significant proportions were lime, black alder, spruce, and birch; in NR, spruce; and in MF, black alder, spruce, and oak. There was still Scots pine in the high saplings layer in MF, which was not present in the high saplings layer of the other units.

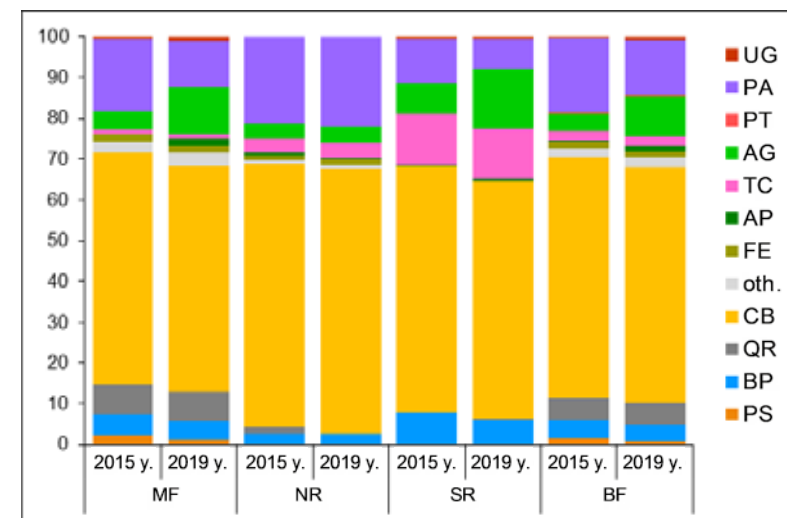

Figure 4.19. Tree species composition by the sum of tree heights in the high saplings layer (with $DBH=2.0-6.9$ cm) in the interpretation units of Białowieża Forest stands in 2015 and 2019.

Degree of similarity: MF15-MF19=0.986, NR15-NR19=0.999, SR15-SR19=0.990, BF15-BF19=0.992, MF15-NR15=0.985, MF19-NR19=0.959, MF15-SR15=0.966, MF19-SR19=0.968, NR15-SR15=0.972, NR19-SR19=0.946. MF – Managed Forest, NR – Nature Reserve, SR – Strict Reserve, BF – Białowieża Forest (Polish part, all interpretation units in total); UG – elm, PA – Norway spruce, PT – common aspen, AG – black alder, TC – small-leaved lime, AP – Norway maple, FE – European ash, CB – common hornbeam, QR – oak, BP – birch, PS – Scots pine, oth. – other

4.3.13. Share, size structure and dynamics of tree species

Birch trees (including silver birch and downy birch) accounted for 6.5% of the tree volume of the canopy layer and slightly less (4.0%) of the total sum of tree heights of the regeneration layer in 2019 throughout the Białowieża Forest. Their volume decreased between 2015 and 2019 ($p=0.032$). They were not represented to the same degree in the stands of each interpretation unit: there were significantly more of them in MF compared to SR ($p=0.018$). In the regeneration layer, the sum of birch tree heights was similar at all inventory dates and in all interpretation units. The proportion of birch trees was relatively higher in the middle DBH classes (Fig. 4.20). There was a fairly high proportion of birch trees in the $h=0.3-1.3$ m size class in MF – probably due to the higher proportion of young, not dense stands.

Oak (mainly pedunculate oak) in 2019 throughout Białowieża Forest accounted for 13.9% of tree volume of the canopy layer (the fourth species by volume) and less (3.8%) of

the total sum of tree height of the regeneration layer. Volume of oak increased in Białowieża Forest during 2015–2019 ($p < 0.001$). This change affected stands of all interpretation units ($p < 0.001$ in all cases). The increase in oak volume was associated with a good survival rate of thick trees that were still increasing in volume. In the young generation, among the thin trees, oak made up a very small proportion of SR and NR stands (Fig. 4.20). There were slightly more thin oaks in MF. Among the very thick trees ($DBH \geq 72$ cm), oak accounted for 45–100% of the number of trees of a given size class. There was significantly bigger oak volume in SR stands compared to MF stands ($p < 0.001$).

Common hornbeam was also a species whose volume increased in Białowieża Forest during the 2015–2019 period. In 2019, its share was 10.6% and as much as 51.4% of the total sum of tree heights in the regeneration layer (four years earlier, 63.0%). Increases in volume of hornbeam occurred in stands of all interpretation units ($p < 0.001$ in all cases). There was significantly bigger hornbeam volume in SR than in NR ($p < 0.001$) and MF ($p < 0.001$) stands. In the regeneration layer, the sum of hornbeam tree heights during the 2015–2019 period remained at similar levels in SR and NR stands, while it decreased insignificantly in MF. In the low and high saplings layer, hornbeam comprised approximately 50–77% of the number of trees in each interpretation unit (Fig. 4.20). It was less in the group of thick trees – with the exception of SR, where its share in some DBH classes was about 30%.

European ash was the species whose volume decreased significantly in Białowieża Forest during the 2015–2019 period ($p < 0.001$) and was 0.8% in 2019. This was only 59% of the volume compared to the year 2015. Ash volume was the highest in SR and the lowest in MF stands, but these differences were not significant. Volume of ash decreased significantly in SR stands between 2015 and 2019 ($p < 0.001$). In the regeneration layer, ash accounted for 3.5% of the total sum of tree height. This quantity did not vary significantly between interpretation units or between dates. Ash was a fairly abundant species in the seedlings and low saplings layers (Fig. 4.20). In the high saplings layer and in the group of thin trees of the canopy layer, the contribution of this species was negligible or even absent in some of the DBH classes, which concerned SR stands to the greatest extent. A small proportion of ash was still recorded in the thick DBH classes.

In 2019, in the stands of Białowieża Forest, **Norway maple** accounted for 1.4% of the volume of the canopy layer, but as much as 8.5% of the total sum of tree heights of the regeneration layer (the third most abundant species). During the 2015–2019 period, volume of maple did not change in the entire Białowieża Forest or in individual interpretation units, but the amount of maple in the regeneration layer decreased (at the significance limit of $p = 0.061$). Maple volume was greater in SR than in MF stands ($p = 0.010$), as was the sum of tree heights of the regeneration layer ($p = 0.041$). Maple was the most abundant species in the seedlings layer – 42–57% of all trees (depending on the interpretation unit), but its proportion in the low saplings layer was already much smaller (Fig. 4.20). There was very little of it in the high saplings layer and among the thin trees of the canopy layer, and in some DBH classes practically none at all. In the thick DBH classes, maple had a small share.

The volume of **small-leaved lime** in the stands of Białowieża Forest was relatively small. Its share in 2019 was 3.4%. The proportion of lime in the regeneration layer was slightly higher – according to the sum of tree heights it was 5.4%. During 2015–2019, volume of lime did not change in any of the interpretation units, but the sum of tree heights of the regeneration layer increased in both the entire Białowieża Forest ($p = 0.027$) and SR stands ($p = 0.012$). In SR stands, the mean volume of lime was significantly greater than in NR ($p < 0.001$) and MF ($p < 0.001$) stands. Likewise, the sum of tree heights in the regeneration layer for this species was significantly greater in SR than in NR ($p < 0.053$) and MF ($p < 0.001$) stands. Differences between interpretation units were evident with respect to the proportion of lime in each DBH-class (Fig. 4.20). In each of these units, there was a relatively small quantity of lime in the seedlings layer. In SR stands, there was a large share of lime in the group of trees with medium and very large DBH (with a clear depression in class $DBH = 60$ – 71.9 cm). In NR stands this structure was similar, although the proportion of lime in the DBH classes was much smaller. There were no thick limes in MF stands.

In 2019, in the stands of Białowieża Forest, **black alder** accounted for 17.4% of the volume of the canopy layer (the third species in terms of volume), but less (5.4%) of the sum of tree height of the regeneration layer. In none of the interpretation units during the 2015–2019 period the average black alder volume did not change, nor did the sum of tree heights of the regeneration layer. Black alder volume in the NR stands was significantly greater than in MF ($p = 0.011$) and SR ($p = 0.028$) stands. Due to rapid growth in youth, the proportion of black alder in the seedlings layer was low (Fig. 4.20). On the other hand, the proportion of trees of this species in the low and high saplings layer was quite big (although it was different in NR), and further in the group of trees with medium or large DBH.

Common aspen belonged to a group of sparse species. In 2019, the proportion of its volume in the canopy layer in the stands of Białowieża Forest was 2.6%. In the regeneration layer, aspen accounted for 1.9% of the total sum of tree heights. In the period 2015–2019, the mean volume of aspen increased ($p = 0.040$). Although volume of aspen was greatest in NR stands, individual interpretation units did not differ significantly. On the other hand, the amount of aspen in the regeneration layer was significantly higher in MF compared to its amount in SR stands ($p = 0.028$). Aspen had, in proportion to the abundance of this species, a relatively high share in the low saplings layer, as well as in the thick DBH-classes (Fig. 4.20).

Elm (mainly wych elm, with a small admixture of field elm) was a sparse species. Its share in the canopy layer in Białowieża Forest in 2019 was 0.07%, but in the regeneration layer this share was higher at 2.2%. Average volume of elm did not change between 2015 and 2019 and stands of each interpretation unit did not differ in the amount of this species. There was a relatively high amount of elm in the seedlings and low saplings layers (Fig. 4.20). Except for rare cases – DBH of the thickest elm trees did not exceed 28 cm. In MF stands, the proportion of elm in the high saplings layer and in the thin DBH-classes of the canopy layer was greater than in the other two interpretation units.

Scots pine was the main tree species by volume in the canopy layer of Białowieża Forest stands in 2019. Its share was 22.8%. Mean volume of Scots pine was greater in MF than NR ($p=0.004$) and SR stands ($p<0.001$). Between 2015 and 2019, mean pine volume increased in both the entire Białowieża Forest ($p=0.005$) and MF stands ($p<0.001$). The proportion of pine in the regeneration layer was very small and was 0.4% in 2019 in Białowieża Forest. The amount of regeneration for this species was similar in stands of all interpretation units and decreased slightly from 2015 to 2019. There were large numbers of pine in the thick DBH-classes (Fig. 4.20). In MF stands it reached 37-42% in some DBH-classes. The thinnest recorded Scots pines in SR stands belonged to the 12-19.9 cm DBH-class. Similarly, there was a very low proportion of pine in the seedlings layer, low and high saplings layer in NR and MF stands.

Norway spruce was the second (by volume) species in the canopy layer of Białowieża Forest stands in 2019. Its share was 20.4%. However, as recently as 2015, spruce was the main tree species (31.6%). In 2019, it was recorded at 58% of the 2015 volume and was one of two species (apart from ash) whose volume decreased so significantly ($p<0.001$). There was a significant decrease in the volume of Norway spruce in MF ($p<0.001$) and NR stands ($p=0.006$). In 2015, the volume of this species was greater in MF than in SR stands ($p<0.001$), but four years later the interpretation units did not differ by spruce volume. In the regeneration layer, the proportion of Norway spruce was 8.7% and according to the sum of tree heights, it was the second species by proportion. In Białowieża Forest, the total sum of tree height of this species decreased during the 2015–2019 period ($p<0.001$), wherein this change was associated with a significant decrease in regeneration in MF stands ($p<0.001$). In the other interpretation units, the amount of regeneration for this species remained similar. The stands of the interpretation units differed to some extent because of the proportion of Norway spruce in the size classes (Fig. 4.20). In all units, the proportion of spruce in the seedlings and low saplings layers was small – less than 10%. In MF and NR stands, there was a relatively high proportion of spruce in the thin and thick DBH classes, with a “depression” in the medium DBH classes. In SR stands, the proportion of this species in the group of trees with medium DBH was quite large and became smaller as the size class increased.

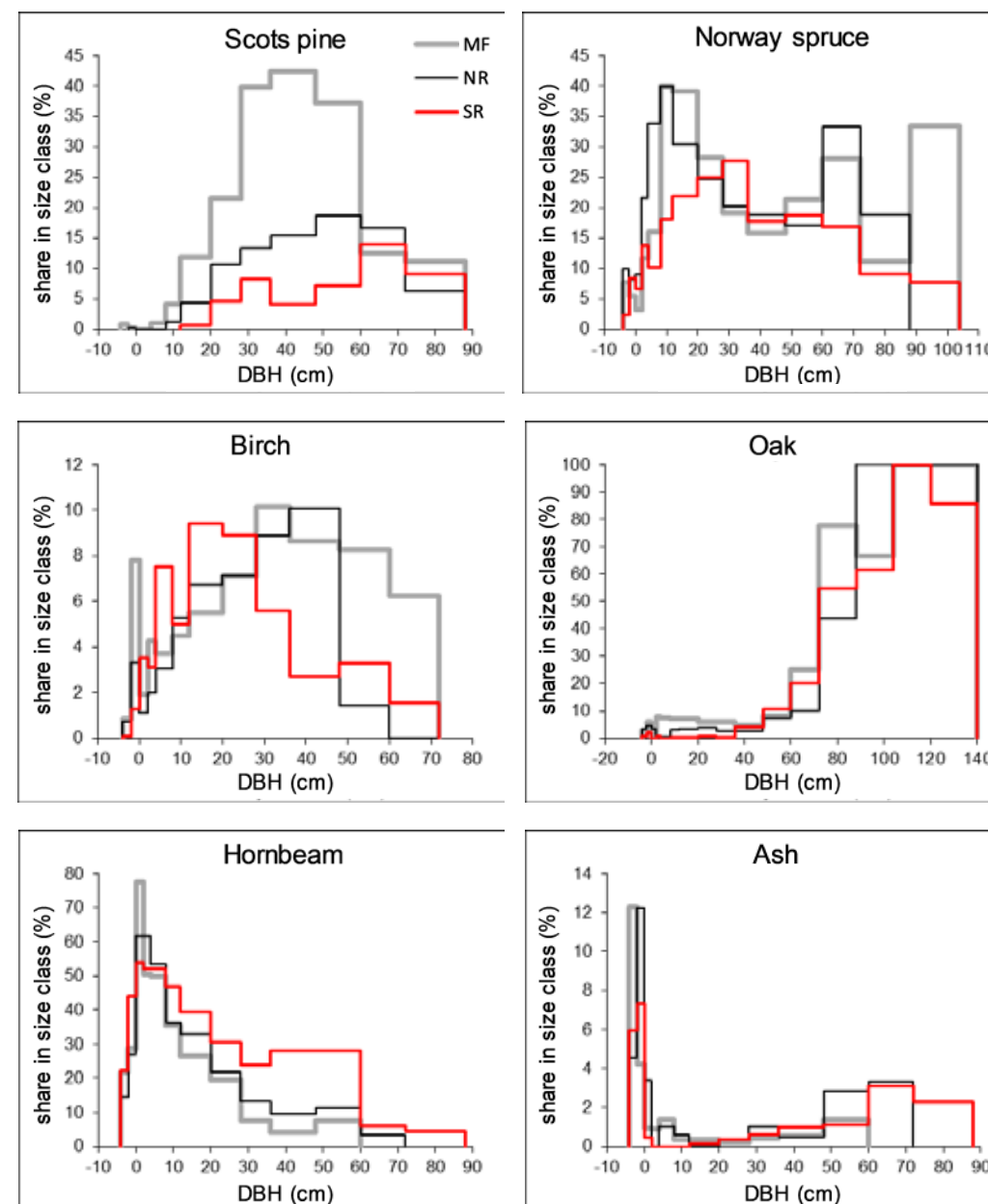

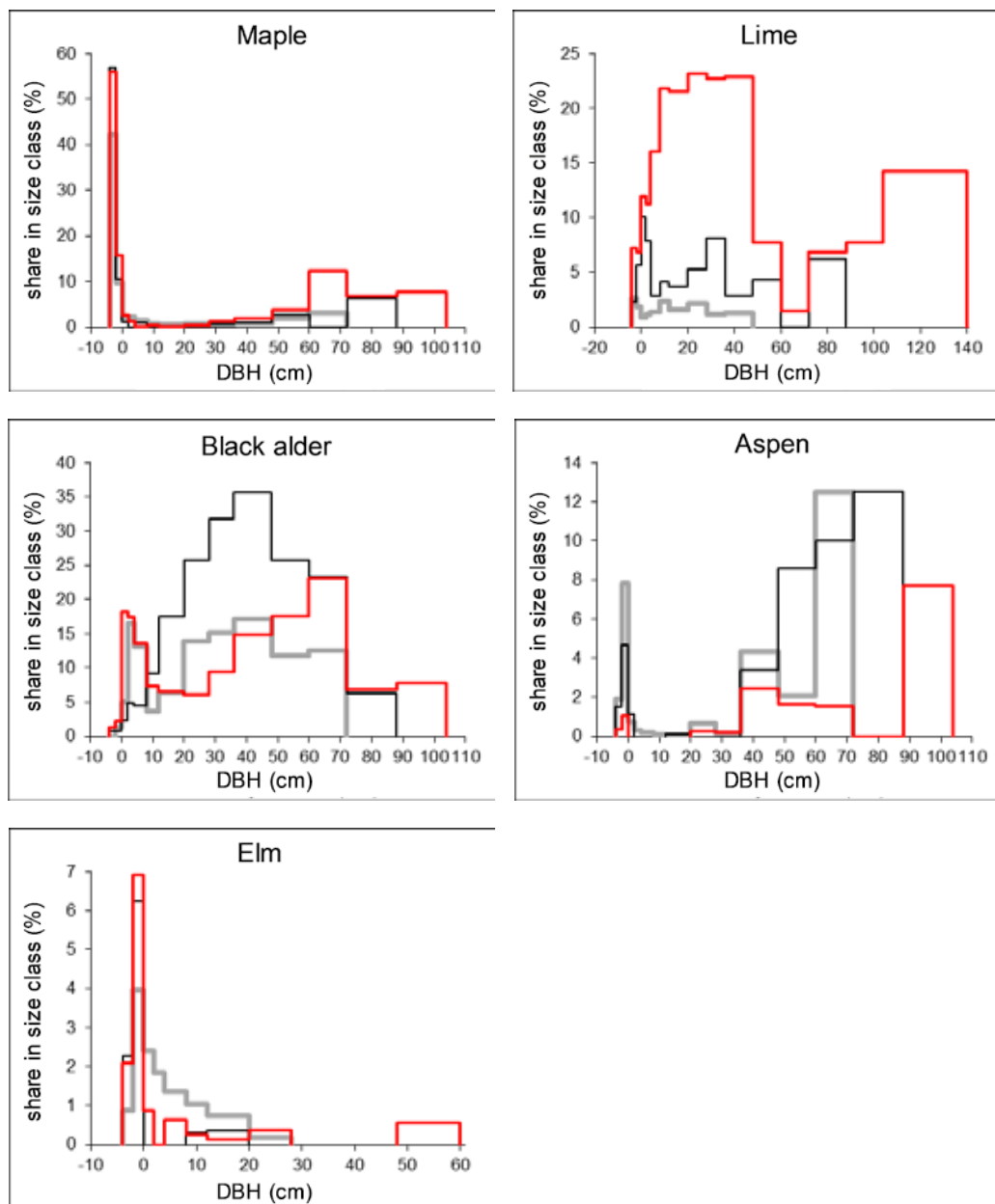

Figure 4.20. The proportion of a given tree species in size classes in stands of interpretation units. Number of trees of all species in a given dimension class = 100%. The two smallest classes (illustrated by negative values) represent the seedlings layer ($h=0.3-1.3$ m) and the saplings layer ($h=0.3-1.3$ m). All figures use the same colour symbols (explained in the figure for pine). MF – Managed Forest, NR – Nature Reserve, SR – Strict Reserve

4.3.14. Damage caused by herbivorous ungulate mammals

The share of trees belonging to the height class $h=0.3-1.3$ m with last-year-sector of the main shoot browsed illustrated how much pressure herbivorous ungulate mammals had on the young generation of trees, and at the same time how attractive each species was (Fig. 4.21). This proportion, averaging (regardless of tree species) over 40% in Białowieża Forest, was relatively high. The most damaged species were elm, hornbeam, and ash; the least damaged black alder, birch, and spruce. The low proportion of browsed aspen trees (a species generally heavily damaged) was unusual.

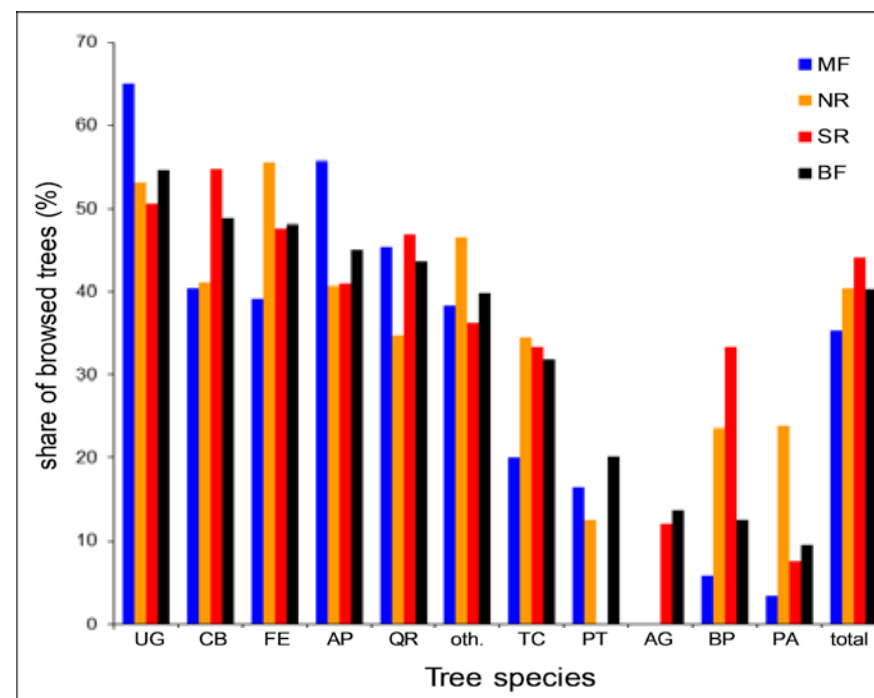

Figure 4.21. Proportion of trees of height class $h=0.3-1.3$ m with the main shoot browsed during the year (since April of the previous year until April of the present year, i.e. browsing of the last-year-sector of the main shoot), by herbivorous ungulate mammals; for aspen and black alder, data were omitted for units with too few observations. MF – Managed Forest, NR – Nature Reserve, SR – Strict Reserve, BF – Białowieża Forest (Polish part, all interpretation units in total)

The smoothed relationship between the share of browsed trees and tree height also confirmed the differences in the degree of damage between the stands of the interpretation units. In the case of hornbeam (the most numerous tree species in the regeneration layer), the dimensions of the most “attractive to be browsed” trees differed: in MF stands, there were trees of 0.45 m high, in NR they were already 0.8 m high, and slightly more (0.85 m) in SR stands (Fig. 4.22a). In the last unit, the proportion of browsed hornbeams was the highest (which was consistent with the average data for the $h=0.3-1.3$ m height class). For maple (the most numerous tree species in the seedling layer), the dimensions of the most “attractive to be browsed” trees did not differ (Fig. 4.22b). In all interpretation units it was 1.0 m high. In MF stands maple was more browsed than in the other units.

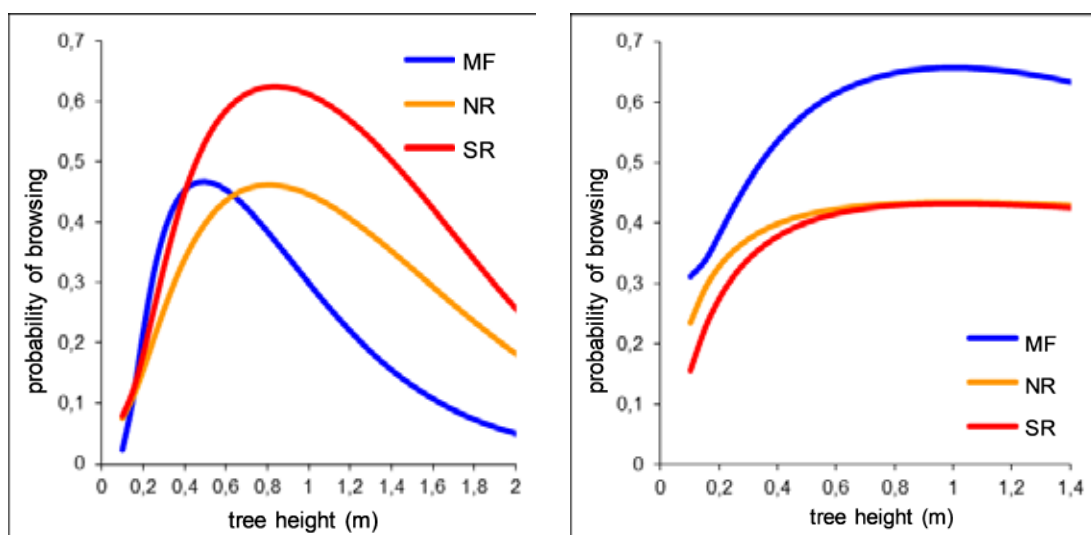

Figure 4.22. Browsing probability of hornbeam (a – left panel) and maple (b – right panel) during one year in different interpretation units in Białowieża Forest. MF – Managed Forest, NR – Nature Reserve, SR – Strict Reserve

The density of trees with stem surface damage, *i.e.* bark-stripped or frayed by herbivorous ungulates, was on average 149 ± 27 ind. ha^{-1} in Białowieża Forest. It was similar in the stands of all interpretation units (Fig. 4.23) and was: MF – 164 ± 39 ind. ha^{-1} , NR – 116 ± 37 ind. ha^{-1} , SR – 140 ± 34 ind. ha^{-1} . The number of trees with new wounds (occurred within one year) was 22 ± 13 ind. ha^{-1} and it was also similar in the three units: MF – 25 ± 20 ind. ha^{-1} , NR – 17 ± 14 ind. ha^{-1} , SR – 22 ± 24 ind. ha^{-1} . There were more trees that had only healed wounds, and the largest number of trees were those that had at least one old open wound (“old” wound of bark-stripping or fraying).

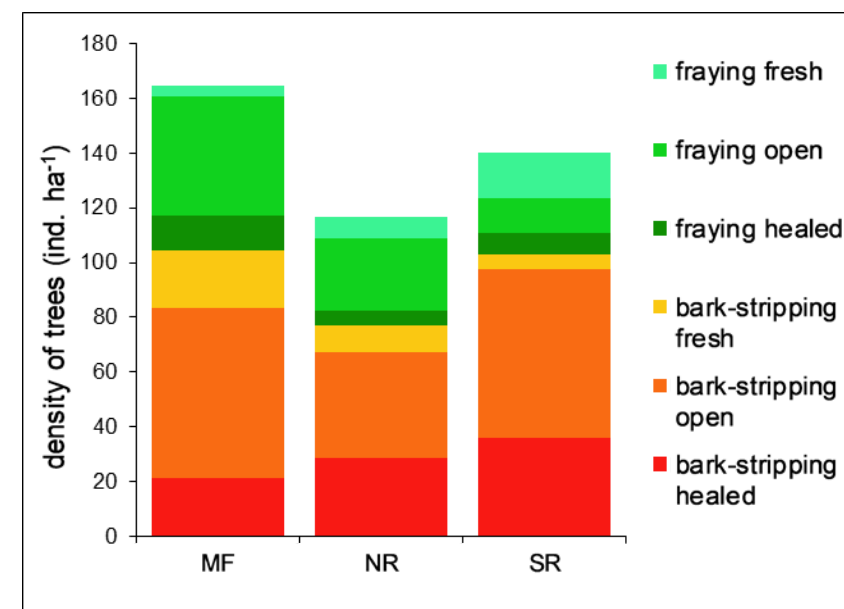

Figure 4.23. Densities of bark-stripped or frayed trees divided into sub-types in stands of interpretation units of Białowieża Forest. MF – Managed Forest, NR – Nature Reserve, SR – Strict Reserve

The proportion of trees damaged by bark stripping or fraying by herbivorous ungulates depended on tree size (Fig. 4.24). In each of the interpretation units of Białowieża Forest stands, the largest proportion with this damage were trees in class $DBH=8.0-11.9$ cm. This was related to the fact that much of the damage occurred when the trees were thin, *i.e.*, DBH within the range of 2.0-11.9 cm. Thicker trees were also subject to damage but to a lesser degree. In the following size classes, beginning with class $DBH=12.0-19.9$ cm, the density of damaged trees decreased. This phenomenon may have been related to the higher mortality of damaged trees, their more frequent elimination in silvicultural treatments (in MF stands, as well as to the healing of wounds that gradually became invisible). In the class $DBH=2.0-7.9$ cm, the proportion of damaged trees was similar in all interpretation units. In the group of trees with $DBH \geq 20.0$ cm in SR, the proportion of trees damaged due to bark stripping or fraying was higher than in the other units.

Similar relationships between the proportion of trees damaged by bark stripping or fraying and their size were in the case of Norway spruce (Fig. 4.25). The difference was in the high proportion of damaged spruces in classes with the $DBH=12.0-19.9$ cm. This was because – due to the thin and smooth bark – the fairly thick spruce trees are still attractive to ungulates that cause bark stripping or fraying.

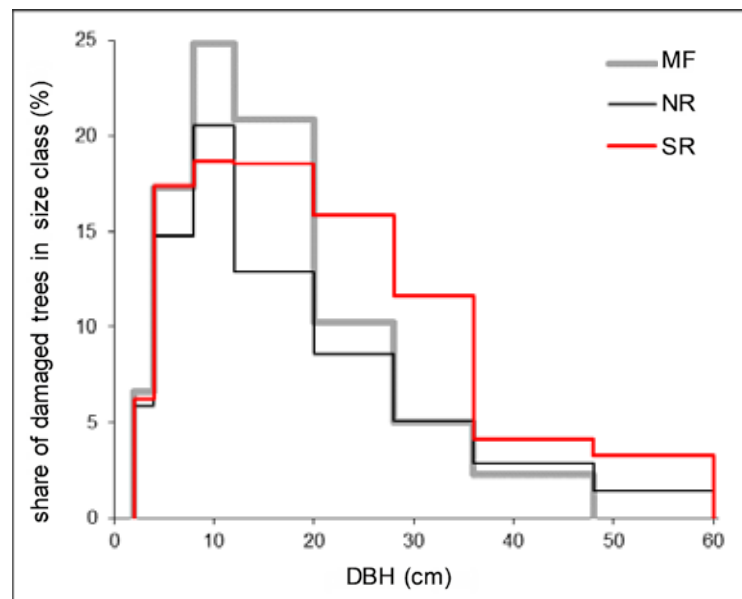

Figure 4.24. Proportion, in size classes, of trees damaged (bark stripping or fraying) by herbivorous ungulate mammals in stands of interpretation units in Białowieża Forest; data for all tree species; number of trees in a given class =100%. MF – Managed Forest, NR – Nature Reserve, SR – Strict Reserve

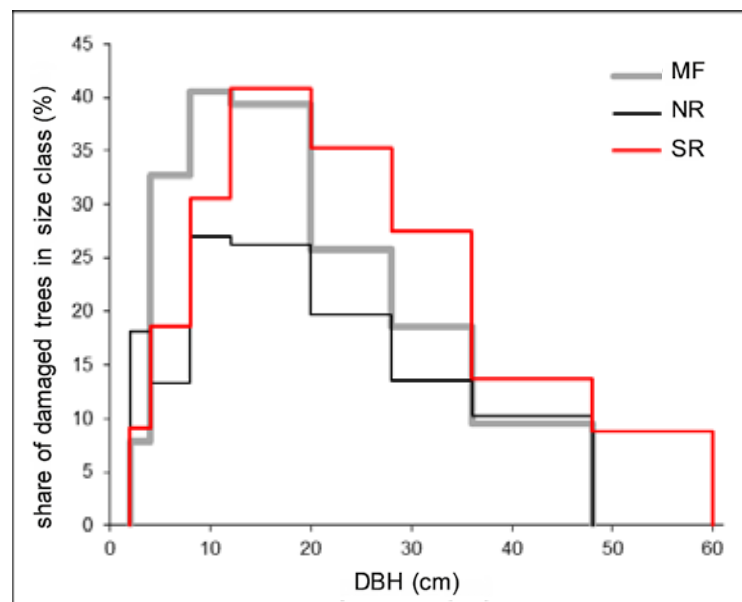

Figure 4.25. Proportion, in size classes, of Norway spruce damaged (bark stripping or fraying) by herbivorous ungulate mammals in stands of interpretation units of Białowieża Forest; number of trees in a given class =100%. MF – Managed Forest, NR – Nature Reserve, SR – Strict Reserve

4.4. Discussion

In the ForBioSensing project, for the first time, the analysis of the state and dynamics of wood resources was carried out for the whole area of the Polish part Białowieża Forest using the same method for collecting inventory data collection in individual parts of this object. The reference to the previous state of the forest was possible only in the case of the Strict Reserve of Białowieża National Park, and even with some limitations. Results from 1990 (Michalczuk 2001), 1995 and 2005 (Krasuska, Miścicki 2002; Miścicki 2012), from years 1999–2009 (Brzeziecki *et al.* 2010), from the period 2000–2015 (Miścicki 2016), and from the period 1999–2019 (Brzeziecki *et al.* 2020) were obtained using different methodological approaches.

In this study, the results on the state of wood resources were interpreted not only for the entire Białowieża Forest, but also for stands in three separate interpretation units: Managed Forests (MF), Nature Reserve (NR), and Strict Reserve (SR). The criteria for defining these units were historical differences in forest management and protection. The number of sample plots measured in 2015–2019 was sufficient to assess the state and dynamics of the stands in these three interpretation units, but was too small to divide them further by considering forest habitat structure. This would be useful, for example, in interpreting differences in tree species composition of the stands. Brzeziecki *et al.* (2019) used 16 interpretation units (four habitat groups multiplied by four management and/or protection units) and data obtained from 1373 sample plots (every fourth centre of the sample plot coincided with the centre of the sample plot of the set used in this study). It is difficult to directly compare the results of the two studies. The general trends in changes in wood resources were similar, but, for example, the average volume of stands in Białowieża Forest and some interpretation units (two of them – MF and SR – were the same as units used in this study) differed (in this study they were slightly bigger). The reasons for this could be complex. It is likely that the influence of a difference in the number of sample plots and their size was small (500 m² for the canopy tree layer assessment in this study versus 400 m² in the cited studies). To a greater extent, this difference may have resulted from the use of different formulas for calculating the individual tree volume. The quality of the results – especially those obtained from measurements using numerous sample plots – may also depend on the correctness of the data, which is related, among other things, to the careful control of the results of the field measurements. In the cited studies by Brzeziecki *et al.* (2019), in addition to assessing the status and dynamics of wood resources, the issue of comparing protected stands of Białowieża Forest with managed stands was also addressed. Among the 42 characteristics and parameters used, in 21 cases no differences were found between these units, in 11 cases the result indicated superiority of protected stands over managed stands, but in 10 cases the opposite was true.

Comparisons of the state and development of protected forest with managed forest have been done elsewhere in Europe (Keren *et al.* 2017; Keren, Diaci 2018; Keren *et al.* 2018). However, such a comparison in the case of Białowieża Forest had the advantage that the object under strict protection (SR) is relatively large. Its size (about 4600 ha) is sufficient for the state of the wood resources, subject to the processes of life, surviving, loss and ingrowth, to

be stable. Was the state of the wood resources really balanced in SR during the study period, as well as in the other two interpretation units (NR and MF), with an area even larger than that of SR?

Previous studies on SR of Białowieża National Park indicated that the growing stock volume (GSV) of forest stands decreased to a small extent in the period 1990–2005 (Miścicki 2012), but was stable in the period 2000–2015 (Miścicki 2016). Previous studies conducted in SR stands showed that GSV slightly decreased in the period 1990–2005 (Miścicki 2012), but was stable in the period 2000–2015 (Miścicki 2016). According to this study, volume of SR stands decreased to a small extent in the period 2015–2019 (and the least among the analysed interpretation units). This result partially coincides with the results of the study by Brzeziecki *et al.* (2020). According to these authors, the average volume of BNP Strict Reserve decreased by an average of $2.9 \text{ m}^3 \text{ ha}^{-1} \text{ year}^{-1}$ during the period 2009–2019. According to the present study, it decreased by an average of $4.7 \text{ m}^3 \text{ ha}^{-1} \text{ year}^{-1}$ in the period 2015–2019, so in absolute values the latter result was bigger. However, it should be taken into account that the result presented in this study concerned the period of particularly intensive tree dieback – especially of Norway spruce. GSV in Białowieża Forest decreased significantly during the period 2015–2019. This was due to the high tree mortality, but also due to the decrease in current volume increment, which could be assessed by comparing the data for SR. During the period 2000–2015 volume increment amounted in SR $9.0 \text{ m}^3 \text{ ha}^{-1} \text{ year}^{-1}$, and $7.6 \text{ m}^3 \text{ ha}^{-1} \text{ year}^{-1}$ in 2015–2019. In 2019, the average GSV in the Polish part of Białowieża Forest was similar to that recorded before the outbreak of World War I, which was $372 \text{ m}^3 \text{ ha}^{-1}$ (Więcko 1984). This figure should be treated as an approximation, as it concerned the entire forest at that time. The decline in GSV during 2015–2019 was a surprising phenomenon due to its intensity. According to the prognosis of Gazda and Miścicki (2016), the average volume of SR stands should increase by $3 \text{ m}^3 \text{ ha}^{-1}$ in the ten-year period 2015–2025.

There were fewer differences in tree species composition of the regeneration layer between interpretation units. In the high saplings layer, traces of past management in stands of MF could still be seen. This was expressed by the presence of relatively numerous oaks and less numerous pines. In the other interpretation units, the share of these species in the high saplings layer was smaller, and was small in the low saplings and seedlings layers in all interpretation units. Everywhere in the low and high saplings layers, the most numerous was hornbeam. However, a new situation was the dominance of maple in the seedlings layer. Limiting comparisons to SR only, because for that unit only there are earlier (since 1995) data available for the regeneration layer, the proportion of some species in the lowest tree layers has changed (Miścicki 2012). The proportion of hornbeam and ash in the seedlings and low saplings layer decreased, while the proportion of maple increased. It is difficult to assess whether a change in the proportion of maple and hornbeam will also occur in the future in the low and high saplings layer, and further in the canopy layer. This will be affected by damage – mainly browsing – caused by herbivorous ungulates mammals. The results of the present study confirmed that young trees were intensively damaged, and that hornbeam and maple belonged to the group of tree species highly favoured by these animals. However, hornbeam is resilient to damage, while maple is much less so (Kuijper *et al.* 2010). The proportion of

browsed trees, as well as the density of trees with damaged trunk surfaces (bark-stripped or frayed), differed, although not too much, among the interpretation units. This could be related to the abundance of a particular tree species and the form of its occurrence in the regeneration layer. It could also be influenced by the species composition of ungulates in a given area, since tree species are not equally attractive as food for individual species of these animals (v. Raesfeld 1970, 1971).

In the past, the stands of the interpretation units differed by the growing conditions of the young trees and, consequently, by the attractiveness of their shoots as food. Most often they grew under the canopy of old trees in SR and NR, and quite often in open areas in MF. Young trees growing in good light conditions are considered the most attractive as food for ungulates. However, the restriction on silvicultural measures resulted in changes in young tree growth condition in the analysed period 2015–2019 in MF. Significant part of the young trees grew under the canopy layer.

Due to previously unanticipated events, the four-year study period conducted in 2015–2019 coincided with intense changes occurring in the stands of Białowieża Forest. The most significant phenomenon was spruce dieback, which led to significant disturbance of stand structure (or “catastrophe”, to use another term). It was pointed out that such significant disturbances, which could be prevented in the managed part of the forest, lead to a deterioration of the conservation status of many valuable elements of the natural richness of Białowieża Forest (Brzeziecki *et al.* 2018). Without entering into a discussion here as to what were the causes of the significant rate of spruce decline, it is worth mentioning its impact on Białowieża Forest. In the 2015–2019 period, the volume of dead trees in Białowieża Forest was 4.173 million m^3 , of which 2.750 million m^3 (66%) was spruce. It was estimated that in the period 1915–1918 the occupying German administration felled 5 million m^3 in the entire Białowieża Forest and that this was one of the biggest disasters in the history of the Forest (Więcko 1984). Assuming that timber was harvested evenly from the whole area, in the current Polish area of Białowieża Forest was cut 2.20 million m^3 . It should be emphasised that the forest stands suffered losses also in later years: it was estimated that the volume of spruce trees dead as a result of the bark beetle feeding in 1921–1922 amounted to 1.95 million m^3 (Mokrzecki 1923). However, contemporary tree dieback has caused losses in the living wood resources of Białowieża Forest comparable to those of 1915–1922 or even greater.

4.5. Summary

The state and dynamics of wood resources were determined for the entire area of the Polish part of Białowieża Forest, using the same method for collecting inventory data in individual parts of this object. The results were evaluated for the entire Białowieża Forest, but also for stands in three separate interpretation units: Managed Forests (MF), Nature Reserve (NR), and Strict Reserve (SR). The criteria for defining these units were historical differences in forest management and protection.

The four-year research period 2015–2019 coincided with the intense changes that took place in the stands of Białowieża Forest. The most important phenomenon was the dieback of spruce, which led to significant disturbances in the structure of the stands. In 2015–2019, the volume of dead trees in the Polish part of Białowieża Forest was 4.173 million m³, of which 2.750 million m³ (66%) were Norway spruce trees. In general – in the whole forest – volume of stands decreased, although to a small extent in SR (among the analysed interpretation units). Spruce and ash mortality and, to a lesser extent, differences in mortality and increment of other tree species changed the tree species composition of stands in Białowieża Forest.

Differences in tree species composition in the regeneration layer between the interpretation units were smaller. In the high sapling layer, traces of previous management could still be seen in the stands of MF. This was expressed in the presence of relatively numerous oaks and less numerous pines. In all interpretation units, hornbeam was most numerous in the low and high sapling layers. However, the dominance of maple in the seedling layer was a new situation. Young trees were frequently damaged by herbivorous ungulates. On average, about 40% of trees in the height class $h=0.3-1.3$ m were browsed within one year, with elm, hornbeam, ash, and maple being the most affected.

References

- Bernadzki E., Bolibok L., Brzeziecki B., Zajązkowski J., Żybura H. 1998a. Compositional dynamics of natural forests in Białowieża National Park, northeastern Poland. *Journal of Vegetation Science*, 9: 229–238.
- Bernadzki E., Bolibok L., Brzeziecki B., Zajązkowski J., Żybura H., 1998b. Natural stand development in Białowieża National Park between 1936 and 1996. *Fundacja Rozwój SGGW, Warszawa* (in Polish).
- Bruchwald A., Rymer-Dudzińska T., Dudek A., Michalak K., Wróblewski L., Zasada M. 2000. Wzory empiryczne do określania wysokości i pierścicowej liczby kształtu grubizny drzewa. *Sylvan*, 144(10): 5–13.
- Brzeziecki B., Keczyński A., Zajązkowski J., Drozdowski S., Gawron L., Buraczyk W., Bielak K., Szeligowski H., Dzwonkowski M., Ostrowski J., Widawska Z. 2010. Operat dynamiki ekosystemów leśnych Białowieżskiego Parku Narodowego. Unpublished typescript in Department of Silviculture, Warsaw University of Life Sciences, Warsaw.
- Brzeziecki B., Pommerening A., Miścicki S., Drozdowski S., Żybura H. 2016. A common lack of demographic equilibrium among tree species in Białowieża National Park (NE Poland): evidence from long-term plots. *Journal of Vegetation Science*, 27(3): 460–469.
- Brzeziecki B., Hilszczański J., Kowalski T., Łakomy P., Małek S., Miścicki S., Modrzyński J., Sowa J., Starzyk J.R. 2019. Problem masowego zamierania drzewostanów świerkowych w Leśnym Kompleksie Promocyjnym "Puszcza Białowieża". *Sylvan*, 162(5): 373–386.
- Brzeziecki B., Zajązkowski J., Bolibok L. 2019. Ocena stanu różnorodności biologicznej w Puszczy Białowieżskiej na podstawie wybranych elementów przyrodniczych i kulturowych. Unpublished typescript in Department of Silviculture, Warsaw University of Life Sciences, Warsaw.
- Brzeziecki B., Woods K., Bolibok L., Zajązkowski J., Drozdowski S., Bielak K., Żybura H. 2020. Over 80 years without major disturbance, late-successional Białowieża woodlands exhibit complex dynamism, with coherent compositional shifts towards true old-growth conditions. *Journal of Ecology*, 108(3): 1138–1154.
- Czerwiński A. 1968. Baza produkcji leśnej Puszczy. [In:] J.B. Faliński (red.), *Park Narodowy w Puszczy Białowieżskiej*. PWRiL Warszawa: 177–198.
- Gazda A., Miścicki S. 2016. Prognoza zmian składu gatunkowego drzewostanów Białowieżskiego Parku Narodowego. *Sylvan*, 160(4): 309–319.
- Gazda A., Miścicki S. 2018. Sąsiedztwo i następstwo gatunków drzew w Białowieżskim Parku Narodowym. *Sylvan*, 162(3): 209–219.
- Horn H. 1966. Measurement of 'overlap' in comparative ecological studies. *The American Naturalist*, 100: 419–424.
- Instrukcja o urządzaniu lasów w parkach narodowych i rezerwach przyrody. 1962. Ministerstwo Leśnictwa i Przemysłu Drzewnego, Warszawa.
- Instrukcja urządzania lasu 1980. Prace urzędniowe. Ministerstwo Leśnictwa i Przemysłu Drzewnego. PWRiL, Warszawa.
- Keren S., Diaci J., Motta R., Govedar Z. 2017. Stand structural complexity of mixed old-growth and adjacent selection forests in the Dinaric Mountains of Bosnia and Herzegovina. *Forest Ecology and Management*, 400: 531–541.
- Keren S., Diaci J., 2018. Comparing the Quantity and Structure of Deadwood in Selection Managed and Old-Growth Forests in South-East Europe. *Forests*, 9(2): 1–16.
- Keren S., Medarevic M., Obradovic S., Zlokapa B. 2018. Five Decades of Structural and Compositional Changes in Managed and Unmanaged Montane Stands: A Case Study from South-East Europe. *Forests*, 9(8): 1–19.

- Köhl M., Magnussen S., Marchetti M. 2006. Sampling methods, remote sensing and GIS multiresource forest inventory. Springer-Verlag Berlin, Heidelberg, New York.
- Krasuska M., Miścicki S. 2002. Wielkoobszarowa charakterystyka drzewostanów Białowieżskiego Parku Narodowego. *Sylwan*, 146(3): 73–90.
- Kuijper D.P.J., Cromsigt J.P.G.M., Jędrzejewska B., Miścicki S., Churski M., Jędrzejewski W., Kweczlich I. 2010. Bottom-up versus top-down control of tree regeneration in the Białowieża Primeval Forest, Poland. *Journal of Ecology*, 98(4): 888–899.
- Michalak R., Broda J., Głaz J., Jabłoński M., Lech P., Smykała J., Wawrzoniak J., Zajązkowski S. 2004. Instrukcja Wykonywania Wielkoobszarowej Inwentaryzacji Stanu Lasu. Instytut Badawczy Leśnictwa (unpublished typescript).
- Michalczyk C. 2001. Siedliska i drzewostany Białowieżskiego Parku Narodowego. *Phytocoenosis 13 (N.S.) Supplementum Cartographiae Geobotanicae 13*, Warszawa – Białowieża, Ministerstwo Leśnictwa i Przemysłu Drzewnego, Zarząd Ochrony Przyrody.
- Miścicki S. 1996. Forest regeneration and its damage by herbivorous ungulates in Białowieża National Park. [In:] P. Paschalis, S. Zajązkowski (red.), *Biodiversity protection of Białowieża Primeval Forest*. Fundacja „Rozwój SGGW”, Warszawa: 91–108.
- Miścicki S. 2012. Structure and dynamics of temperate lowland natural forest in Białowieża National Park, Poland. *Forestry*, 85(4): 473–483.
- Miścicki S. 2016. Zmiany drzewostanów Białowieżskiego Parku Narodowego w okresie 2000-2015. *Leśne Prace Badawcze*, 77(4): 371–379.
- Miścicki S., Nowicka E. 2007. Pomiar zasobów leśnych z wykorzystaniem stałych koncentrycznych powierzchni próbnych – problemy i próby rozwiązań. *Sylwan*, 151(8): 15–26.
- Mokrzejcki, Z. 1923. Report on the bark beetle control in the Białowieża Primeval Forest in 1922. *Las Polski*, 4(9-10): 297-307 (in Polish).
- Niedziałkowski W. 1949. Wytyczne urządzenia gospodarstwa rezerwatowego wraz z programem prac inwentaryzacyjnych i organizacyjnych w rezerwatach leśnych. Instytut Badawczy Leśnictwa, Rozprawy i Sprawozdania, Seria A, 60: 1–88.
- von Raesfeld F. 1970. *Das Rehwild*. Naturgeschichte, Hege und Jagd (neuarbeitet von G. von Lettow-Vorbeck und W. Rieck). Verlag Paul Parey, Hamburg und Berlin.
- von Raesfeld F. 1971. *Das Rotwild*. Naturgeschichte, Hege und Jagd (neuarbeitet von F. Vorreyer). Verlag Paul Parey, Hamburg und Berlin.
- Więcko E. 1984. *Puszcza Białowieża*. PWN Warszawa.
- Zingg A., Duc Ph. 1998. Beurteilung des Gleichgewichtszustandes in Plenterwaldversuchsflächen. [In:] *Deutscher Verband Forstlicher Forschungsanstalten – Sektion Ertragskunde. Jahrestagung vom 25.-27. Mai 1998, Kevelaer*. Freiburg i. Br. Deutscher Verband Forstlicher Forschungsanstalten: 147–156.

5. Status and dynamics of dead wood volume in Białowieża Forest in 2015–2019 based on data from permanent monitoring plots

Łukasz Kuberski¹, Rafał Paluch¹, Żaneta Piasecka², Ewa Zin¹, Krzysztof Stereńczak²

¹ Forest Research Institute, Department of Natural Forests, 6 Park Dyrekcyjny St., 17-230 Białowieża

² Forest Research Institute, Department of Geomatics, Sękocin Stary, 3 Braci Leśnej St., 05-090 Raszyn
{l.kuberski, r.paluch, z.piasecka, e.zin, k.stereńczak}@ibles.waw.pl

Abstract

Białowieża Forest is a vast ecosystem where spontaneous natural processes, including the emergence and decomposition of dead wood, can be observed. These processes are among the most important factors determining forest biodiversity. As a part of the ForBio-Sensing project, a comprehensive inventory of dead wood (Coarse Woody Debris, CWD) was conducted for the first time in Białowieża Forest in the short timeframe from 2015 to 2019. The study coincided with a substantial dieback of Norway spruce (*Picea abies* (L.) Karst). due to the spruce bark beetle outbreak. The chapter reports on changes in the amount of various types of CWD in the Polish part of Białowieża Forest that occurred between 2015 and 2019 in three conservation categories (BNP Strict Reserve, conservation reserve, managed forest) and four habitat groups (coniferous forests, mixed forests, deciduous forests, alder bog and riparian forests). The inventory was carried out on 477 permanent, circular monitoring plots of 500 m², schematically distributed in a grid of 1300 m × 1300 m squares (322 plots) and a grid of 250 m × 1000 m rectangles in the strict protection area of the Białowieża National Park (155 plots). It was found that the area-weighted average CWD volume in Białowieża Forest in 2019 was 113.2 m³ ha⁻¹, consisting of snags (54%), logs (42%), and stumps (4%). Compared to 2017, the total CWD volume increased by 21%. Compared to 2015, by 2019 the volume of snags has increased more than 2.5-fold. Locally, above-average dead wood volume was recorded. In 2019, the relative CWD volume on 60% of the study plots was higher than 100 m³ ha⁻¹ – most often in the BNP Strict Reserve and conservation reserve.

Keywords: natural forest dynamics, nature conservation regime, forest habitat type, spruce bark beetle outbreak

5.1. Introduction

Białowieża Forest is an ecosystem where spontaneous natural processes can be observed, including the emergence and decomposition of dead wood (i.e., Coarse Woody Debris, CWD). These processes belong to the most important determinants of biodiversity, crucial for numerous, often rare and threatened elements of the forest biota (Bobiec et al. 2005; Blanco and Lo 2012; Gutowski et al. 2012; Stokland et al. 2012; Hilszczański and Jaworski 2018). Dead trees in the form of standing dead wood, scrap wood, and lying dead wood are a permanent component of natural forest biocenoses, especially during the terminal stages of stand development (Miścicki 2016). The presence of dead wood contributes to the mosaicism of microhabitats in a forest ecosystem. Decay of trees causes differences in temperature, humidity, amount of light reaching the forest floor, and uprooting additionally shapes the microrelief of the terrain (Faliński 1978, 1986; Pawlik 2013). The effect of the presence of standing dead trees is an increased penetration of sunlight into the forest interior, which increases the temperature during the day, diurnal temperature amplitude, and slightly heightens wind speed in the forest interior (Harmon et al. 1986).

More and more is known about the relationship between microhabitats formed by dead wood and various systematic groups of organisms (Stockland et al. 2012). The key role of dead wood for biodiversity is particularly evident in the world of insects. So far, 455 species of beetles associated with standing dead trees have been recorded in Białowieża Forest. The coniferous communities are the most valuable in terms of the occurrence of insects associated with dead wood. Up to 30% of species associated with decaying trees occur in other forest habitat types (Byk 2001). Many species of fungi are also associated with dead wood (Lofroth 1998; Bobiec et al. 2005; Hilszczański and Jaworski 2018). The existence of various fungi communities on dead wood ensures proper circulation of matter in the forest ecosystem (Franklin et al. 1981). It should be emphasized that dead wood is a microhabitat that changes its properties as the process of rotting progresses. Therefore, it provides favourable conditions for many species of bryophytes with different habitat requirements. The bryoflora found on dead wood includes both common and endangered species. Therefore, dead wood is of great importance for maintaining an appropriate level of bryophyte diversity in forest ecosystems (Bobiec et al. 2005; Wierzcholska et al. 2018). Dead wood also enables the creation of specific biocenotic bonds, facilitating the coexistence of many related species. One such example is the relationship between small mammals and saproxylic fungi. Mammals involuntarily spread fungal spores, facilitating fungal colonization of subsequent substrates, which increases the food base of these mammals. Moreover, the distribution of fungi changes the migration routes of small mammals (Franklin et al. 1981).

Uprooted trees diversify the microrelief of the forest floor (Faliński 1978; 1986; Fig. 5.1), and dead trunks play an important role in slowing down the runoff of rainwater (Zielonka et al. 2009; Pawlaczyk 2017). Lying dead wood can accumulate water up to 250% of the dry mass of the trunk, forming a water reservoir which – through evaporation – increases the air humidity in the forest (Maser et al. 1988). Tree regeneration is also an inherent process related to tree dieback, which plays a key role in forest dynamics. Dead wood often facilitates it by creating convenient places for seed germination, e.g., stabilizing the soil, regulating water conditions or protecting seedlings and saplings against animal access (Bobiec et al. 2011; Smit et al. 2012).

The volume of dead wood in the forest is not constant, as new fragments of wood appear constantly along with the simultaneous decomposition process (Bujoczek 2012), and its pace depends on several factors, including climatic conditions (Stokland et al. 2012).

In 2015–2019, a significant increase in the amount of dead wood was observed in Białowieża Forest. It was caused by the massive dieback of spruce and ash driven by various factors (Paluch 2015; Brzeziecki et al. 2018; Jaroszewicz and Cholewińska 2018).

The research presented in this chapter aimed to characterize the state and dynamics of dead wood volume in the Polish part of Białowieża Forest in 2015–2019, taking into account the different degrees of its decay, depending on the forest habitat and stand conservation category.



Figure 5.1. Effect of the 2017 windthrow in the compartment 630 of Białowieża Forest (photo Ł. Kuberski, 2020)

5.2. Materials and Methods

In the study, measurement data from 477 circular sample plots from two regular grids were used. The first grid of research plots is the ForBioSensing project grid which was established in 2015 in the Polish part of Białowieża Forest and which is 1300 m × 1300 m in size (322 study plots). The grid was cropped (i.e., inclined by about 30°) relative to the north to avoid overlapping of the study plots with roads and compartment lines, most of which run north-south and east-west in Białowieża Forest. The second of the study plot grids used for the measurements was established in 1999, in the strict protection area of the Białowieża National Park, and is approximately 250 m × 1000 m in size (155 study plots). This grid is away from

the land division lines (see Chapt. 1 and Fig. 5.2). Plots that are located in areas that do not constitute forest according to the Forest Numerical Map were excluded from the analyses.

A survey of dead wood was carried out on 500 m² circular monitoring plots (r = 12.62 m). Standing dead trees and stumps were included in the inventory if the centre of their cross-section fell within the plot. Dead standing trees (hereafter: snags) with DBH (diameter at breast height, i.e., 1.3 m above the ground) ≥ 7.0 cm (in bark) and ≥ 1.3 m in height and stumps with height < 1.3 m and with a diameter at mid-height ≥ 7.0 cm (in bark) were measured. For each of the considered dead standing trees and stumps, the height, diameter (in the case of broken trees, the diameter at the fracture site) and the degree of wood decay were determined according to a 5-point scale (Pyle and Brown 1998) by determining in the field only the first 4 classes, i.e.: I – fresh wood; II – wood partially decayed; III – wood heavily decayed; IV – wood very heavily decayed. In the case of lying dead wood (logs): down woody material lying within the sample plot, with a diameter at the thinner end ≥ 7.0 cm (in bark) were included in the sample. For every element of lying dead wood, the following measurements were taken: length, diameter at the centre, and the degree of wood decay according to the aforementioned rules. Moreover, the tree species and the presence of bark at the point of diameter measurement were determined. Measurements were carried out in 2015, 2017 and 2019, from July to October.

Analyses were conducted for four habitat groups: (1) coniferous forests, (2) mixed forests, (3) deciduous forests, (4) alder bog and riparian forests, and for three stand conservation categories (Tab. 5.1). The first category consisted of the area of the former Strict Reserve of the Białowieża National Park, under strict protection since 1921, hereafter referred to as "BNP Strict Reserve". The second category included stands located in nature reserves and in the former Hwoźna Protection Area of the Białowieża National Park, which was a part incorporated into the park in 1996, hereafter referred to as „conservation reserve”. The third category consisted of stands used for commercial purposes, located outside the Białowieża National Park

Table 5.1. Monitoring plots representing particular forms of stand conservation and habitat groups. The measurement was conducted in 2015, 2017, and 2019, from July to October; BNP – Białowieża National Park

Stand conservation category	Habitat group	Number of plots (n)
Managed forest	coniferous forests	14
	mixed forests	109
	deciduous forests	62
	alder bog and riparian forests	19
Conservation reserve	coniferous forests	8
	mixed forests	33
	deciduous forests	32
	alder bog and riparian forests	18
BNP Strict Reserve	coniferous forests	3
	mixed forests	47
	deciduous forests	114
	alder bog and riparian forests	18

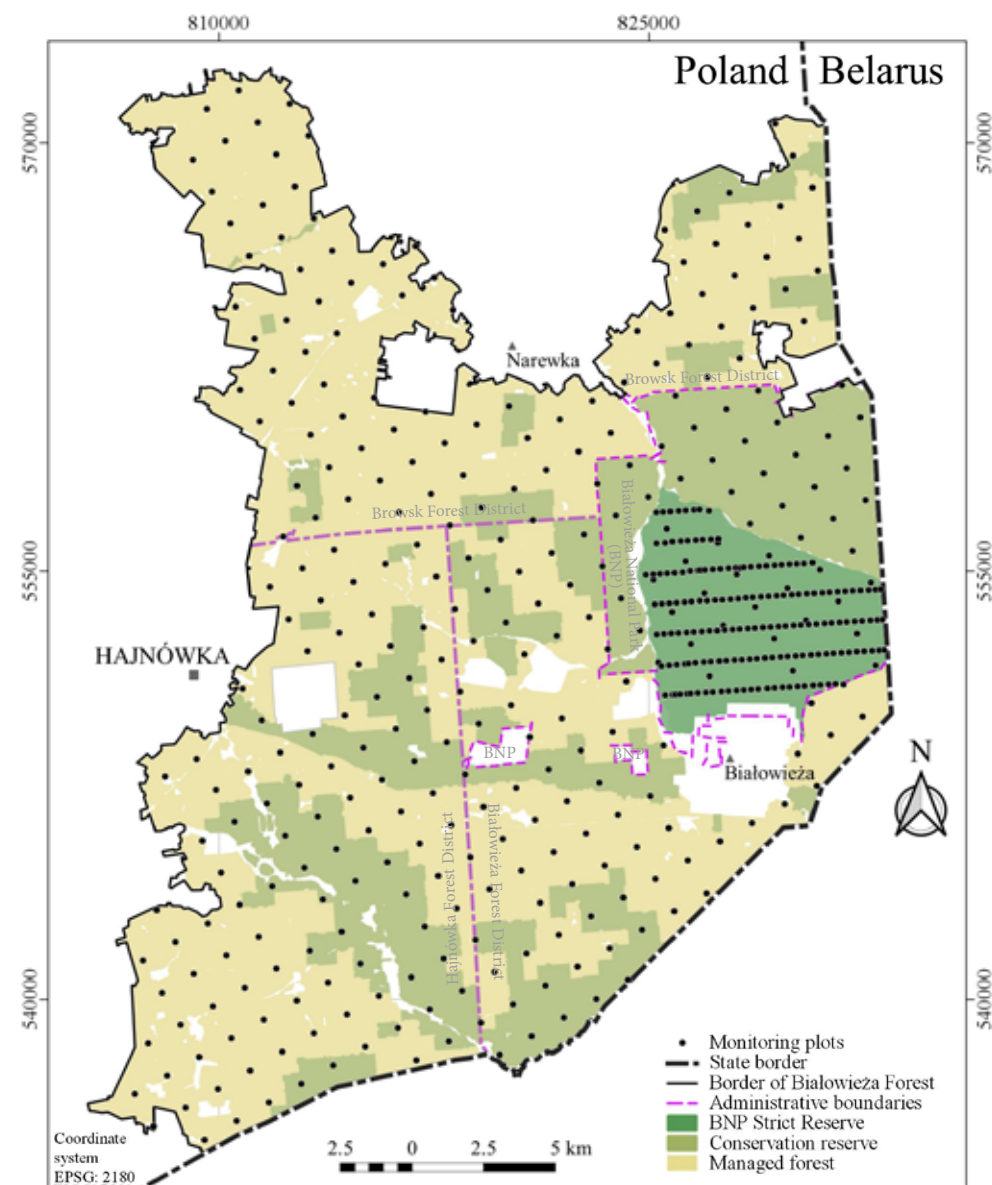

Figure 5.2. Distribution of monitoring plots where data on dead wood volume were collected (n = 477)

and outside nature reserves, hereafter referred to as „managed forest” (Tab. 5.1 and Fig. 5.2). Depending on the level of analysis (conservation category or habitat group), the amount of wood was determined as a weighted average, where the weight was always the area covered by the certain habitat group or conservation category.

The mid-section formula (Huber’s formula) was used to calculate the volume of lying dead wood (logs) and stumps, for standing dead trees (snags) the empirical formula

(Bruchwald et al. 2000) was used. In the case of dead broken trees, the volume was calculated using the formula of 15 sections – developed by Prof. Arkadiusz Bruchwald (an unpublished formula implemented in the ACER programme that allows calculating the volume of broken stems based on the diameter at breast height, height and diameter of the stem at the place of fracture). Volume analyses were conducted excluding bark thickness. The following dead wood volume classes were adopted for visualization on the maps: a) $< 5 \text{ m}^3 \text{ ha}^{-1}$, b) $\geq 5 < 10 \text{ m}^3 \text{ ha}^{-1}$, c) $\geq 10 < 30 \text{ m}^3 \text{ ha}^{-1}$, d) $\geq 30 < 100 \text{ m}^3 \text{ ha}^{-1}$, e) $\geq 100 < 200 \text{ m}^3 \text{ ha}^{-1}$, and f) $\geq 200 \text{ m}^3 \text{ ha}^{-1}$.

5.3. Results

The mean amount of dead wood in Białowieża Forest in 2019 was $113.2 \text{ m}^3 \text{ ha}^{-1}$, of which the volume of dead standing trees was 54% ($60.8 \text{ m}^3 \text{ ha}^{-1}$), lying wood 42% ($48.1 \text{ m}^3 \text{ ha}^{-1}$), and the remaining 4% ($4.3 \text{ m}^3 \text{ ha}^{-1}$) was constituted by stumps. In 2019, compared to 2017, the average value of dead wood volume increased by 21%. Both the average volume of lying dead wood and of standing dead wood increased by over $10 \text{ m}^3 \text{ ha}^{-1}$ within two years. Compared to the first measurement year (2015), the volume of standing dead trees increased by over 2.5 times. A smaller change was recorded in the volume of stumps, which in 2015 was $3.4 \text{ m}^3 \text{ ha}^{-1}$.

The dynamics of dead wood volume varied between habitat groups. In 2019, maximum values were recorded in deciduous forests and alder bog and riparian forests. They were $117.1 \text{ m}^3 \text{ ha}^{-1}$ and $131.2 \text{ m}^3 \text{ ha}^{-1}$, respectively. The third position was occupied by the group of mixed forests with an average volume of dead wood of $110.7 \text{ m}^3 \text{ ha}^{-1}$. Coniferous forests were ranked fourth with a value of $62.1 \text{ m}^3 \text{ ha}^{-1}$. In the category of lying dead wood in 2019, as in 2017, the maximum amount was recorded in the alder bog and riparian forests and was $90.1 \text{ m}^3 \text{ ha}^{-1}$, while in 2017 it was $80.4 \text{ m}^3 \text{ ha}^{-1}$. The lowest values of the average volume of lying dead wood were registered in the coniferous forests and were $25.8 \text{ m}^3 \text{ ha}^{-1}$ in 2019 and $20.3 \text{ m}^3 \text{ ha}^{-1}$ in 2017. In the category of standing dead wood at the beginning of the measurements, i.e. in 2015, the largest amount was in the alder bog and riparian forests (on average $34.4 \text{ m}^3 \text{ ha}^{-1}$), followed by deciduous forests (on average $23.3 \text{ m}^3 \text{ ha}^{-1}$). The situation changed in 2017 when the highest amount of standing dead wood was recorded in mixed forests (on average $57.3 \text{ m}^3 \text{ ha}^{-1}$), followed by deciduous forests (on average $44.8 \text{ m}^3 \text{ ha}^{-1}$). This trend continued in the third measurement series, i.e. in 2019. At that time, an average of $73.6 \text{ m}^3 \text{ ha}^{-1}$ was recorded in mixed forests, and $58.9 \text{ m}^3 \text{ ha}^{-1}$ in deciduous forests. The greatest increase in standing dead wood volume between the first and the last measurement series, i.e., in the period 2015–2019, was recorded in mixed forests. This increase was more than 3.5 times in deciduous forests and more than 2.5 times in coniferous forests. The smallest increase was recorded in alder bog and riparian forests and was 1.1 times (Fig. 5.3).

When considering the stand conservation regime, it was noticeable that in the managed forests and in the BNP Strict Reserve, the highest volume of dead wood was found in alder bog and riparian forests. In contrast, in the conservation reserve the highest volume was re-

corded in mixed forests where approximately $140 \text{ m}^3 \text{ ha}^{-1}$ of dead wood was found in 2019 (Fig. 5.4).

These results indicate a significant increase in the volume of standing dead trees in the study period (2015–2019) (Fig. 5.3–5.4). This phenomenon is less pronounced in the BNP Strict Reserve (Fig. 5.4).

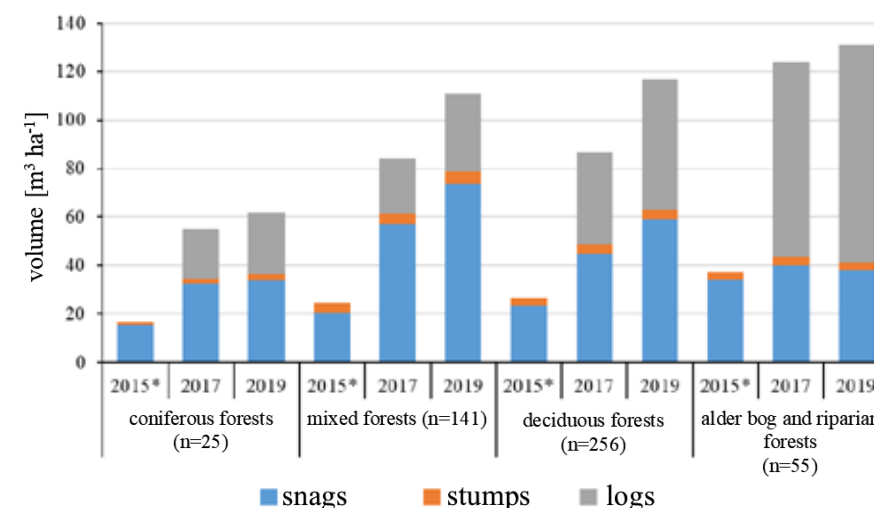

Figure 5.3. Average (area weighted) volume of dead wood in the Polish part of Białowieża Forest in 2015, 2017, and 2019, with reference to habitat groups, * – logs were not considered

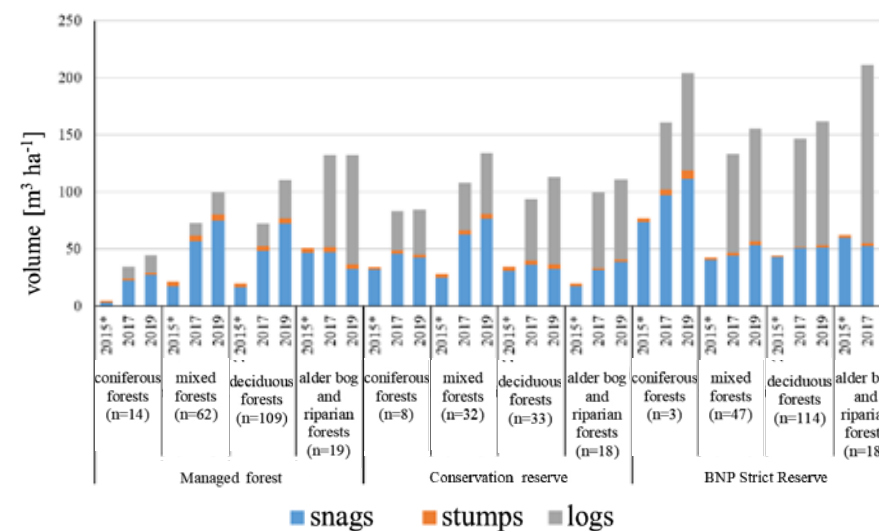

Figure 5.4. Average (area weighted) volume of dead wood in the Polish part of Białowieża Forest in 2015, 2017, and 2019, in habitat groups depending on the conservation category, * – logs were not considered

The highest values of dead wood volume were found in the longest protected area, i.e. in the BNP Strict Reserve. In 2019, an average of 167 m³ ha⁻¹ was recorded there, and this value increased by about 10 m³ ha⁻¹ during the analysed period (Fig. 5.4). This increment appeared due to an increase in the lying dead wood (Fig. 5.5). The amount of standing dead wood in three measurement surveys in the BNP Strict Reserve oscillated between 40 and 60 m³ ha⁻¹. In the conservation reserve, the average dead wood volume in 2019 was nearly 120 m³ ha⁻¹. Lying dead wood was prevalent. The most dynamic increase in the volume of dead wood took place in the managed forests. This increase was mainly shaped by the increase in the volume of standing dead trees. In 5 years, the amount of standing dead wood in managed forests increased more than 3.5 times, from about 20 m³ ha⁻¹ recorded in 2015 to nearly 70 m³ ha⁻¹ in 2019. The total average amount of dead wood in managed forests was over 100 m³ ha⁻¹ in 2019 (Fig. 5.5).

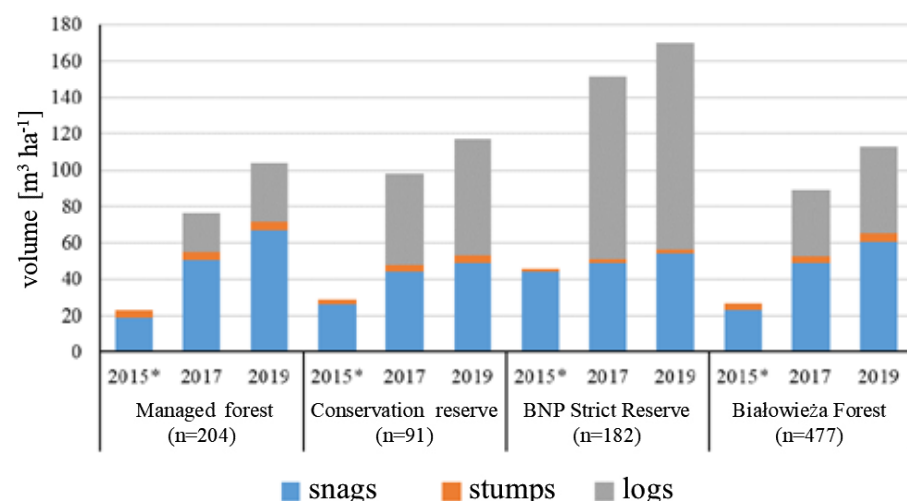

Figure 5.5. Average (area weighted) volume of dead wood in the Polish part of Białowieża Forest in 2015, 2017, and 2019, different conservation categories, * – logs were not considered

Dead wood of all forest-forming tree species growing in the Polish part of Białowieża Forest was found in the study plots. The species structure analysis included 11 species and one combined group including the remaining sparse taxa. Spruce dead wood dominated in the study area and accounted for up to 50% (depending on the measurement year). Standing dead wood, lying dead wood, and stumps show significant increases in the amount of spruce dead wood between measurement dates. The other tree species that influenced the dead wood volume in Białowieża Forest were ash, alder, and oak (Fig. 5.6).

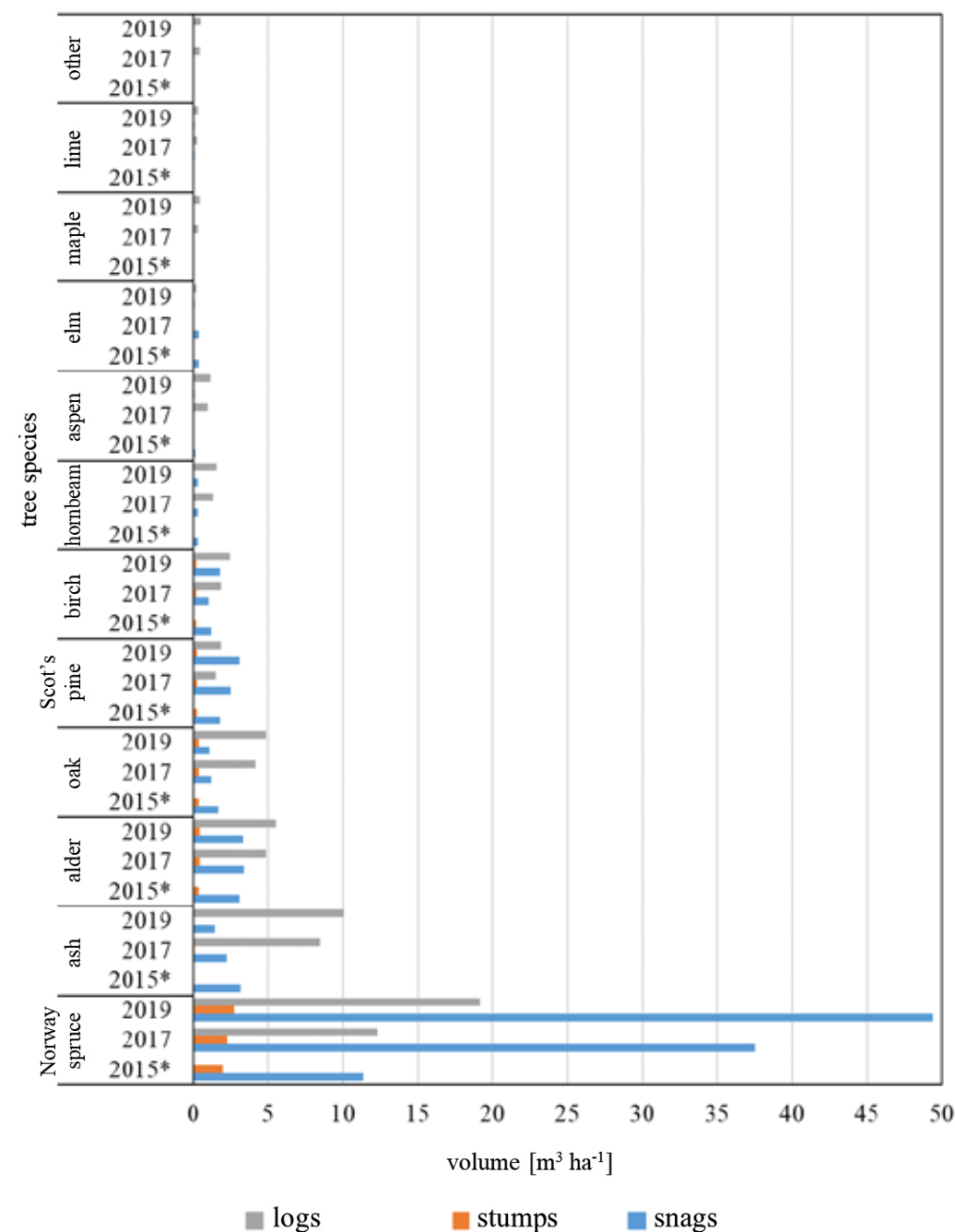

Figure 5.6. Average volume of dead wood in the Polish part of Białowieża Forest in the period 2015–2019 depending on tree species, * – logs were not considered

The proportion of dead wood in various decay classes differed markedly across tree stands with different conservation regimes. In 2019, CWD in the first decay class accounted for more than $\frac{3}{5}$ of the dead wood in managed forests, $\frac{2}{5}$ in conservation reserve, and nearly $\frac{1}{3}$ in the BNP Strict Reserve. This area also had the most balanced proportion of each dead wood decay class (Fig. 5.7).

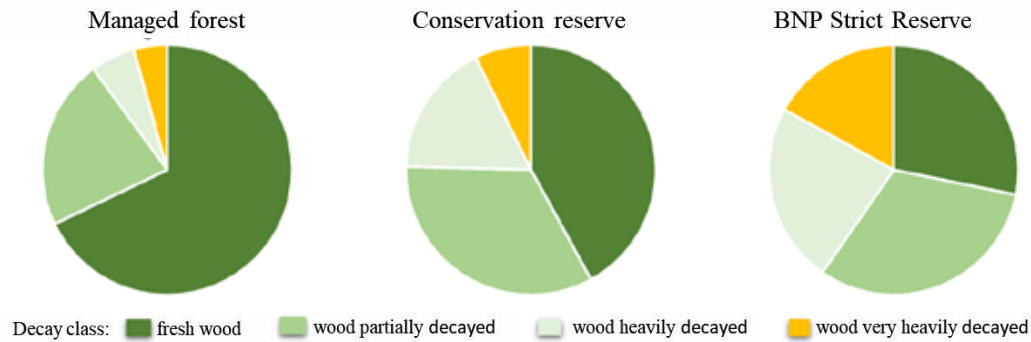

Figure 5.7. Proportion of dead wood decomposition classes in the Polish part of Białowieża Forest in 2019 in three stand conservation categories

The spatial distribution of dead wood in Białowieża Forest also varied markedly (Fig. 5.8). Very high volume of dead wood (exceeding $100 \text{ m}^3 \text{ ha}^{-1}$) with the predominance of lying dead wood was recorded in the BPN Strict Reserve. In the remaining area of Białowieża Forest, the value of $100 \text{ m}^3 \text{ ha}^{-1}$ and higher was recorded less frequently and the dominance of standing dead wood, formed as a result of the recent dieoff of tree stands, was observed. The amount of dead wood below $10 \text{ m}^3 \text{ ha}^{-1}$ was found more often here, but some places, e.g., Szafer Landscape Nature Reserve were rich in dead wood and documented CWD volume $30 \text{ m}^3 \text{ ha}^{-1}$.

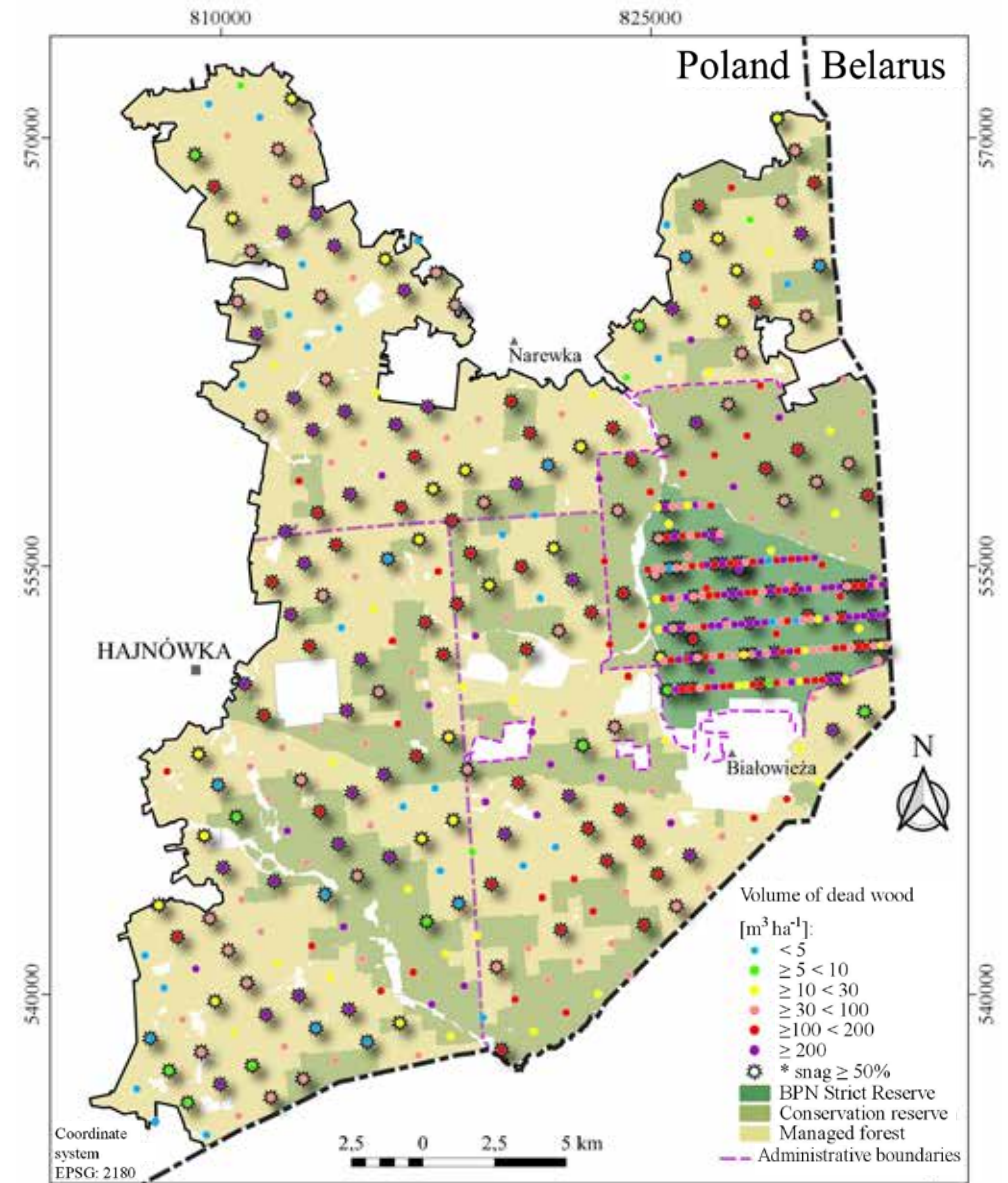

Figure 5.8. Amount of dead wood in the Polish part of Białowieża Forest in 2019

5.4. Discussion

Białowieża Forest is a unique, world-renowned natural site, which has been protected in various ways for about 600 years. The entire forest (Polish and Belarusian parts) has been included into the list of UNESCO Transboundary World Heritage Sites (Jaroszewicz et al. 2019), among others due to the persistence of undisturbed natural processes (Krzyściak-Kosińska et al. 2012). Currently, about 75% of the Polish part of Białowieża Forest is subject to a logging ban (based on data from the Forest Management Plans for 2011–2021 for the Białowieża, Browsk and Hajnówka Forest Districts and Krzyściak-Kosińska et al. 2012). This favours an increase of dead wood resources, as observed in individual measurement years in the period 2015–2019 (Fig. 5.5).

The implementation of the ForBioSensing project coincided with the intensification of environmental changes in Białowieża Forest, related to, inter alia, rising temperatures in recent decades, repeated droughts (Boczoń et al. 2018; see Chapt. 3), the presence of the invasive fungal pathogen *Hymenoscyphus fraxineus* (T. Kowalski) Baral, Queloz, Hosoya, comb. nov. (formerly: *Chalara fraxinea* T. Kowalski) (Kowalski 2006; Baral et al. 2014) responsible for the mass dieback of ash (Jaroszewicz, Cholewińska 2018), significantly high age of many spruce stands and – in particular – with a dynamic development of the spruce bark beetle outbreak, resulting in intense dieback and partial or complete collapse of spruce stands, and thus a rapid increase in the amount of dead wood (Grodzki 2016; Stereńczak et al. 2020). A significant increase in the amount of wood from dead trees is visible, especially in managed forests and in the areas within the conservation reserve category (Fig. 5.5). A relatively small increase in dead wood volume in the area of the BNP Strict Reserve may indicate the dynamic stability of forest ecosystems in this area in comparison with the stands representing the conservation reserve category, and even more so compared to the managed forest category, confirming the results of comparative studies on the mosaic of development phases of lime-oak-hornbeam forests of Białowieża subject to various forms of protection (Bobic et al. 2000). In the context of the difference in the demographic and developmental characteristics of tree stands in the protected and managed areas which was documented in that study, one can argue that a significant decline in the economic pressure in Białowieża Forest at the beginning of the 2010s (Grodzki 2016) initiated ecological processes, one of which is a more dynamic increase in dead wood volume outside the BNP Strict Reserve. On the other hand, the significantly lower increase of dead wood volume in the analysed period inside the BNP Strict Reserve is most likely associated with a much longer history of uncontrolled spruce bark beetle outbreaks in this area, which resulted in large diebacks of spruce, especially at the beginning of the 20th century (Keczyński 2002; Miścicki 2012). Outside of the Białowieża National Park, the sanitary condition of the stands was actively controlled until 2012 (Grodzki 2016).

Białowieża Forest has long been of interest to scientists (Paczoski 1930; Faliński 1986; Bobiec et al. 2005; Jaroszewicz et al. 2019; see Chapt. 2). The first measurements of stand parameters (forest inventory), date back to the mid-19th century (Genko 1902–1903). Nowadays, the first large-scale inventory of dead wood resources in the Polish part of Białowieża Forest was conducted together with the measurements for the Forest Management Plan in 2012. In

turn, the first full-scale inventory of the tree necromass of the entire Polish part of Białowieża Forest, including all forms of nature protection, was carried out within the ForBioSensing project. The innovative aspect of the project was an attempt to determine the short-term dynamics of the amount of dead wood in two-year intervals. The obtained results do not constitute a reliable representation of long-term changes which could not be measured during the ForBioSensing project. The demonstrated significant increase in the volume of dead wood (especially in managed forests and in coniferous and mixed forest habitats) is most likely closely related to the fact that – as already mentioned – the research coincided with the exceptional intensification of the spruce bark beetle outbreak, which accelerated the dieback of spruce stands (Gutowski and Jaroszewicz 2016; Grodzki 2016; Brzeziecki et al. 2019; Stereńczak et al. 2020).

The study revealed a very high volume of dead wood in the stands of the Polish part of Białowieża Forest. The total amount of dead wood recorded in the study plot was nearly 530 m³ ha⁻¹ in some cases. Such high values were recorded when whole spruce stands, characterised by very high stand (i.e., wood) volume, died. In Białowieża Forest, a very high amount of dead wood occurred in almost 80% of the study plots, of which about 60% of the plots were characterised by values of dead wood volume above 100 m³ ha⁻¹. These values were most often recorded in the former Strict Reserve of the Białowieża National Park and the stands representing the conservation reserve category. However, it should be noted that similar values were also recorded in the Białowieża National Park 20 years earlier. At that time, in the lime-oak-hornbeam forests of the BNP, the volume of the lying dead trees ranged between 80 and 160 m³ ha⁻¹, reaching the highest values in the terminal phase (240 m³ ha⁻¹). Similar values were recorded in wet riparian habitats – between 110 and 145 m³ ha⁻¹ (Bobic 2002). A noticeable difference between the results presented in this chapter and the data from the above-cited work is the greater share of standing dead wood. The research carried out in the ForBioSensing project showed that standing dead trees currently account for approximately 30% of the total volume of dead wood, and the quoted publication reports the amount of standing dead wood between 3 and 20% (Bobic 2002). This difference may result from both the different measurement methods used and the fact that in the meantime the process of ash dieback has intensified (Jaroszewicz and Cholewińska 2018) and the effect of a new wave of spruce bark beetle outbreak is present, albeit limited in recent years (Stereńczak et al. 2020). The average volume of dead wood in the BNP Strict Reserve, i.e. 167 m³ ha⁻¹, recorded in 2019, is also comparable to the results of Brzeziecki's 2019 inventory (Brzeziecki 2020), where the value of 194.6 m³ ha⁻¹ has been documented. A certain discrepancy in the results, however, may be due to the differences in the methods of the analysis and the fact that the calculations of the dead wood volume were made there without distinguishing between wood in bark and without bark. In this study, analyses were performed for the wood of dead trees without bark (for details see: „Materials and methods”).

In 2019, there was a clear increase in the proportion of study plots with dead wood volume above 100 m³ ha⁻¹ – an increase of approximately 15% over two years. Currently, this share is more than half, which further confirms the progress of dieback of spruce stands in many places in Białowieża Forest. In managed forests, this share is 16%. It is a significant value, more so as such a high volume of dead trees is rarely found in commercially managed stands (Czerepko 2008; Lombardi et al. 2008; Bujoczek et al. 2021; Öder et al. 2021). For

dead wood volume of 30–100 m³ ha⁻¹, changes in the proportion of study plots falling into that class during the study period were small, but it should be emphasised that its share is also significant and currently amounts to approximately 25–30%. In 2015, about 20% of the study plots were characterised by a low amount of dead wood – up to 10 m³ ha⁻¹. Two years later, in 2017, that proportion fell to just 12%. In 2019, the average amount of dead wood (i.e., 10 to 30 m³ ha⁻¹) was found on 8% of the study plots, and the overall proportion of that category also decreased.

This chapter presents the results of dead wood volume inventory based on schematic, circular, and continuous monitoring plots. Circular plots are the most commonly used method for surveying dead wood resources (Wolski 2002; 2003; Bujoczek 2015). While simple, this method is time-consuming and requires a meticulous approach to repeated measurements to properly record the changes over the study period. Another method of dead wood inventory is transect surveys. Unfortunately, on the scale of a single stand, these methods are difficult to compare, as demonstrated by the ForBioSensing project. The results of these methods can effectively be compared only for large spatial units. In previous studies of dead wood in Białowieża Forest, both methods were used (Paluch 2001; Bobiec 2002; Brzeziecki et al. 2010).

There is relatively little data on the amount of dead wood in forests analysed on a large spatial scale. Large-scale measurements of dead wood were carried out several times in Poland (e.g., Czerepko 2008; Stachura-Skierczyńska and Bobiec 2008), and since 2014, the measurement of dead wood has been included in the large-scale the National Forest Inventory (BULiGL 2021). These large-scale inventories show a much larger amount of dead wood in hard-to-reach mountain forests and legally protected areas than in easily available lowland Scots pine monocultures that are commercially managed. This is consistent with

trends observed in other Central European forests (e.g., Winter et al. 2005; Lombardi et al. 2008; Öder et al. 2021), as well as with the results presented in this study, which show the comparable impact of the forest stand protection category on the dead wood volume (Fig. 5.5).

Dead wood does not appear evenly distributed in the forest. The scale of the appearance of dead wood can be local – due to the death of one or a few trees – or large-scale – due to the death of entire stands (Miścicki 2016; Hilszczański and Jaworski 2018), as was the case in Białowieża Forest at the beginning of the study period. The occurrence of dead wood in a given area depends on the species composition of the stands, the form of forest management or nature conservation carried out, the dominant species, and many other factors. This is confirmed by our research, in which the variability in the amount of dead wood in the studied areas is very high (Fig. 5.8), which reflects the complex structure and species composition of Białowieża Forest. Bobiec (2002) emphasises the impact of historical factors (i.e., dead wood as an element of a specific „ecological memory” of a forest ecosystem) on the structure of dead wood resources. In this study, the amount of dead wood was mainly the result of the spruce bark beetle outbreak (lasting since 2012) (Grodzki 2016; Stereńczak et al. 2020). However, this outbreak and its effects can also be interpreted as a phenomenon related to much earlier processes, such as the introduction of fire protection in the 19th century, which led to the disappearance of forest fires previously present in Białowieża Forest, and resulted in the expansion of spruce, especially in coniferous forests (Niklasson et al. 2010; Bobiec 2012). Due to the multitude of factors determining the volume of dead trees and its dynamics in such a diverse (both in terms of habitats and in terms of the management and protection of tree stands) and vast forest area as Białowieża Forest, it is worth emphasising the value and the need to continue the inventory of such a key environmental parameter which is dead wood.

5.5. Summary

Recently (in the 20th century) Białowieża Forest has seen a historically significant (Stereńczak et al. 2020) increase in the supply of dead wood, especially spruce dead wood (Fig. 5.10). Currently (in 2019), over 75% of the monitoring plots used in this study are characterised by a high or very high amount of dead wood, with values above 100 m³ ha⁻¹ subsequently occurring on an increasing number of study plots. This is further confirmed by complementary data on a significant increase (between 2015 and 2019) in the number of sample plots where the terminal phases of Białowieża Forest stands have been identified (see Chapt. 4).

The data collected within the ForBioSensing project on the status and short-term dynamics of the dead wood volume are exceptionally comprehensive and collected with high frequency, allowing for a very detailed characterization of this environmental parameter and possibly forming a baseline for future analyses of dead wood dynamics in the Polish part of Białowieża Forest.



Figure 5.9. Dead standing oak in Białowieża Forest (photo L. Kuberski, autumn 2020)



Figure 5.10. Dead spruce stand in Białowieża Forest (photo L. Kuberski, summer 2016)

Acknowledgments

The authors would like to thank those involved in different stages of dead wood inventory in the Polish part of Białowieża Forest at various stages of the ForBioSensing project. First and foremost, to Prof. Stanisław Miścicki for his support in the analysis. We thank the following individuals for their assistance with field data collection and database development and updating efforts during 2015–2019: Michał Androsiuk, Kazimierz Borowski, Kamil Pilch, Karol Rzeczycki, Paweł Sańczyk, Adam Szulc, Krzysztof Szyłak and many other unnamed collaborators and volunteers.

References

- Baral H.-O., Queloz V., Hosoya T. 2014. *Hymenoscyphus fraxineus*, the correct scientific name for the fungus causing ash dieback in Europe. *IMA Fungus* 5: 79–80. DOI: 10.5598/imafungus.2014.05.01.09.
- Blanco J.A., Lo Y. 2012. Forest Ecosystems - More than Just Trees. *Deadwood in Forest Ecosystems*. DOI: 10.5772/1127.
- Bobiec A. 2002. Living stands and dead wood in the Białowieża Forest: suggestions for restoration management. *Forest Ecology and Management*, 165: 121–136. DOI: 10.1016/S0378-1127(01)00655-7.
- Bobiec A., Gutowski J.M., Zub K., Pawlaczyk P., Laudenslayer W.F. 2005. *The Afterlife of a Tree*. WWF Poland.
- Bobiec A., Jaszcz E., Wojtunik K. 2011. Oak (*Quercus robur* L.) regeneration as a response to natural dynamics of stands in European hemiboreal zone. *European Journal of Forest Research*, 130: 785–797. DOI: 10.1007/s10342-010-0471-3.
- Bobiec A. 2012. Białowieża Primeval Forest as a remnant of culturally modified ancient forest. *European Journal of Forest Research*, 131: 1269–1285. DOI: 10.1007/s10342-012-0597-6.
- Boczoń A., Kowalska A., Ksepko M., Sokołowski K. 2018. Climate Warming and Drought in the Białowieża Forest from 1950–2015 and Their Impact on the Dieback of Norway Spruce Stands. *Water* 10, 1502. DOI: 10.3390/w10111502.
- Bruchwald A., Rymer-Dudzińska T., Dudek A., Michalak K., Wróblewski L., Zasada M. 2000. Wzory empiryczne do określania wysokości i pierśnicowej liczby kształtu grubizny drzewa. *Sylwan*, 144(10): 5–13.
- Brzeziecki B., Keczyński A., Zajączkowski J., Drozdowski S., Gawron L., Buraczyk W., Bielak K., Szeligowski H., Dzwonkowski M., Ostrowski J., Widawska Z. 2010. *Operat dynamiki ekosystemów leśnych Białowieskiego Parku Narodowego. Maszynopis w Katedrze Hodowli Lasu SGGW, Warszawa.*
- Brzeziecki B., Andrzejczyk, T., Żybura H. 2018. Natural regeneration of trees in the Białowieża Forest. *Sylwan*, 162(11): 883–896. DOI: 10.26202/sylwan.2018116.
- Brzeziecki B., Zajączkowski J., Bolibok L. 2019. *Gatunki drzew i drzewostany <Puszczy Białowieskiej>. Maszynopis w Katedrze Hodowli Lasu, Szkoła Główna Gospodarstwa Wiejskiego.*
- Brzeziecki B. 2020. *Sprawozdanie roczne z tematu: „Analiza aktualnych parametrów populacyjnych oraz trendów demograficznych gatunków drzew w Puszczy Białowieskiej”. Generalna Dyrekcja Lasów Państwowych.*
- Bujoczek L. 2012. Decomposition of coarse woody debris in forest ecosystems with particular reference to spruce, beech and fir. *Sylwan*, 156(3): 208–217. DOI: 10.26202/sylwan.2011071.

- Bujoczek L. 2015. Measurement and calculation of the volume of deadwood on circular sampling plots. *Sylwan*, 159(10): 795–803. DOI: 10.26202/sylwan.2015027.
- Bujoczek L., Bujoczek M., Zięba S. 2021. How much, why and where? Deadwood in forest ecosystems: The case of Poland, *Ecological Indicators*, 121. DOI: 10.1016/j.ecolind.2020.107027.
- BULiGL 2021. The National Forest Inventory. Results of cycle III (2015–2019).
- Byk A. 2001. Próba waloryzacji drzewostanów starszych klas wieku Puszczy Białowieskiej na podstawie struktury zgrupowań chrząszczy (Coleoptera) związanych z rozkładającym się drewnem pni martwych drzew stojących i dziupli. In: Szujecki A. (Edi.) *Próba szacunkowej waloryzacji lasów Puszczy Białowieskiej metodą zooindykacyjną*. Publisher SGGW, Warszawa, s. 333–367.
- Czerepko J. (Edi.) 2008. Stan różnorodności biologicznej lasów w Polsce na podstawie powierzchni obserwacyjnych monitoringu synteza wyników uzyskanych w ramach realizacji projektu BioSoil Forest Biodiversity. Sękocin Stary: Instytut Badawczy Leśnictwa.
- Faliński J.B. 1978. Uprooted trees, their distribution and influence in the primeval forest biotope. *Vegetatio*, 38: 175–183.
- Faliński J.B. 1986. Vegetation dynamics in temperate lowland primeval forest. *Ecological studies in Białowieża Forest*. In: Junk. Dordrecht.
- Franklin J.F., Cromack K., Denison W., McKee A., Maser Ch., Sedell J., Swanson F. Juday F. 1981. Ecological characteristics of old-growth Douglas-fir forests. U.S. Department of Agriculture, Forest Service, Pacific Northwest Research Station. DOI: 10.2737/PNW-GTR-118.
- Genko N. 1902–1903. Charakteristika Belovezhskoi pushchi i istoricheskaya o nei dannyya. *Lesnoi Zhurnal*, 32; 33: 1012–1056, 1269–1302; 1022–1056.
- Grodzki W. 2016. Mass outbreaks of the spruce bark beetle *Ips typographus* in the context of the controversies around the Białowieża Primeval Forest. *Forest Research Papers*, 77(4): 324–331. DOI: 10.1515/frp-2016-0033.
- Gutowski J.M., Sućko K., Zub K., Bohdan A., Aukema B. 2014. Habitat preferences of *Boros schneideri* (Coleoptera: Boridae) in the natural tree stands of the Białowieża Forest. *Journal of Insect Science*, 14(1). DOI: 10.1093/jisesa/ieu138.
- Gutowski J.M., Jaroszewicz B. 2016. Zmiany udziału świerka pospolitego w drzewostanach Puszczy Białowieskiej w kontekście dynamiki liczebności kornika drukarza *Ips typographus* (L.). [In:] *Stan ekosystemów leśnych Puszczy Białowieskiej*: 87–108. CILP.
- Harmon M.E., Franklin J.F., Swanson F.J., Sollins P., Gregory S.V., Lattin J.D., Anderson N.H., Cline S.P., Aumen N.G., Sedell J.R., Lienkaemper G.W., Cromack K., Cummins K.W. 1986. Ecology of Coarse Woody Debris in Temperate Ecosystems. *Advances in Ecological Research*, 15: 133–302. DOI: 10.1016/S0065-2504(03)34002-4.
- Hilszczański J., Jaworski T. 2018. Biodiversity conservation in the białowieża forest in the context of natural and anthropogenic disturbances dynamics. *Sylwan*, 162(11): 927–932. DOI: 10.26202/sylwan.2018137.
- Jaroszewicz B., Cholewińska O. 2018. European ash (*Fraxinus excelsior* L.) dieback in a core area of Białowieża National Park, *National Parks and Nature Reserves*, 37(2): 3–18.
- Jaroszewicz B., Cholewińska O., Gutowski J.M., Samojlik T., Zimny M., Latałowa M. 2019. Białowieża Forest—A Relic of the High Naturalness of European Forests. *Forests*, 10, 849. DOI: 10.3390/f10100849.
- Keczyński A. 2002. Wpływ gradacji kornika drukarza na drzewostany Obszaru Ochrony Ścisłej Białowieskiego Parku Narodowego. *Kosmos*, 51(4): 471–474.
- Kowalski T. 2006. *Chalara fraxinea* sp. nov. associated with dieback of ash (*Fraxinus excelsior*) in Poland. *Forest Pathology*. 36: 264–270. DOI: 10.1111/j.1439-0329.2006.00453.x.
- Krzyściak-Kosińska R., Arnolbik V., Antczak A. 2012. “Belovezhskaya Pushcha/Białowieża Forest” World Heritage Site (33 BIS). Proposed Modification of the Criteria and Boundaries, Change of the Name of the Property. Nomination Dossier to the UNESCO for the Inscription on the World Heritage List. <https://whc.unesco.org/en/list/33/documents/>.
- Lofroth E. 1998. The dead wood cycle. [In:] Voller, J. and Harrison, S. (red.) *Conservation biology principles for forested landscapes*. UBC Press: 185–214.
- Lombardi F., Lasserre B., Tognetti R., Marchetti M. 2008. Deadwood in relation to stand management and forest type in Central Apennines (Molise, Italy). *Ecosystems*, 11: 882–894. DOI: 10.1007/s10021-008-9167-7.
- Maser C., Tarrant R.F., Trappe J.M., and Franklin J.F. 1988. From the Forest to the Sea : A Story of Fallen Trees. U.S. Department of Agriculture, Forest Service, Pacific Northwest Research Station. s. 153. DOI: 10.2737/PNW-GTR-229.
- Miścicki S. 2012. Structure and dynamics of temperate lowland natural forest in the Białowieża National Park, Poland, *Forestry. An International Journal of Forest Research*, 85(4): 473–483. DOI: 10.1093/forestry/cps044.
- Miścicki S. 2016. Changes in the stands of the Białowieża National Park from 2000. *Forest Research Papers*, 77(4): 371–379. DOI: 10.1515/frp-2016-0038.
- Niklasson M., Zin E., Zielonka T., Feijen M., Korczyk A., Churski M., Samojlik T., Jędrzejewska B., Gutowski J.M., Brzeziecki, B. 2010. A 350-year tree-ring fire record from Białowieża Primeval Forest, Poland: Implications for Central European lowland fire history. *Journal of Ecology*, 98:1319–1329. DOI: 10.1111/j.1365-2745.2010.01710.x.
- Öder V., Petritan A.M., Schellenberg J., Bergmeier E., Walentowski H. 2021. Patterns and drivers of deadwood quantity and variation in mid-latitude deciduous forests. *Forest Ecology and Management*, 487. 118977, DOI: 10.1016/j.foreco.2021.118977.
- Paczoski J. 1930. *Forests of Białowieża*. PROP. Poznań.

- Paluch R. 2001. Impact of dead wood on soil fertility determined by vegetation ground cover in Białowieża National Park. *National Parks and Nature Reserves*, 20(4): 15–25.
- Paluch R. 2015. Long-term changes of tree species composition in natural stands of the Białowieża Forest. *Sylwan*, 159(4): 278–288.
- Pawlaczyk P. 2017. Deadwood as an element of the river ecosystem. *Przegląd Przyrodniczy*, 28(4): 62–92.
- Pawlik Ł. 2013. Tree uprooting process and its implications in biomechanical slope cover and slope microrelief disturbances in the upper forest zone of the Polish Karkonosze Mts. *Geographical Studies*, 135: 41–56. DOI: 10.4467/20833113pg.13.022.1550.
- Pyle C., Brown M.M. 1998. A Rapid System of Decay Classification for Hardwood Logs of the Eastern Deciduous Forest Floor. *Journal of the Torrey Botanical Society*, 125(3), s. 237–245. DOI: 10.2307/2997221.
- Stachura-Skierczyńska K., Bobiec A. 2008. Raport – stare drzewa i martwe drewno w polskich lasach. OTOP, Warszawa.
- Stokland J.N., Siitonen J., Jonsson B.G. 2012. Biodiversity in dead wood, *Biodiversity in Dead Wood*, Cambridge University Press.
- Smit C., Kuijper D.P.J., Prentice D., Wassen M.J., Cromsigt J.P.G.M. 2012. Coarse woody debris facilitates oak recruitment in Białowieża Primeval Forest, Poland. *Forest Ecology and Management* 284: 133–141. DOI: 10.1016/j.foreco.2012.07.052.
- Stereńczak K., Mielcarek M., Kamińska A., Kraszewskie B., Piasecka Ż., Miścicki S., Heurich M. 2020. Influence of selected habitat and stand factors on bark beetle *Ips typographus* (L.) outbreak in the Białowieża Forest. *Forest Ecology and Management*, 459, 117826. DOI: 10.1016/j.foreco.2019.117826.
- Wierzcholska S., Dyderski M.K., Pielech R., Gazda A., Smoczyk M., Malicki M., Horodecki P., Kamczyc J., Skorupski M., Hachułk M., Kałucka I., Jagodziński A.M. 2018. Natural forest remnants as refugia for bryophyte diversity in a transformed mountain river valley landscape. *Science of The Total Environment*, 640–641: 954–964. DOI: 10.1016/j.scitotenv.2018.05.340.
- Winter S., Flade M., Schumacher H., Kerstan E., Möller G. 2005. The importance of near natural stand structures for the biocoenosis of lowland beech forests. *Forest Snow and Landscape Research*, 79(1–2): 127–144.
- Wolski J. 2002. Measurements of downed dead wood in the forest - theoretical assumptions and course of field work. *Prace Instytutu Badawczego Leśnictwa–Seria A*, 2(932): 27–45.
- Wolski J. 2003. Down dead wood in the forest: quantification and proposals for handling. *Prace Instytutu Badawczego Leśnictwa, Seria A*, 953(2): 23–45.
- Zielonka T., Ciapała Sz., Malina P., Piątek G. 2009. Coarse woody debris in mountain streams and their influence on geomorphology of channels in the Tatra Mts. *Landform Analysis*. 10. 134–139.

6. Tree regeneration in canopy gaps in Białowieża Forest

Dorota Dobrowolska¹, Łukasz Kuberski², Żaneta Piasecka³, Krzysztof Stereńczak³

¹ Forest Research Institute, Department of Forest Ecology, Sękocin Stary, 3 Braci Leśnej St., 05-090 Raszyn

² Forest Research Institute, Department of Natural Forests, 6 Park Dyrekcyjny St., 17-230 Białowieża

³ Forest Research Institute, Department of Geomatics, Sękocin Stary, 3 Braci Leśnej St., 05-090 Raszyn {d.dobrowolska, l.kuberski, z.piasecka, k.stereńczak}@ibles.waw.pl

Abstract

Forest gaps are an immanent part of forest ecosystems. They are formed as a result of the death of individual trees or groups of trees due to various factors of natural or anthropogenic origin. The objective of this study was to determine the extent to which gaps were colonized during the early-stage regeneration (regeneration height was less than 2 m) as a function of gap origin, forest conservation type, and habitat. The research was carried out in the whole area of the Polish part of Białowieża Forest. Canopy gaps were generated from airborne laser scanning data and then 313 study plots (gaps) were randomly selected for field measurements. All forest-forming species occurring in Białowieża Forest early-stage have regenerated in the gaps. Regeneration numbers varied widely across the gaps. Most tree species were characterised by lack of regeneration in gaps (at least 75% of gaps). Gaps of natural origin predominated among the study plots analysed (54% of gaps). The presence of regeneration in gaps depended on habitat, conservation form, and origin. Gaps favoured regeneration of both deciduous and coniferous species, although deciduous trees regenerated more often. Hornbeam was the dominant species in the gap's regeneration layer, especially in deciduous habitats. Spruce regenerated in gaps especially in moist habitats. Reserve forests had a higher proportion of hornbeam in gaps than managed forests. In contrast, Conservation Reserve, birch, linden, and oak regeneration was favoured in the gaps. Comparing regeneration in gaps and under the stand canopy will provide an in-depth understanding of the role of gaps in regeneration in Białowieża Forest.

Keywords: airborne laser scanning, gaps, forest regeneration

6.1. Introduction

Gaps form in all forests as a result of natural factors (insects, fungi, wind, ice, or fire) or as a result of cutting individual or groups of trees in managed forests (Kern et al. 2017). The regeneration process in gaps depends on many biological and physical factors, including density of stands, tree height, and the presence of regeneration prior to the disturbance (Martins and Rodrigues 2002; Sapkota et al. 2009), stand area (Runkle 1992), and habitat (Zhu et al. 2014). Not only gap size, but also disturbance intensity or spatial and temporal variation in gaps affect regeneration structure and species composition (Sapkota et al. 2009). The size of the gap determines the most important factors affecting regeneration, such as light, air and soil

temperature, and relative air and soil moisture (Martins and Rodrigues 2002). The appearance of pioneer or shade-tolerant species depends on the gap area (Spies et al. 1990). Regeneration in large gaps is characterized by a higher proportion of ruderal species that prevent the development of other species (Kern et al. 2013). Browsing by herbivores can negatively affect regeneration development, despite favourable light conditions in gaps (Kern et al. 2013). Another factor shaping regeneration in gaps is the presence of shrubs (Montgomery et al. 2010).

Disturbances are the most important factor influencing forest ecosystem functioning (Turner 2010). The disturbance regime is subjected to changes due to changing climatic conditions. Increasingly frequent and prolonged periods of drought (Millar and Stephenson 2015), bark beetle outbreaks (Raffa et al. 2008) or fires (Stephens et al. 2014) are affecting forest ecosystems worldwide (Seidl et al. 2017). Białowieża Forest is also subject to various small- and large-scale spatial disturbances. Recently, one of the most significant disturbances in Białowieża Forest has been the bark beetle outbreak, which has been ongoing since 2012 and was particularly exacerbated in 2015 due to warm winters and summer drought (Bobiec et al. 2011a; Grodzki 2016). Not only single spruces or groups of trees are dying, but whole parts of forest, creating a specific mosaic of stands. Quantifying the pattern of disturbances (size, shape, predominant type of disturbance) as well as learning about the factors that influence disturbances is an important research problem.

Previous studies of gap dynamics have focused on natural gaps (Runkle 1992; Sapkota et al. 2009) or resulting from logging (Montgomery et al. 2010). In contrast, there are few studies that consider both types of gaps (natural and artificial) (Bobiec 2007). The main objective of the research presented in this chapter was to determine the extent to which gaps were colonized by early-stage regeneration (regeneration height <2 m) as a function of gap origin, forest conservation type, and habitat. The study verified the following hypotheses: H1 – Hornbeam is the most frequently regenerating species in gaps; H2 – spruce regenerates in gaps significantly less often than thermophilus species (hornbeam, linden), regardless of the stand type; H3 – The form of protection affects the abundance of regeneration in gaps.

6.2. Materials and Methods

6.2.1. Study area

Białowieża Forest covers an area of approximately 620 km² on Polish territory. The study covered the entire area of the Polish part of Białowieża Forest (Fig. 6.1), which is dominated by deciduous and mixed forests, often of natural origin, with a diversified species and age structure. They are mostly overgrown by fertile brown and grey-brown soils (dominated by fresh mixed forest (FMF), fresh forest (FF), and wet deciduous forest (WF)), and in river valleys and in places of former raised bogs – by formations of organic origin (Więcko 1984). The dominant tree species are Norway spruce (*Picea abies* (L.) Karst) – 26%, Scots pine (*Pinus sylvestris* L.) – 24%, black alder (*Alnus glutinosa* Gaertn.) – 17%, oak (*Quercus* L.) – 12% and birch (*Betula* L.) – 11%. Over 40% of the study area is covered by stands over 80 years old (Stereńczak et al. 2017). An area of approximately 105 km² is occupied by Białowieża National Park together with the oldest protective zone, the so-called Strict Reserve (RŚ). Nature Reserves (RP) of varying conservation status and year of establishment cover an area

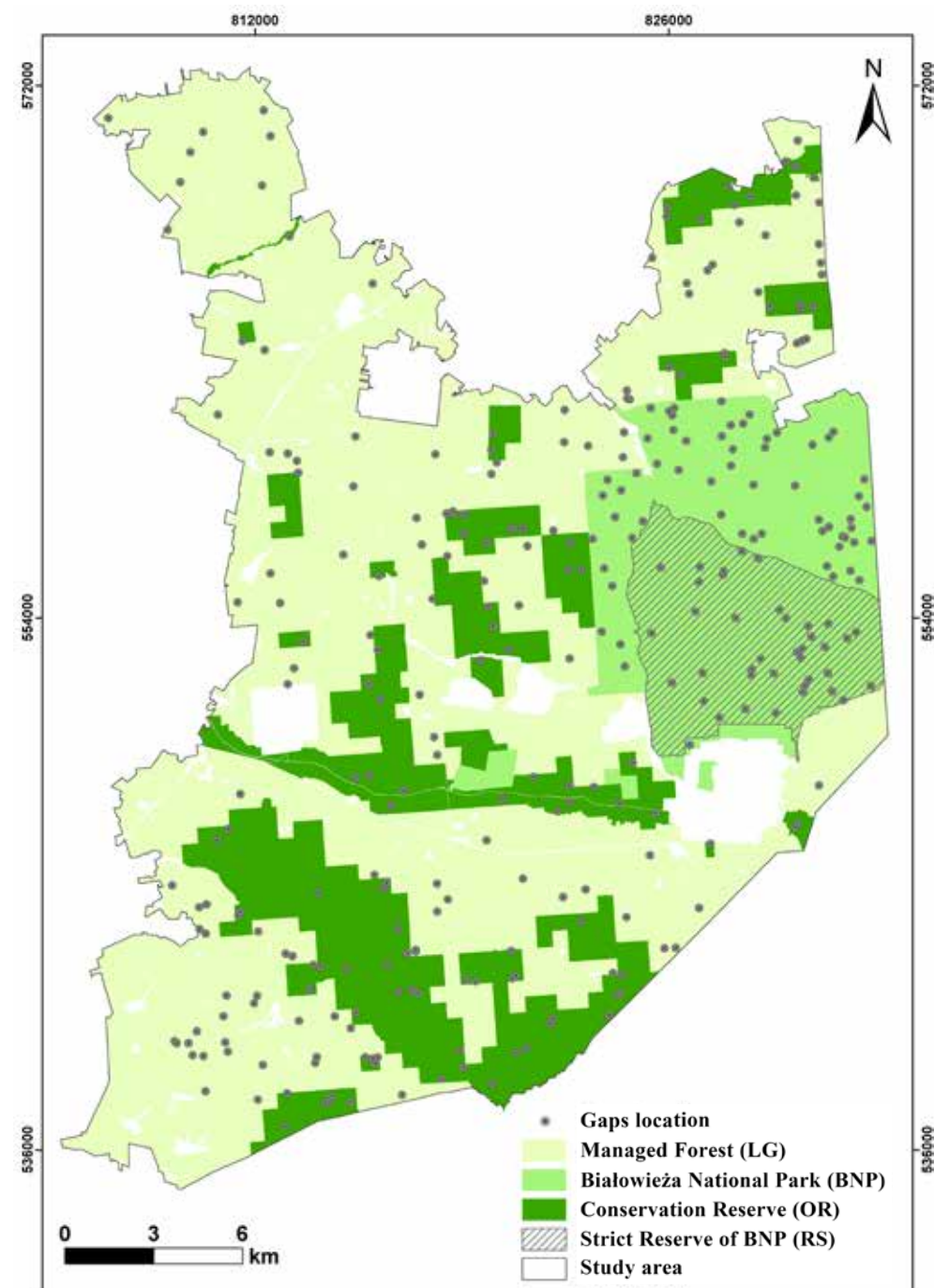

Figure 6.1. Study area and location of gaps in the Polish part of the Białowieża Forest

of about 120 km². The remaining part, about 395 km², consists of managed forests (LG) with different intensity of use managed by three forest districts: Browsk, Hajnówka, and Białowieża (Wesołowski et al. 2016). The area of Białowieża Forest is characterized by low diversified relief. The absolute altitude ranges from 131-196 m. The climate is continental with an influence of the Atlantic climate. The multi-year average (study period 1950–2001) annual temperature is 6.8°C and average annual precipitation is 633 mm (Pierzgalski et al. 2012).

6.2.2. Field research

Based on Airborne Laser Scanning (ALS) data, over two million objects representing gaps in the stand were generated. A gap was defined as an area with a vegetation height of no more than 2 m and an area of no less than 20 m². From the generated polygons, test sites were randomly selected for field measurements. The study used measurement data from 313 study plots. The criteria for selecting the gaps were their area and form of protection. In each gap, concentric circular surfaces with different radii were assumed at the centre point (surface centroid). Depending on the radius, the different stages of regeneration were measured. In a 1.3 m (5.3 m²) radius plot, regeneration ranging from 2 years to 30 cm in height (seedlings) was measured. In an area with a radius of 2.52 m (20 m²), regeneration with a height greater

than 30 cm and a diameter at breast height up to 2 cm (small saplings) was measured. In an area with a radius of 3.99 m (50 m²), regeneration with a diameter at breast height of 2 to 7 cm (tall saplings) was measured. For each individual regeneration, the species was determined and the height and diameter at breast height (for trees over 1.3 m in height) were measured. In addition, the forest habitat type was determined from the habitat map, the age of the gap, its origin (natural vs artificial), and its form of protection. The gaps were divided into three groups depending on the form of protection: Strict Reserve of Białowieża National Park (area excluded from use since 1921) - RS, managed forests - LG and conservation reserve - OR (nature reserves plus part incorporated into Białowieża National Park after 1996), and into four groups with regard to habitat: 1) coniferous forests, 2) bog coniferous and deciduous forests, 3) deciduous forests, and 4) alder bog forests and riparian forests. Field studies were conducted in 2016–2018 during the full growing season (Fig. 6.2).

6.2.3. Statistical analysis

For the most abundant regenerating tree species/types (spruce, pine, birch, oak, hornbeam (*Carpinus betulus* L.), Norway maple (*Acer platanoides* L.), small-leaved lime (*Tilia cordata* Mill.), the mean regeneration density values, median and standard deviation are summarized in table. A Kruskal-Wallis test was conducted to check statistically significant differences between groups of individual variables (habitat group, conservation form, gap origin) in the occurrence of restoration. Interpretation of the results depends on the p value: $p < 0.05$ – significant differences between groups, $p > 0.05$ – non-significant differences between groups. A statistically significant test result only indicates that at least one of the studied groups is different from another. Therefore, when significant differences were found between the study groups, *post-hoc* analysis was performed to identify groups that were statistically significantly different. During *post-hoc* analysis, a nonparametric Mann-Whitney and Wilcoxon test was performed for each pair of groups. A non-parametric χ^2 test was used to assess the relationship of the occurrence (presence or absence) of regeneration in gaps to habitat type, conservation form, and gap origin. This test considered two hypotheses: H0, where $p > 0.05$ indicates that there is no evidence of a relationship between the variables (in the case under consideration, this means that the variables are independent and the variable does not affect the presence of regeneration). H1, where $p < 0.05$ indicates that the variables are dependent on each other (the variable affects the presence of regeneration). For the test, regeneration abundance was changed to a dichotomous variable (presence/absence). The test was performed for 7 species at each stage of recovery and three independent variables. All analyses were performed in the R programme.

6.3. Results

6.3.1. Regeneration in the gaps

The main species that regenerated in the gaps was hornbeam (Fig. 6.3), whose proportion (38%) was almost twice that of spruce (21%) (Fig. 6.4). The proportion of birch in the regeneration was 14% and the other species were less than 10% (regeneration of maple, oak, rowan and lime). The presence of 13 tree species/genera was recorded in the seedlings phase,



Figure 6.2. Field data collection at one of the designated gaps in Białowieża Forest (photo by K. Rzczycki)

15 in the small saplings phase, and 9 in the tall saplings phase. All forest-forming species occurring in Białowieża Forest have regenerated in the gaps (Fig. 6.3).

6.3.2. Gap origin vs regeneration abundance

Regeneration density varied widely across the gaps. Most species were characterized by a lack of regeneration in gaps (at least 75% of gaps). In a few cases, the median >0, indicating that the species was frequently regenerating (Tab. 6.1).

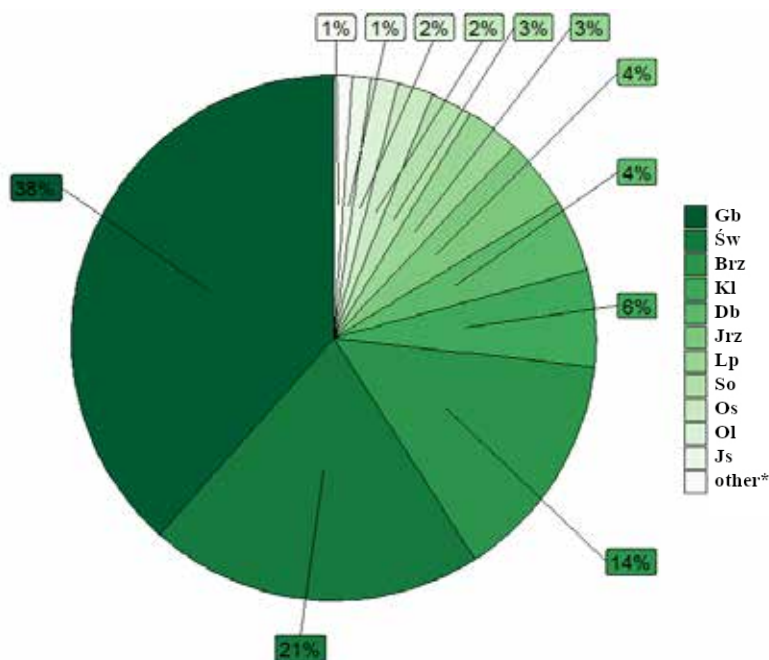

Figure 6.3. The proportion of all species regenerating in gaps in Białowieża Forest. Gb – common hornbeam, Św – Norway spruce, Kl – maple, Db – oak, Jrz – mountain ash, Lp – small-leaved lime, So – Scot’s pine, Os – common aspen, Ol – black alder, Js – common ash, other* – elm, willow, fruit trees, shrubs

Table 6.1. Mean regeneration density (\pm SD) by gap origin

Species	Anthropogenic					
	seedlings		small saplings		tall saplings	
	average	median	average	median	average	median
pine	500 \pm 2212	0	241 \pm 1371	0	0	0
birch*	1145 \pm 6043	0	2586 \pm 5453	501	39 \pm 260	0
oak*	250 \pm 679	0	1069 \pm 1677	501	12 \pm 68	0
hornbeam	2463 \pm 14647	0	5341 \pm 26532	0	19 \pm 130	0

Species	Natural					
	seedlings		small saplings		tall saplings	
	average	median	average	median	average	median
spruce	4254 \pm 19776	0	1724 \pm 6066	0	36 \pm 147	0
maple*	79 \pm 665	0	196 \pm 1164	0	1 \pm 16	0
lime*	79 \pm 439	0	171 \pm 1270	0	1 \pm 16	0
pine	210 \pm 1012	0	41 \pm 227	0	0	0
birch*	432 \pm 2197	0	1179 \pm 4325	0	9 \pm 52	0
oak*	144 \pm 579	0	221 \pm 462	0	2 \pm 21	0
hornbeam	3711 \pm 14322	0	2694 \pm 8625	0	12 \pm 69	0
spruce	886 \pm 2649	0	975 \pm 5510	0	44 \pm 169	0
maple*	1340 \pm 5476	0	451 \pm 1701	0	0	0
lime*	531 \pm 5839	0	365 \pm 2702	0	5 \pm 33	0

* pedunculate oak, silver birch and downy birch, Norway maple, small-leaved lime



Figure 6.4. Spruce regeneration in one of the gaps in Białowieża Forest (photo Ł. Kuberski)

Gaps of natural origin predominated among the study plots analysed, accounting for 54%. The origin of the gap had a significant effect on the presence of maple seedlings (Chi^2 test $p < 0.01$) (Tab. 6.2). Spruce regenerated most often in gaps of anthropogenic origin, especially in coniferous and deciduous forest habitats. Pine and birch were also more common in the seedlings layer in gaps of anthropogenic origin in coniferous and deciduous forest habitats. On the other hand, in natural gaps oak and hornbeam regenerated more often, especially in deciduous forest habitats as well as lime, alder and ash (*Fraxinus excelsior* L.), regardless of the habitat.

Tabela 6.2. Siedlisko, formy ochrony i pochodzenia luki a występowanie odnowienia w lukach (wartości w tabeli oznaczają poziom istotności - test Chi^2)

Species**	habitat	form of protection	origin of the gap
pine seedlings	0.0298	0.4993	0.1317
pine small saplings	0.0061	0.0638	0.3855
pine tall saplings	brak	brak	brak
birch seedlings	0.0740	0.6694	0.2033
birch small saplings	0.0000	0.2604	0.0000
birch tall saplings	0.0787	0.5801	0.1712
oak seedlings	0.0953	0.5817	0.0962
oak small saplings	0.0000	0.0366	0.0000
oak tall saplings	0.3597	0.0444	0.1846
hornbeam seedlings	0.0000	0.0271	0.9311
hornbeam small saplings	0.0000	0.4744	0.0161
hornbeam tall saplings	0.2559	0.7807	1.0000
spruce seedlings	0.0007	0.6209	0.0767
spruce small saplings	0.0000	0.2875	0.0180
spruce tall saplings	0.0000	0.5853	1.0000
maple seedlings	0.0001	0.0023	0.0015
maple small saplings	0.0000	0.1093	0.0245
maple tall saplings	0.8081	0.3963	0.9309
lime seedlings	0.1352	0.0767	0.7921
lime small saplings	0.0002	0.0001	0.2214
lime tall saplings	0.3024	0.0161	0.3044

* values that are bold indicate significant differences

** species designations as in Table 6.1 (pedunculate oak, silver birch and downy birch, Norway maple, small-leaved lime)

In the small saplings layer, hornbeam, oak, pine and birch, and spruce were more likely to regenerate in gaps of anthropogenic origin. Gap origin had a significant effect on the presence of birch, hornbeam, oak, maple, and spruce small saplings (Chi^2 test $p < 0.05$) (Tab. 6.2). The abundance of birch (Fig. 6.5) and oak (Fig. 6.6) saplings was significantly higher in gaps of anthropogenic origin in all habitats except alder and riparian forests (statistically significant differences compared to gaps of natural origin, $p < 0.05$ – Wilcoxon test). Spruce and pine, on the other hand, regenerated mainly in artificial gaps, and also in coniferous forest habitats. In the gaps of natural origin, ash, alder, maple, aspen (*Populus tremula* L.), lime and elm (*Ulmus glabra* Huds.) regenerated more frequently.

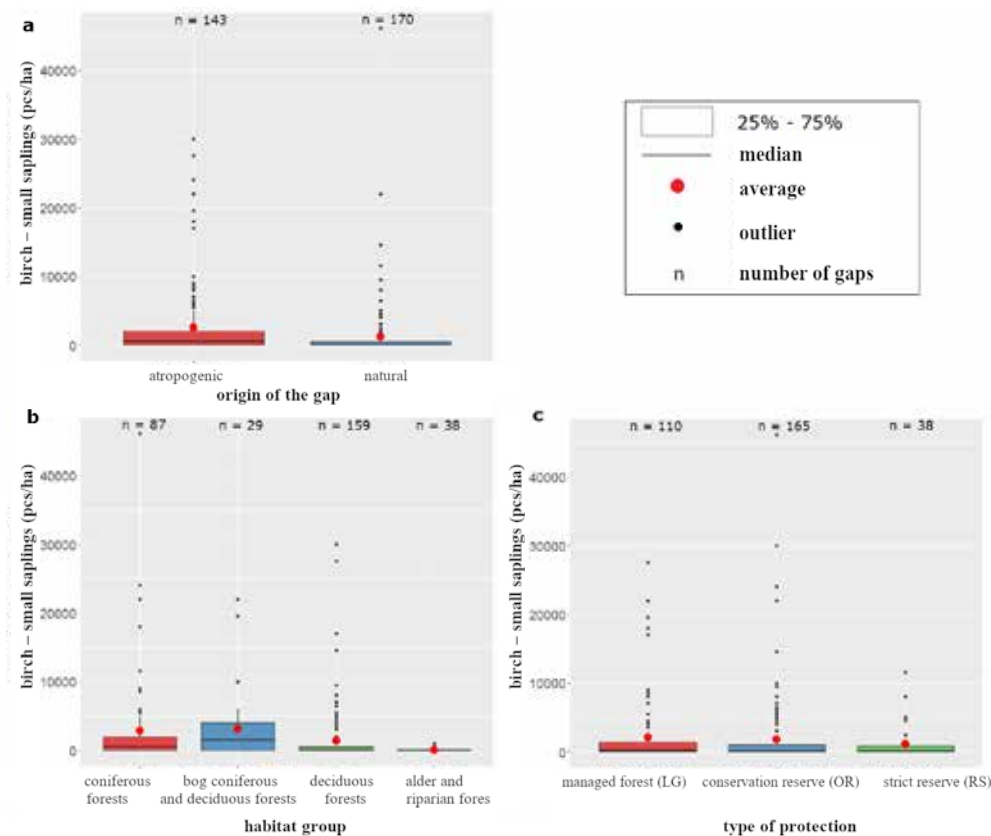

Figure 6.5. Density of birch small saplings in gaps according to gap origin, habitat, and conservation form in Białowieża Forest

In the tall saplings, spruce regenerated in natural gaps in deciduous forest habitats, while in coniferous forest habitats it regenerated more often in gaps of anthropogenic origin. Oak occurred mainly in gaps of anthropogenic origin. Alder saplings were observed primarily in natural gaps in moist habitats (alder and riparian forests). Hornbeam was present in both types of gaps.

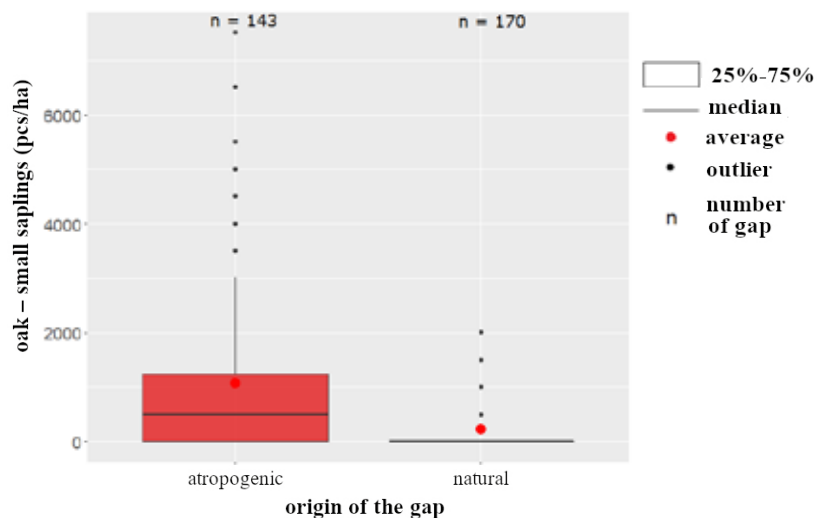

Figure 6.6. The density of oak small saplings in gaps according to the origin of the gap in Białowieża Forest

6.3.3. Regeneration density in gaps depending on habitat

The occurrence of pine, hornbeam, spruce and maple seedlings in gaps was influenced by habitat (Chi^2 test, $p < 0.05$) (Tab. 6.2). Coniferous forest habitats were dominated by pine, birch, and oak seedlings (Fig. 6.3). Figure 6.7 shows an example of oak and hornbeam regeneration in a gap in Białowieża Forest.



Figure 6.7. Oak and hornbeam regeneration in one of the gaps in Białowieża Forest (photo by Ł. Kuberski)

Spruce regenerated in all habitats, although it was most abundant in coniferous forests, and bog coniferous and deciduous forests. Maple, lime, and hornbeam regenerated in gaps in deciduous forest habitats. In contrast, ash and alder primarily occupied gaps in deciduous, alder and riparian forest habitats (Tab. 6.3).

The presence of small saplings of pine, birch, lime, hornbeam, oak, maple, and spruce in the gaps was significantly affected by habitat (Chi^2 test $p < 0.001$) (Tab. 6.2). Hornbeam was dominant in this regeneration phase and was more abundant than in the seedling phase. The average density of small saplings of birch was twice that of hornbeam and spruce. There was a significant abundance of saplings of rowan (*Sorbus aucuparia* L.) and oak. The number of maple, aspen, and lime small saplings was low. Forest habitats were occupied primarily by hornbeam saplings (Fig. 6.8) (statistically significant differences from the other habitat groups, $p < 0.05$ – Wilcoxon test), accompanied by oak, maple, aspen, lime, and elm. Coniferous and bog habitats were dominated by spruce and pine regeneration. Birch saplings were most abundant in bog coniferous and deciduous forest habitats (Fig. 6.5) (statistically significant differences compared to the other habitat groups, $p < 0.05$ – Wilcoxon test). On the other hand, alder and ash were restored in the alder forest habitats.

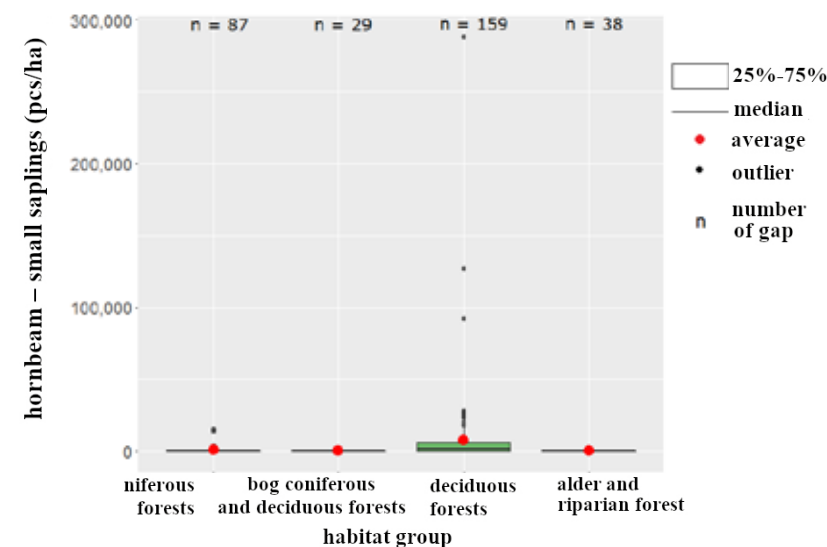

Figure 6.8. Density of small saplings of hornbeam in gaps according to habitat in Białowieża Forest

In described regeneration stages (seedlings, small and tall saplings) the density of tall saplings was the lowest. Regeneration of spruce in gaps depended on habitat (Chi^2 test $p < 0.0001$). Spruce regenerated primarily in bog and coniferous habitats, although it occurred in all habitats, as birch saplings. The density of birch and alder was twice as low as that of spruce. Alder was most abundant in gaps in wet habitats, alder and riparian forest habitats, while hornbeam was most abundant in deciduous forest habitats. Oak saplings were recorded mainly in gaps in the coniferous forest habitats and sparsely in the deciduous forest habitats (Tab. 6.3).

Table 6.3. Mean regeneration density (\pm SD) depending on the habitat

Species	Coniferous forests					
	seedlings		small saplings		tall saplings	
	average	median	average	median	average	median
pine	757 \pm 2806	0	339 \pm 1636	0	0	0
birch	1320 \pm 7198	0	2863 \pm 6693	501	22 \pm 77	0
oak	259 \pm 769	0	599 \pm 1115	0	13 \pm 73	0
hornbeam	368 \pm 2146	0	547 \pm 2254	0	4 \pm 30	0
spruce	4741 \pm 23470	0	2535 \pm 8031	0	78 \pm 203	0
maple	43 \pm 403	0	5 \pm 53	0	0	0
lime	21 \pm 201	0	0	0	0	0
Species	Swampy coniferous forests and swap forests					
	seedlings		small saplings		tall saplings	
	average	median	average	median	average	median
pine	519 \pm 1661	0	138 \pm 462	0	0	0
birch	649 \pm 2210	0	3180 \pm 5435	1503	27 \pm 88	0
oak	64 \pm 349	0	259 \pm 678	0	0	0
hornbeam	0	0	0	0	0	0
spruce	1104 \pm 2688	0	1486 \pm 3008	0	103 \pm 204	0
maple	0	0	0	0	0	0
lime	0	0	0	0	0	0
Species	Forests					
	seedlings		small saplings		tall saplings	
	average	median	average	median	average	median
pine	165 \pm 775	0	50 \pm 485	0	0	0
birch	651 \pm 2974	0	1424 \pm 4031	0	27 \pm 243	0
oak	225 \pm 648	0	819 \pm 1482	0	6 \pm 41	0
hornbeam	5970 \pm 19851	0	7361 \pm 26237	1503	27 \pm 139	0
spruce	1966 \pm 7656	0	926 \pm 5267	0	16 \pm 131	0
maple	1480 \pm 5667	0	655 \pm 2033	0	1 \pm 15	0
lime	627 \pm 6044	0	539 \pm 3023	0	6 \pm 35	0
Species	Alder bog and riparian forests					
	seedlings		small saplings		tall saplings	
	average	median	average	median	average	median
pine	0	0	0	0	0	0
birch	0	0	65 \pm 238	0	0	0
oak	0	0	13 \pm 81	0	0	0
hornbeam	49 \pm 305	0	105 \pm 438	0	5 \pm 32	0
spruce	49 \pm 305	0	39 \pm 136	0	10 \pm 64	0
maple	0	0	0	0	0	0
lime	0	0	26 \pm 113	0	5 \pm 32	0

6.3.4. Regeneration abundance in gaps and form of protection

The presence of maple and oak seedlings in the gaps depended on the form of protection (Chi^2 test $p < 0.05$) (Tab. 6.2). In managed forest, spruce and birch were most likely to regenerate in coniferous forest habitats and pine, especially in bog and deciduous forest habitats. In the reserve forests, oak, hornbeam, spruce, and maple were present in the seedlings phase. On the other hand, in the Strict Reserve, not only pine, spruce and birch seedlings were found, but also maple and lime and hornbeam seedlings, especially in deciduous forest habitats (Tab. 6.4).

Table 6.4. Mean regeneration density (\pm SD) depending on conservation form

Species	Managed forest (LG)					
	seedlings		small saplings		tall saplings	
	average	median	average	median	average	median
pine	393 \pm 1376	0	318 \pm 1562	0	0	0
birch	1112 \pm 6560	0	2077 \pm 5002	250	41 \pm 293	0
oak	222 \pm 661	0	1025 \pm 1722	0	16 \pm 77	0
hornbeam	1455 \pm 8773	0	3280 \pm 15287	0	18 \pm 136	0
spruce	4297 \pm 21974	0	1786 \pm 6770	0	45 \pm 170	0
maple	547 \pm 4552	0	236 \pm 1157	0	1 \pm 19	0
lime	0	0	45 \pm 230	0	1 \pm 19	0
Species	Conservation reserve (OR)					
	seedlings		small saplings		tall saplings	
	average	median	average	median	average	median
pine	353 \pm 1990	0	39 \pm 207	0	0	0
birch	536 \pm 2621	0	1813 \pm 5277	0	10 \pm 55	0
oak	194 \pm 645	0	419 \pm 891	0	1 \pm 15	0
hornbeam	3002 \pm 14789	0	4231 \pm 22838	0	15 \pm 79	0
spruce	1575 \pm 5079	0	1278 \pm 5697	0	43 \pm 166	0
maple	605 \pm 3056	0	385 \pm 1706	0	0	0
lime	91 \pm 455	0	145 \pm 1178	0	2 \pm 21	0
Species	Strict Reserve (RS)					
	seedlings		small saplings		tall saplings	
	average	median	average	median	average	median
pine	148 \pm 675	0	0	0	0	0
birch	693 \pm 2334	0	1121 \pm 2428	0	21 \pm 77	0
oak	99 \pm 426	0	224 \pm 446	0	5 \pm 32	0
hornbeam	8624 \pm 22978	0	4286 \pm 7353	0	10 \pm 64	0
spruce	693 \pm 1827	0	131 \pm 301	0	15 \pm 71	0
maple	2081 \pm 6127	0	395 \pm 1288	0	0	0
lime	2280 \pm 12309	0	1516 \pm 5613	0	15 \pm 54	0

The effect of protection form on the presence of small saplings in gaps was found for lime and oak (Chi^2 test $p < 0.05$) (Tab. 6.2). In managed forests, regenerating was primarily pine in coniferous, bog and deciduous forest habitats, oak in coniferous forests habitats, spruce in coniferous and bog forest habitats, birch and alder in bog and deciduous forest habitats. In reserve forests, birch (Fig. 6.5) and hornbeam were more likely to regenerate in coniferous forests habitats, spruce in moist habitats (bog coniferous and deciduous forest habitats, alder forests), ash and alder in alder and riparian forests, and rowan in all habitats. In the Strict Reserve, oak regenerated more frequently in bog habitats, hornbeam, maple and aspen in deciduous forest habitats, and lime, elm and fruit trees in alder forests. Birch and oak tall saplings were found more often in managed forests than in conservation forests. More spruce and alder saplings were also recorded in the coniferous and bog coniferous and deciduous forests. Reserve forests were characterized by a higher proportion of hornbeam in deciduous forest habitats. On the other hand, strict protection favoured birch regeneration in the coniferous forest habitats. It has been found that forest protection influenced the appearance of lime and oak tall saplings in the gaps (Chi^2 test $p < 0.05$) (Tab. 6.2).

6.4. Discussion

6.4.1. Natural gaps vs artificial gaps

In Białowieża Forest, mass dieback of spruce has been observed for years (Bobiec et al. 2011a; Brzeziecki et al. 2020). In managed forests, work is carried out to remove dead spruce trees infested by the bark beetle. Not only individual infected trees are removed, but also groups of trees. Therefore, anthropogenic gaps represent a large proportion in Białowieża Forest. Spruce dieback also causes natural gaps of varying sizes (Bobiec et al. 2011a). Regeneration was found to vary according to the origin of the gaps. Spruce, pine, and birch were more commonly found in gaps of anthropogenic origin, especially in coniferous and deciduous forest habitats. Gap management included oak and pine planting (Bobiec 2007). However, in our study we focused on natural regeneration in gaps. All plots with introduced pine trees were fenced. In Białowieża Forest, the high pressure of wildlife on regeneration makes it necessary to use fences (cf. Kuijper et al. 2010). Spruce most often regenerated naturally in gaps of anthropogenic origin as a result of sanitary cuts, which loosened the stand and initiated spruce regeneration.

Some tree species regenerated only in natural gaps. Brzeziecki et al. (2020) found that spruce and ash dieback in Białowieża Forest rarely promotes regeneration of species other than hornbeam or lime. These studies of regeneration in gaps confirmed the dominance of hornbeam in both gap types, especially in the small saplings stage (Bobiec 2007). In contrast, no abundant lime regeneration was found in the gaps in managed forests. Lime, ash, maple, and elm regenerated mainly in natural gaps.

The size of the gap did not affect the density of regeneration in the Białowieża Forest, except for the regeneration of birch and hornbeam. Detailed research results concerning the impact of the gap characteristics (size and geometry of gaps) on the number and presence of regeneration in gaps are presented in a separate publication.

6.4.2. Regeneration in gaps depending on the habitat or community

The most frequently regenerating species in the small seedlings and saplings layer was hornbeam, which primarily dominated in gaps that were located in deciduous forest habitats, as confirmed by H1. Numerous studies indicate that climate change and increased nitrogen deposition, may affect the species composition of forest stands in Białowieża Forest (Brzeziecki et al. 2016; Boczoń et al. 2018). Compared to the 19th century, the climate in Białowieża Forest is definitely warmer (especially in winter) and also drier (Boczoń et al. 2018). Hornbeam, as well as lime, are species associated with moderately humid climates that may recover better in warmer climates (Brzeziecki and Kienast 1994). In the gaps that were located in deciduous habitats, not only hornbeam regenerated, but also maple, lime, aspen, and elm. Bobiec (2007) also observed abundant regeneration of hornbeam and lime in gaps in Białowieża National Park. Some changes may be associated with natural disturbances (Seidl et al. 2017). The regeneration process is complex and usually asynchronous in nature (Bobiec 2007). Hornbeam is a species that regenerates continuously. In contrast, opportunistic species, such as small-leaved lime, oak, and pioneer species, are characterized by a wave-like mode of regeneration (Bobiec 2007). The increasing abundance of hornbeam may also be related to the presence of herbivores in Białowieża Forest. Hornbeam is one of the palatable species while tolerating game pressure (Churski et al. 2017; Bubnicki et al. 2019).

Spruce regenerated in the gaps much less frequently than hornbeam, especially in the seedlings layer, as confirmed by H2. Our findings are consistent with those of other authors (Bobiec 2007). This species was prevalent in gaps in the coniferous forest habitats (small saplings) and in bog coniferous and deciduous forests (small and tall saplings). Norway spruce was found throughout Białowieża Forest, in coniferous and very wet habitats. It is a taxon associated with boreal climate, which is cooler and wetter (Brzeziecki and Kienast 1994), and as a result, in Białowieża Forest, it is now receding from deciduous forest habitats and remains in the bog coniferous and deciduous forest habitats. The results of the regeneration density and occurrence in the gaps presented in this chapter are consistent with the study of Gazda and Miścicki (2016), who found more numerous spruce regeneration in dry alder forests or in mixed coniferous forests or bog deciduous forests. They also observed the receding of this species from previously occupied habitats – habitats that are now too dry.

Regeneration of light-demanding species such as pine, birch, and oak were noted mainly in gaps in the coniferous forest habitats, primarily in the seedlings and small saplings stages. The abundance of these species in the coniferous forest habitats was much lower than the abundance of hornbeam. Bobiec et al. (2011a) also reported numerous regeneration of oaks in mixed coniferous forest habitats compared to oaks located in deciduous forest habitats, at the same time clearly indicating the positive influence of gaps caused by spruce dieback on the regeneration of pedunculate oak. Shading by hornbeam is thought to contribute to the decline or disappearance of thermophilic species (Brzeziecki et al. 2018b), as well as other tree species (Brzeziecki et al. 2018a). The present study indicates that coniferous forest habitats influence in a positive way on the regeneration of pine. Pine seedlings were most common and advanced to the small saplings stage, but rarely to the tall saplings stage. Similar results were obtained by Paluch (2015), who indicated a decrease in the proportion of pine, oak and birch in the regeneration layer in Białowieża Forest. The sparse pine regeneration may be related to the fire regime in the area, which was quite frequent in the past. Pine, as a fire-tol-

erant species, was more likely to recover from disturbance (Niklasson et al. 2010; Zin et al. 2015). Some researchers even believe that natural regeneration is impossible in forest habitats without the help of a forester (Grzywiński 2006). Our study contradicts these statements. Although hornbeam has dominated the regeneration layer in Białowieża Forest for many years, other species, such as oak, spruce and birch, also regenerate. Despite hornbeam competition, the abundance of oak and spruce in the gaps is not decreasing (Bobiec 2007; Bobiec et al. 2011a, b). Birch and spruce were much more likely to regenerate in the gaps in the bog coniferous and deciduous forest habitats. It seems that not only spruce is retreating to moist habitats, but also birch. Bog habitats have not been overrun by hornbeam, which is significant competition for both tree species in deciduous forest habitats. In addition, the canopy of some species is important for regeneration. As Gazda and Miścicki (2016) found, the regeneration of birch and black alder in mixed coniferous forest habitats and in bog coniferous and deciduous forest habitats was quite strongly associated with pine canopy.

Habitats of typical alder, ash alder and riparian forest were favourable for alder and ash regeneration. Both species form stands in these habitats where they have found favourable conditions for regeneration in the gaps. Over the past 60 years, the forest stands in Białowieża Forest have undergone numerous changes resulting not only from the dying of spruce trees, but also from dying ash and elm trees (Gazda and Miścicki 2016). This phenomenon has an impact on natural regeneration of the mentioned species. Elm regeneration, which was most common in deciduous forest habitats, along with maple and aspen, declined. Also, ash regeneration was basically limited to alder and riparian habitats.

6.4.3. Type of protection versus natural regeneration in gaps

The origin of gaps affects the regeneration of trees in gaps, i.e., H3 was positively verified. In managed forests, regeneration of spruce, birch, and pine and oak dominated the gaps. Pedunculate oak is one of the most important species forming communities in Białowieża Forest (Więcko 1984; Brzezicki et al. 2016). In managed stands, it is planted in gaps in deciduous forest habitats as well as in coniferous forest habitats (shelterwood system). Spruce was also one of the key species in Białowieża Forest (Boczoń et al. 2018). In managed forest, it can also be introduced artificially when natural regeneration of this species is insufficient. Pine, on the other hand, was planted as part of conducting clear-cutting.

Gaps in the reserves area were dominated by hornbeam in the early stages of regeneration (seedlings and small saplings). The occurrence of hornbeam in nature reserves in Białowieża Forest was written, among others, by Brzezicki et al. (2016), who suggested two main trends of changes in the species composition of forest stands in this area. In the first one, they assumed a decrease in the share of light-demanding species, and in the second one – replacement of spruce by hornbeam and, to a lesser extent, lime in all forest communities. The results of study conducted by the authors confirm these changes. Hornbeam regenerated in large numbers not only under the canopy of stands, but also in gaps. In contrast, the abundance of spruce and birch in the gaps was twice smaller than that of hornbeam. Replacement of spruce by hornbeam is therefore likely. These results are consistent with numerous reports of hornbeam expansion in Białowieża Forest (e.g., Paluch 2015; Gabrysiak et al. 2021).

On the territory of the Strict Reserve, numerous regeneration of various tree species, including the light-demanding ones (oak and pine, but pine only in the seedlings phase), was found in the seedlings and small saplings phase. Among the shade-tolerant species, maple, lime, and elm were noted, but it was hornbeam that was most abundant. The numerous regeneration of hornbeam in the Strict Reserve can be associated with the predominance of oak-hornbeam communities in the area. In recent years, the proportion of light-demanding species has declined in the Strict Reserve, with a particularly drastic decline observed in pine (Brzezicki et al. 2016; Gazda and Miścicki 2016) under the canopy of stands. In contrast, the presence of shade-tolerant species such as lime and hornbeam were recorded much more frequently. Grzywiński (2006) pointed out the numerous occurrences of maple and ash in the seedlings layer, but observed that these species rarely formed the saplings layer, let alone the second storey, due to damage from animals. The results of our gap study support these observations. An interesting issue is the presence of oak in the tall sapling layer in the Strict Reserve. This result indicates that under favourable light conditions, despite game pressure, oak is able to regenerate in the gaps, contrary to the suggestion of Gazda and Miścicki (2016) that it is the presence of pine in the canopy of the stand that can be considered the most important factor for maintaining a significant proportion of oak and spruce. Similar results were obtained by Bobiec et al. (2011b), who found a beneficial effect of gaps on oak regeneration in Białowieża Forest.

6.5. Summary

The research presented here demonstrates the mechanisms that influence tree regeneration in gaps in Białowieża Forest. The presence of regeneration in gaps depends on habitat, conservation form, and origin. Gaps promote regeneration of both deciduous and coniferous species, although deciduous trees are more likely to regenerate. Hornbeam is the dominant species in regeneration in gaps, especially in deciduous forest habitats. Spruce also regenerates in gaps and is most often found in moist habitats. Reserve forests had a higher proportion of hornbeam than managed forests. In contrast, in conservation reserve, birch, lime, and oak regeneration was favoured in the gaps. Gap origin influenced the presence of regeneration. Spruce, pine and birch were found more often in artificial gaps. Comparing regeneration in gaps and under the stand canopy will provide an in-depth understanding of the role of gaps in regeneration in Białowieża Forest.

References

- Bobiec A. 2007. The influence of gaps on tree regeneration: a case study of the mixed lime-hornbeam (*Tilio-Carpinetum* Tracz. 1962) communities in the Białowieża Primeval Forest. *Polish Journal of Ecology*, 55: 441–455.
- Bobiec A., Jaszcz E., Wojtunik K. 2011a. Oak (*Quercus robur* L.) regeneration as a response to natural dynamics of stands in European hemiboreal zone. *European Journal of Forest Research*, 130: 785–797.
- Bobiec A., Kuijper D.P., Niklasson M., Romankiewicz A., Solecka K. 2011b. Oak (*Quercus robur* L.) regeneration in early successional woodlands grazed by wild ungulates in the absence of livestock. *Forest Ecology and Management*, 262: 780–790.

- Boczoń A., Kowalska A., Ksepko M., Sokołowski K. 2018. Climate Warming and Drought in the Białowieża Forest from 1950–2015 and Their Impact on the Dieback of Norway Spruce Stands. *Water*, 10: 1502.
- Brzeziecki B., Andrzejczyk T., Żybura H. 2018a. Odnowienie naturalne drzew w Puszczy Białowieskiej. *Sylwan*, 162: 883–896.
- Brzeziecki B., Ciużycki W., Keczyński A. 2018b. Zmiany flory roślin naczyniowych runa leśnego w latach 1959–2016 na stałej powierzchni badawczej w oddziale 319 Białowieskiego Parku Narodowego. *Sylwan*, 162(12): 980–988.
- Brzeziecki B., Kienast F. 1994. Classifying the life-history strategies of trees on the basis of the Grimian model. *Forest Ecology and Management*, 69: 167–187.
- Brzeziecki B., Pommerening A., Miścicki S., Drozdowski S., Żybura H. 2016. A common lack of demographic equilibrium among tree species in Białowieża National Park (NE Poland): evidence from long-term plots. *Journal of Vegetation Science*, 27: 460–469.
- Brzeziecki B., Woods K., Bolibok L., Zajączkowski J., Drozdowski S., Bielak K., Żybura H. 2020. Over 80 years without major disturbance, late-successional Białowieża woodlands exhibit complex dynamism, with coherent compositional shifts towards true old-growth conditions. *Journal of Ecology*, 108: 1138–1154.
- Bubnicki J.W., Churski M., Schmidt K. 2019. Linking spatial patterns of terrestrial herbivore community structure to trophic interactions. *eLife*. DOI: 10.7554/eLife.44937.
- Churski M., Bubnicki J. W., Jędrzejewska B., Kuijper D.P.J., Cromsigt J. 2017. Brown world forests: increased ungulate browsing keeps temperate trees in recruitment bottlenecks in resource hotspots. *New Phytologist*, 214:158–168. DOI: 10.1111/nph.14345.
- Gabrysiak K.A., Paluch R., Gawryś R. 2021. 30-Year Changes in Oak-Hornbeam Forest after Windthrow. *Forests* 12: 600.
- Gazda A., Miścicki S. 2016. Prognoza zmian składu gatunkowego drzewostanów Białowieskiego Parku Narodowego. *Sylwan*, 160: 309–319.
- Grodzki W. 2016. Gradacyjne występowanie kornika drukarza *Ips typographus* (L.) (Col.: Curculionidae, Scolytinae) w aspekcie kontrowersji wokół Puszczy Białowieskiej. *Leśne Prace Badawcze*, 77(4): 324–331.
- Grzywiński R. 2006. O odnowieniu naturalnym Puszczy. *Las Polski*, 20–21.
- Kern C.C., Burton J. I., Raymond P., D'Amato A., Keeton W., Royo A., Walters M., Webster C., Willis J. 2017. Challenges facing gap-based silviculture and possible solutions for mesic northern forests in North America. *Forestry: An International Journal of Forest Research*, 90: 4–17.
- Kern C.C., D'Amato A. W., Strong T. F. 2013. Diversifying the composition and structure of managed, late-successional forests with harvest gaps: what is the optimal gap size? *Forest Ecology and Management*, 304: 110–120.
- Kuijper D.P., Jędrzejewska B., Brzeziecki B., Churski M., Jędrzejewski W., Żybura H. 2010. Fluctuating ungulate density shapes tree recruitment in natural stands of the Białowieża Primeval Forest, Poland. *Journal of Vegetation Science*, 21: 1082–1098.
- Martins, S.V., Rodrigues, R.R. 2002. Gap-phase regeneration in a semideciduous mesophytic forest, south-eastern Brazil. *Plant Ecology*, 163: 51–62.
- Millar C.I., Stephenson N.L. 2015. Temperate forest health in an era of emerging megadisturbance. *Science*, 349: 823–826.
- Montgomery R. A., Reich P. B., Palik B. J. 2010. Untangling positive and negative biotic interactions: views from above and below ground in a forest ecosystem. *Ecology*, 91: 3641–3655.
- Niklasson M., Zin E., Zielonka T., Feijen M., Korczyk A., Churski M., Samojlik T., Jędrzejewska B., Gutowski J. M., Brzeziecki, B. 2010. A 350-year tree-ring fire record from Białowieża Primeval Forest, Poland: Implications for Central European lowland fire history. *Journal of Ecology*, 98: 1319–1329.
- Paluch R. 2015. Wieloletnie zmiany składu gatunkowego drzewostanów naturalnych w Puszczy Białowieskiej. *Sylwan*, 159 (4): 278–288.
- Pierzgalski E., Tyszka J., Stolarek A. 2012. Powodzie i susze w lasach. IMGW, Seria: Monografie IMGW-PIB. Warszawa 3: 243–255.
- Raffa K.F., Aukema B.H., Bentz B.J., Carroll A., Hicke J., Turner M., Romme W. 2008. Cross-scale drivers of natural disturbances prone to anthropogenic amplification: the dynamics of bark beetle eruptions. *Bioscience*, 58: 501–517.
- Runkle J.R. 1992. Guidelines and sample protocol for sampling forest gaps. US Department of Agriculture, Forest Service, Pacific Northwest Research Station.
- Sapkota I.P., Tigabu M., Odén P. C. 2009. Species diversity and regeneration of old-growth seasonally dry Shorea robusta forests following gap formation. *Journal of Forestry Research*, 20: 7–14.
- Seidl R., Thom D., Kautz M., Martin-Benito D., Peltoniemi M., Vacchiano G., Wild J., Ascoli D., Petr M., Honkaniemi J., Lexer M.J., Trotsiuk V., Mairota P., Svoboda M., Fabrika M., Nagel T.A., Reyer C.P.O. 2017. Forest disturbances under climate change. *Nature Climate Change*, 7: 395–402.
- Spies T.A., Franklin J.F., Klopsch M. 1990. Canopy gaps in Douglas-fir forests of the Cascade Mountains. *Canadian Journal of Forest Research*, 20: 649–658.
- Stephens S.L., Burrows N., Buyantuyev A., Gray R.W., Keane R.E., Kubian R., Liu S., Seijo F., Shu L., Tolhurst K.G., van Wagtenonk J. W. 2014. Temperate and boreal forest mega-fires: characteristics and challenges. *Frontiers in Ecology and the Environment*, 12: 115–122.
- Stereńczak K., Kraszewski B., Mielcarek M., Piasecka Ż. 2017. Inventory of standing dead trees in the surroundings of communication routes—The contribution of remote sensing to potential risk assessments. *Forest Ecology and Management*, 402: 76–91.
- Turner M.G. 2010. Disturbance and landscape dynamics in a changing world. *Ecology*, 91: 2833–2849.
- Wesołowski T., Kujawa A., Bobiec A., Bohdan A., Buchholz L., Chylarecki P., Engel J., Falkowski M., Gutowski J.M., Jaroszewicz B., Nowak S., Orczewska A., Mysłajek R., Walankiewicz W. 2016. Spór o przyszłość Puszczy Białowieskiej: mity i fakty. Głos w dyskusji. *The Conflict on the Future of Białowieża Forest: Myths and Facts. Chrońmy Przyrodę Ojczystą*, 72: 83–99.
- Więcko E. 1984. Białowieża Primeval Forest. PWN-Polish Scientific Publishers, Warszawa, 1–309.
- Zhu J., Lu D. & Zhang W. 2014. Effects of gaps on regeneration of woody plants: a meta-analysis. *Journal of Forestry Research*, 25: 501–510.
- Zin E., Drobyshch I., Bernacki D., Niklasson M. 2015. Dendrochronological reconstruction reveals a mixed-intensity fire regime in *Pinus sylvestris*-dominated stands of Białowieża Forest, Belarus and Poland. *Journal of Vegetation Science*, 26: 934–945.

7. Dendrochronological reconstruction of stand dynamics in Białowieża Forest

Ewa Zin¹, Kamil Pilch¹, Marcin Klisz², Agnieszka Bosak¹, Paula Calusińska¹

¹ Forest Research Institute, Department of Natural Forests, 6 Park Dyrekcyjny St., 17-230 Białowieża

² Forest Research Institute, Department of Silviculture and Genetics, Sękocin Stary, 3 Braci Leśnej St.,

05-090 Raszyn

{e.zin, k.pilch, m.klisz, a.bosak, p.calusinska}@ibles.waw.pl

Abstract

Despite the long tradition of research on forest dynamics in Białowieża Forest, the number of studies reconstructing the history of individual tree stands or forest communities based on tree ring analyses is still limited. The main goal of the dendrochronological research conducted within the ForBioSensing project was to add more empirical data of this type to the knowledge of the long-term dynamics of Białowieża Forest, which, among other things, is also a valuable contribution to the development of dendroclimatic research in the area. The research material collected from 100 study plots in tree stands older than one hundred years in the Polish part of Białowieża Forest made it possible to characterise the age structures of tree stands in each plot and to identify the regeneration patterns of certain tree taxa over the years, as well as to establish master chronologies of the main tree species in the area, which can be used for dendroclimatic analyses. As an example of such an analysis, this chapter presents the response of Norway spruce (*Picea abies* (L.) Karst.) to changing climatic conditions in a selected study plot. Numerous populations of trees up to 350–400 years old were recorded, dating from the first half of the 17th century. Both mechanisms of tree regeneration were observed: cohort regeneration and continuous regeneration. The main climatic factors affecting radial growth of spruce were: winter temperature and precipitation, spring temperature, summer precipitation (positive influence) and February precipitation, November precipitation of the previous year, June temperature (negative influence). The negative impact of drought periods was obvious. Although the conducted research has significantly increased the knowledge about the history and development of tree stands in Białowieża Forest, including their response to changing climatic conditions, the need for further dendrochronological studies in this area is still considerable.

Keywords: tree regeneration, radial increment, age structure, climatic conditions

7.1. Introduction

Trees are one of the natural archives of forest history (e.g., Niklasson and Granström 2000; Kullman 2002; Heyerdahl et al. 2014; Babst et al. 2017), and dendrochronology, i.e., dating of tree rings, is a tool that allows precise determination of tree age and long-term stand dynamics with annual or even seasonal resolution (Stokes and Smiley 1968; Zielski

and Krąpiec 2004). Currently, this tool is widely used in studies of forest ecosystems around the world, including analyses of tree age structure (e.g., Wallenius et al. 2002; Brown and Wu 2005), history of various types of biotic disturbances such as insect outbreaks, mass emergence of pathogenic fungi, etc. (e.g., Fraver et al. 2007; Demidko et al. 2021), and abiotic disturbances such as windthrow, snow damage, floods, or fires (e.g., Zielonka et al. 2010; Heyerdahl et al. 2014), dendroclimatic studies that include reconstruction of individual climate parameters in the past, modelling of the adaptation of individual tree species and/or forest communities to changing climate conditions, etc. (e.g., Anchukaitis et al. 2013; Babst et al. 2013), geomorphological (e.g., Malik et al. 2021), dendroarchaeological, palaeoecological (e.g., Kullman 2002; Li et al. 2015), and many other analyses.

Białowieża Forest is one of the best-preserved forest areas of the Central European Lowland, where tree stands with a high degree of naturalness still exist (Jaroszewicz et al. 2019; see Chapt. 2). Therefore, it is treated as a model ecosystem in forest ecology (Gutowski and Jaroszewicz 2004) and as a reference area for other temperate European forests (Faliński 1986; Ellenberg 1996; Peterken 1996; Leuschner and Ellenberg 2017). In this area there is unique material for dendrochronological research that is almost non-existent elsewhere in Central Europe. These are ancient, multi-aged tree populations and their remains in the form of coarse woody debris (stumps, snags, logs), whose tree rings allow us to reconstruct the development history of individual trees and stands, including past disturbances.

Ecological research in Białowieża Forest has a very long tradition (see Chapt. 2). However, the amount of empirical dendrochronological data is still very limited (E. Zin and K. Pilch, unpublished data) and therefore relatively little is known about the maximum age of individual tree species, long-term stand dynamics, natural regeneration mechanisms of individual tree taxa, and disturbance history and dynamics in this area (see e.g., Ząbek and Zaręba 1958; Korczyk 1994; Niklasson et al. 2010; Bobiec et al. 2011b; Bobiec 2012; Zin et al. 2015; Yermokhin et al. 2017; Spînu et al. 2020). An increase in the proportion of spruce at the turn of the 19th and 20th centuries is discussed and interpreted as an effect of overabundance and the resulting greatly increased herbivory pressure from ungulates at that time (Faliński 1986; Jędrzejewska et al. 1997). Long-term analyses of stand dynamics in the Białowieża National Park documented significant changes in tree species composition during the last decades, in particular a decrease in the proportion of species such as oak, pine, or spruce in favour of hornbeam and lime (e.g., Bernadzki et al. 1998; Kuijper et al. 2010b; Brzeziecki et al. 2016, 2020). Analogous observations (lack of pine regeneration, spread of shade-tolerant species) were also made at other sites in Białowieża Forest (Sokołowski 1991, 1999; Niklasson et al. 2010; Drozdowski et al. 2012; Paluch 2015; Zin et al. 2015; Zin 2016; Spînu et al. 2020; Brzeziecki et al. 2021; Gabrysiak et al. 2021). Possible causes of these changes include the activity of herbivorous ungulates, human land management (including past cattle grazing), habitat eutrophication, and climate change (Faliński 1986; Sokołowski 1991, 1999; Bernadzki et al. 1998, 2001; Brzeziecki et al. 2016, 2020). On the other hand, tree ring studies show that the reason for the lack of regeneration and the gradual decrease in the proportion of light-demanding tree species in favour of late-successional species is the loss of fires that once occurred in Białowieża Forest (Niklasson et al. 2010; Zin et al. 2015; Spînu et al. 2020).

Since problems with natural regeneration of some tree species and changes in stand structure are also observed in other regions of Poland (Matuszkiewicz 2007) and Europe (see e.g., Vera 2000), explaining their causes through a better understanding of the mechanisms determining regeneration and stand dynamics in Białowieża Forest is important for sustainable management and conservation of natural resources not only at the local, but also at the national or European level.

Since there are not many studies that reconstruct the history of individual tree stands or forest communities based on tree ring analyses (Niklasson et al. 2010; Bobiec 2012; Zin et al. 2015; Yermokhin et al. 2017; Spínu et al. 2020), the main objective of the dendrochronological research conducted within the ForBioSensing project was to complement the existing knowledge on the long-term stand dynamics of Białowieża Forest with more empirical data of this type. The dendrochronological reconstruction of the history and long-term dynamics of selected forest stands was aimed at the precise determination of their age, origin, and periodic or sudden changes they experienced (including possible disturbances), which in turn would allow for a better understanding of the mechanisms determining the regeneration dynamics of individual tree species (continuous regeneration vs. cohort regeneration). In turn, the established tree ring master chronologies of the main tree species of Białowieża Forest, should, among other things, make a valuable contribution to the development of dendroclimatic research in the area, which is still limited to a small number of studies (Jaroszewicz 1993; Koprowski and Zielski 2008; Yermokhin et al. 2010, 2016, 2017; Yermokhin and Savel'ev 2011). In this chapter, we present the response of Norway spruce (*Picea abies* (L.) Karst.) to changing climatic conditions as an example of dendroclimatic analyses.

7.2. Materials and Methods

7.2.1. Fieldwork

In the vicinity of selected permanent study plots used for stand monitoring (i.e., monitoring plots, see Chapt. 1 and Map 1), 100 separate permanent study plots were established to analyse the age structure, history, and long-term dynamics of selected tree stands, as well as to build the tree ring master chronologies of the main tree species in Białowieża Forest (so-called dendrochronological plots). These plots were located in forest stands that were over 100 years old (based on the data of the Forest Management Plan for the period 2011–2021) and were characterised by a semi-natural structure, indicated by the presence of uneven-aged tree populations and a large amount of coarse woody debris (features assessed in the field), and situated in the Polish part of Białowieża Forest outside the Białowieża National Park, both in nature reserves (43 plots) and in managed forests under the responsibility of the Białowieża, Browsk, and Hajnówka Forest Districts (57 plots) (Fig. 7.1). They were circular plots with a radius of 12.52 m (area 500 m²). The centre of each dendrochronological plot was stabilised with a metal pipe embedded at ground level and an oak stake protruding above the ground, and its coordinates were recorded using a land surveying method. In each plot, the following characteristics of all standing, living, and dead trees with a diameter at breast height (i.e., 1.3 m above the ground, DBH) of 5 cm or greater were determined: tree species,

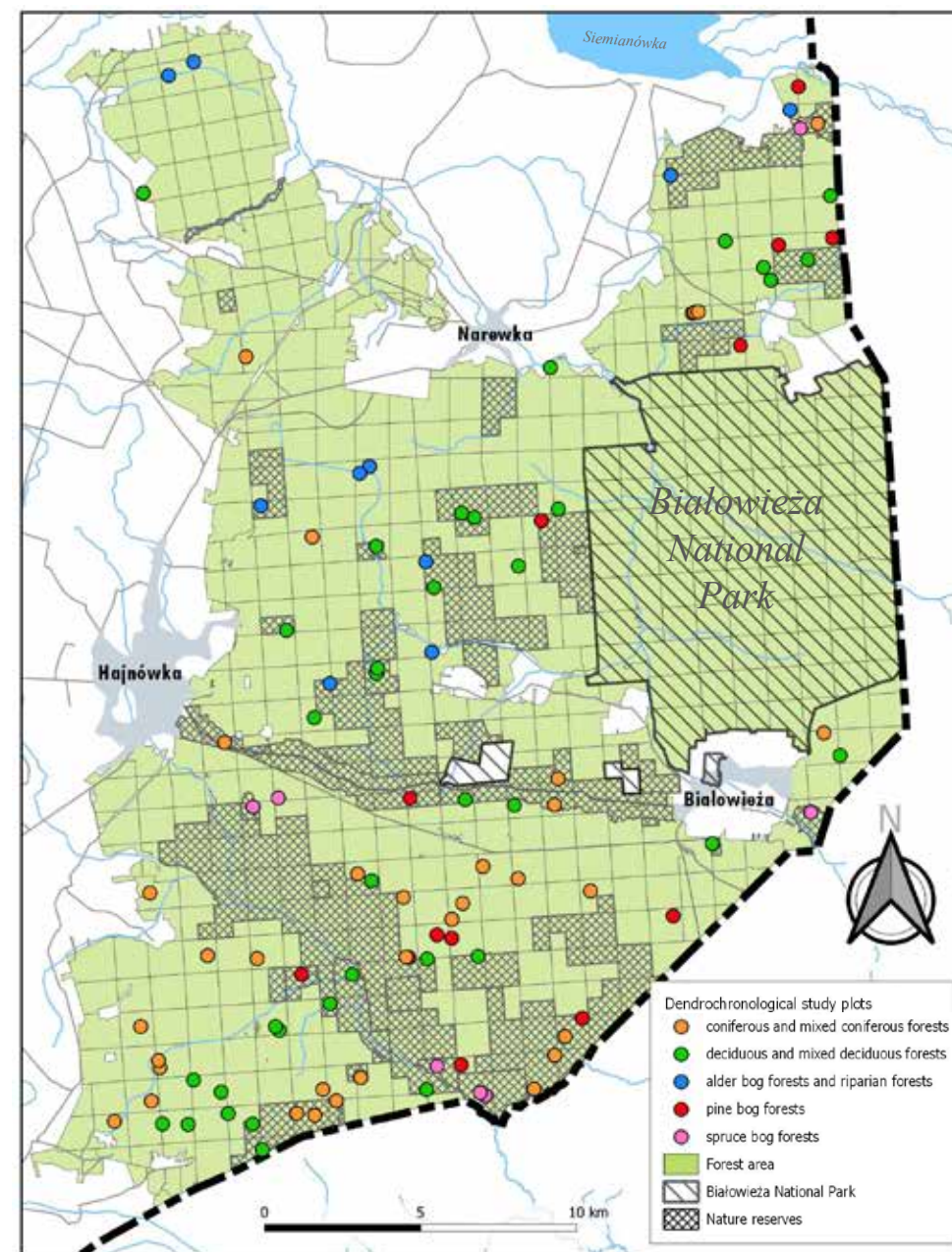

Figure 7.1. Location of the dendrochronological study plots of the ForBioSensing project (divided into five habitat classes) in the Polish part of Białowieża Forest

DBH, height, crown base height, damage, condition (living/dead), location: azimuth, distance from plot centre. Then increment cores were collected from the above trees using an increment borer. Because sampling height can significantly affect tree age determination, especially for shade-tolerant species or suppressed individuals (Niklasson 2002; see Niklasson et al. 2010; Spînu et al. 2020), increment cores were taken as close to the ground as possible to determine the true age of trees (Fig. 7.2). If a complete increment core could not be taken from a particular tree due to decay, it was determined which part of the stem was missing, and then an additional core was taken from the nearest individual of the species in question with a similar DBH outside the study plot, as close to the plot as possible. Additionally, whenever possible, to establish master chronologies (Stokes and Smiley 1968; Schweingruber et al. 1990; Yamaguchi 1991; Zielski and Krąpiec 2004), potentially oldest tree specimens of individual species were selected outside the plot and sampled according to the methodology described previously. In addition, whenever possible, supplementary dendrochronological material in the form of partial or full cross sections from stumps or logs was collected within or near the plot for the same purpose.



Figure 7.2. Collecting a tree ring sample (increment core) using an increment borer (photo K. Pilch)

7.2.2. Tree Ring Analysis

The collected dendrochronological material was successively glued to stabilising sticks or boards, described, dried, and then sanded with progressively finer grades of sandpaper (grain size 40–600) to make the tree ring sequences appear clear. In some cases, a scalpel cut and zinc paste were also applied to increase the visibility of the wood cells. Wood samples were then appropriately labelled, scanned, and dated. Tree ring dating (so-called

cross-dating) and ring counting were performed under a dissecting microscope with 6–40× magnification according to standard dendrochronological methodology (Stokes and Smiley 1968; Yamaguchi 1991; Schweingruber et al. 1990; Zielski and Krąpiec 2004). For trees where the increment core slightly missed the pith, the pith year was estimated based on the distance from the pith and the average annual increment at the youngest age, using a special tool called *pith locator* (Applequist 1958). Determination of germination years allowed estimation of tree age at coring height (see Heyerdahl et al. 2014).

After discarding samples with excessive decay or damage that prevented cross-dating and accurate age determination, a total of 4420 trees were used for the final dendrochronological analyses. The tree ring data collected allowed us to describe the age structure of the tree stands in each study plot, which enabled the characteristics of the regeneration patterns of individual tree species over time. The dendrochronological material was analysed in five predetermined habitat classes (Tab. 7.1).

Table 7.1. Division of the dendrochronological study plots into habitat classes. FDF – fresh deciduous forest, FMDF – fresh mixed deciduous forest, HDF – humid deciduous forest, HMDF – humid mixed deciduous forest, FCF – fresh coniferous forest, FMCF – fresh mixed coniferous forest, HCF – humid coniferous forest, HMCF – humid mixed coniferous forest, ABF – alder bog forest, AASF – alder-ash streamside forest, BMCF – bog mixed coniferous forest, BMDF – bog mixed deciduous forest, BCF – bog coniferous forest

No.	Habitat class	Forest habitat type	Number of study plots per class
1.	deciduous and mixed deciduous forests	FDF, FMDF, HDF, HMDF	36
2.	coniferous and mixed coniferous forests	FCF, FMCF, HCF, HMCF	33
3.	alder bog forests and riparian forests	ABF, AASF	10
4.	spruce bog forests	BMCF, BMDF	7
5.	pine bog forests	BCF	14
Total			100

In order to analyse the response of trees in Białowieża Forest to changing climatic conditions, using Norway spruce as an example, a study plot from the class of coniferous and mixed coniferous forests was randomly selected from the plots where the presence of at least 15 spruce trees was recorded. The tree ring material collected from these plots did not exhibit decay or damage, which allowed dating of complete tree ring sequences and precise determination of tree age. Site chronologies of this tree species were then established by measuring the width of the annual rings to an accuracy of 0.01 mm (in the study material digitised with the scanner) using dedicated dendrochronology software (WinDendro, Regent Instruments Inc; CooRecorder, Cybis Elektronik & Data AB). Site chronologies were indexed to remove long-term growth trends related to age, competition effects, or changes in canopy closure due to various disturbances in the main stand layer, and to highlight short-term trends related to the influence of climatic conditions. For this purpose, a *cubic smoothing spline* method

with an interval of 30 years was used (“dplr” package in R software, Cook and Peters 1981; Speer 2010). Daily climate data for the period 1920–2020 from the E-OBS grid climate database with a spatial resolution of $0.1^\circ \times 0.1^\circ$ (version 23.0e) were used for analyses of the effects of climatic conditions on spruce growth patterns (Cornes et al. 2018). Mean daily air temperature and daily precipitation sum were used as climate variables. Climate sensitivity analyses considered the period from September of the previous year to September of the current year. The analyses of correlations of the indexed tree ring widths with the main climate variables were performed using a *nonlinear Bayesian regularisation training algorithm* method for a time window from seven to 30 days (“dendroTool” package in R software, Jevšenak and Levanič 2018). Monthly mean air temperatures, monthly precipitation sums, and standardised precipitation evapotranspiration indices integrated over three (SPEI3) and six months (SPEI6), which determine the normalised difference between precipitation and potential evapotranspiration in the respective period (“SPEI” package in R software, Beguería et al. 2014), were used to calculate the non-stationary (i.e., moving) correlations between tree ring width and monthly climatic variables. Correlation coefficients were calculated for a 25-year window moving with a 1-year offset for the climatic variables from September of the previous year to August of the current year (“treeclim” package in R software, Zang and Biondi 2015). The effect of extreme drought conditions on the occurrence of narrow tree rings (so-called negative pointer years) was quantified for negative pointer years determined with a 5-year moving time window and a growth response threshold for 60% of the tree ring series (“pointRes” package in R software, Cropper 1979; van der Maaten-Theunissen et al. 2015). Years in which drought index values fell below -2 were classified as years of extreme drought (McKee et al. 1993; Vicente-Serrano et al. 2010; Paulo et al. 2012). For these years, the growth response in the three years before and three years after the extreme drought year was determined using *Superposed Epoch Analysis* (SEA) with 1000-fold sampling (“dplr” package in R software, Chree 1914).

7.3. Results and Discussion

7.3.1. History and Long-Term Dynamics of Selected Tree Stands in Białowieża Forest

The reconstructed age structures of one hundred selected old-growth stands in the Polish part of Białowieża Forest revealed numerous populations of trees 350–400 years old, i.e., from the first half of the 17th century. Interestingly, such old generations occurred in almost all habitat classes. The only exceptions, but not very different from the rest, were alder bog forests and riparian forests, where the oldest generations represented the 320–340 year age class, i.e., trees from the second half of the 17th century (Fig. 7.3–7.9). Two mechanisms of tree regeneration were observed in all habitat classes: cohort regeneration and continuous regeneration (Fig. 7.4 and 7.6).

The highest number of tree species (16) was observed in the habitat class of deciduous and mixed deciduous forests. All tree species typical for Białowieża Forest were observed on the study plots (Faliński 1986; Jędrzejewska and Jędrzejewski 1998), namely pedunculate oak (*Quercus robur* L.), small-leaved lime (*Tilia cordata* Mill.), Norway maple (*Acer pla-*

tanoides L.), Norway spruce (*Picea abies* (L.) Karst.), common ash (*Fraxinus excelsior* L.), common hornbeam (*Carpinus betulus* L.), black alder (*Alnus glutinosa* (L.) Gaertn.), silver birch (*Betula pendula* Roth.), Scots pine (*Pinus sylvestris* L.), aspen (*Populus tremula* L.), wych elm (*Ulmus glabra* Huds.), European white elm (*Ulmus laevis* Pall.). In single study plots, the occurrence of much rarer taxa was noted, such as sessile oak (*Quercus petraea* (Matt.) Liebl.), common pear (*Pyrus communis* L. s.l.), or apple (*Malus* spp.), or even taxa that do not occur naturally in the area, such as common beech (*Fagus sylvatica* L.) (Faliński 1986) (Fig. 7.3). Hornbeam was the most numerous species and occurred in all 36 study plots. On the vast majority of study plots, the oldest tree generations were represented by oak, on some plots also by pine, and on some also by ash, maple, or spruce. The oldest populations in this habitat class were found in oak and pine. However, it is worth noting that spruce, ash, maple, and hornbeam trees older than 240 years were also found (Fig. 7.3). Of all 36 study plots in this habitat class, only two had an age structure where the oldest generations represented tree ages less than 200 years. Regeneration cohorts of late-successional, shade-tolerant species (hornbeam, spruce, lime, maple) from the first half of the 20th century were found in nearly all study plots (Fig. 7.4). The reasons for this phenomenon could be various, including: increasing canopy closure and thus shading of forest stands (which could result from the disappearance of earlier disturbances leading to a decrease in stand density and increased light availability in forest fragments), changes in meteorological and hydrological conditions, ungulate pressure (Kuijper et al. 2010a,b; Spīnu et al. 2020). Interestingly, as mentioned above, the presence of late-successional species belonging to older generations (i.e., trees more than one hundred or even two hundred years old) was detected in some study plots. However, in no case was this a regeneration cohort of a particular tree species, but rather single individuals. The long-lived, light-demanding species, namely oak and pine, generally represented much older generations. Pine, whose potential for successful regeneration in multi-species rich deciduous and mixed forests is very limited due to its high light demand (Faliński 1986; Brzeziecki and Kienast 1994; Ellenberg 1996; Kuijper et al. 2010b; Brzeziecki et al. 2016, 2020), was recorded in a relatively large number of study plots in this habitat class (n=23, 63.89%). Specimens currently belonging to age classes ranging from 120–140 to 260–280 years, with the vast majority falling within the centennial regeneration period represented by age classes ranging from 160–180 to 240–260 years, confirm that pine successfully regenerated on these study plots from the second half of the 18th century to the second half of the 19th century. Individual younger specimens, dating from the 1930s and 1940s, i.e., approximately 80–90 years old today, and much older specimens, approximately and over 350 years old, were also recorded. Oak regenerated over a similar period, but ranged further back (age classes up to 400 years) – from the first half of the 17th century to the second half of the 19th century. Again, there were occasional representatives of younger age classes that extended back to the 1950s and were thus about 70 years old (Fig. 7.3). Interestingly, such sparse occurrence of the youngest oak generations seems to confirm reports of a decline in effective regeneration of this species (e.g., Paluch 2005) and a significant decrease in its proportion (Bernadzki et al. 1998; Kuijper et al. 2010b; Drozdowski et al. 2012; Brzeziecki et al. 2016, 2020) in Białowieża Forest. However, it should be mentioned that there are also works confirming the fact of regular and effective occurrence of young oak generations in this area (Sokołowski 1991; Bobiec et al. 2011a,b; Bobiec and Bobiec 2012). Factors affecting this phenomenon in Białowieża Forest include the presence of dead wood that serves as protection against browsing (Bobiec et al. 2011a; Smit et al. 2012), and the

proximity of other, more preferred components of herbivore diet which play an analogous role in oak regeneration (Bobiec et al. 2011b), the decline of spruce stands as a disturbance that increases the amount of light in the stand and thus promotes light-demanding oak (Bobiec et al. 2011a; Bobiec and Bobiec 2012), and the movement and consumption of acorns by wild boars and rodents (van Ginkel et al. 2013). These results are in marked contrast to Vera's (2000) hypothesis that light-demanding species (including oak) do not regenerate naturally in closed-canopy forests dominated by shade-tolerant tree species because they require open areas created by the activity of large herbivores (the so-called savanna landscape type) to establish effectively. In this context, it is particularly interesting that on some of the study plots, in addition to the already mentioned regeneration cohorts of shade-tolerant species in the 20th century, regeneration cohorts were also observed in the more distant past, from the 18th to the first half of the 19th century. In almost all cases, these were regeneration cohorts of light-demanding species (oak, pine) (Fig. 7.4), which may indicate previous disturbances that increased light availability in the forest stands (Aldrich et al. 2010; Bobiec and Bobiec 2012; Flatley et al. 2015; Spînu et al. 2020). The amount of empirical tree ring data documenting analogous regeneration processes of species with different light requirements in temperate rich deciduous and mixed deciduous forests in Europe is practically limited to a single study from Białowieża Forest, which showed the relationship between demographic changes in tree populations and the disappearance of fires (Spînu et al. 2020). The recorded age structures in many study plots in the habitat class of deciduous and mixed deciduous forests suggest that these disturbances were not limited to individual stands, but were a widespread phenomenon in the area. Interestingly, the shift from light-demanding, early-successional tree species to shade-tolerant, late-successional taxa in the absence of fire has long been known from eastern North America. This has been described using the term *mesophication* (Nowacki and Abrams 2008) and confirmed by a number of studies, including tree ring research (e.g., Aldrich et al. 2010; Flatley et al. 2015), recently summarised by Lafon et al. (2017).

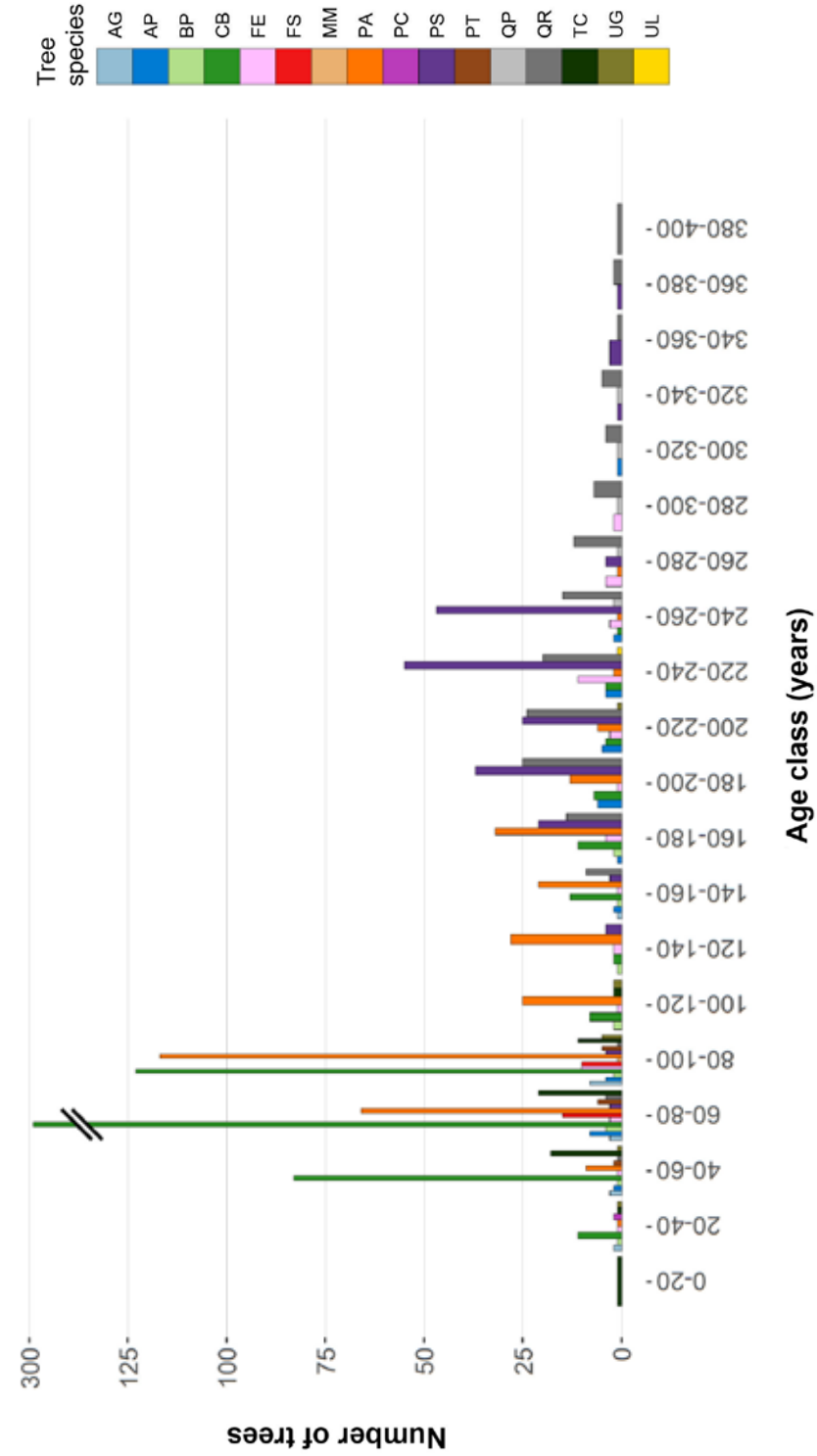

Figure 7.3. Age structure of the tree stands on dendrochronological study plots of the ForBioSensing project representing the habitat class of deciduous and mixed deciduous forests in the Polish part of Białowieża Forest (n=36). AG – *Alnus glutinosa*, black alder, AP – *Acer platanoides*, Norway maple, BP – *Betula pendula*, silver birch, CB – *Carpinus betulus*, common hornbeam, FE – *Fraxinus excelsior*, common ash, FS – *Fagus sylvatica*, common beech, MM – *Malus spp.*, apple, PA – *Picea abies*, Norway spruce, PC – *Pyrus communis*, common pear, PS – *Pinus sylvestris*, Scots pine, PT – *Populus tremula*, aspen, QP – *Quercus petraea*, sessile oak, QR – *Quercus robur*, pedunculate oak, TC – *Tilia cordata*, small-leaved lime, UG – *Ulmus glabra*, wych elm, UL – *Ulmus laevis*, European white elm

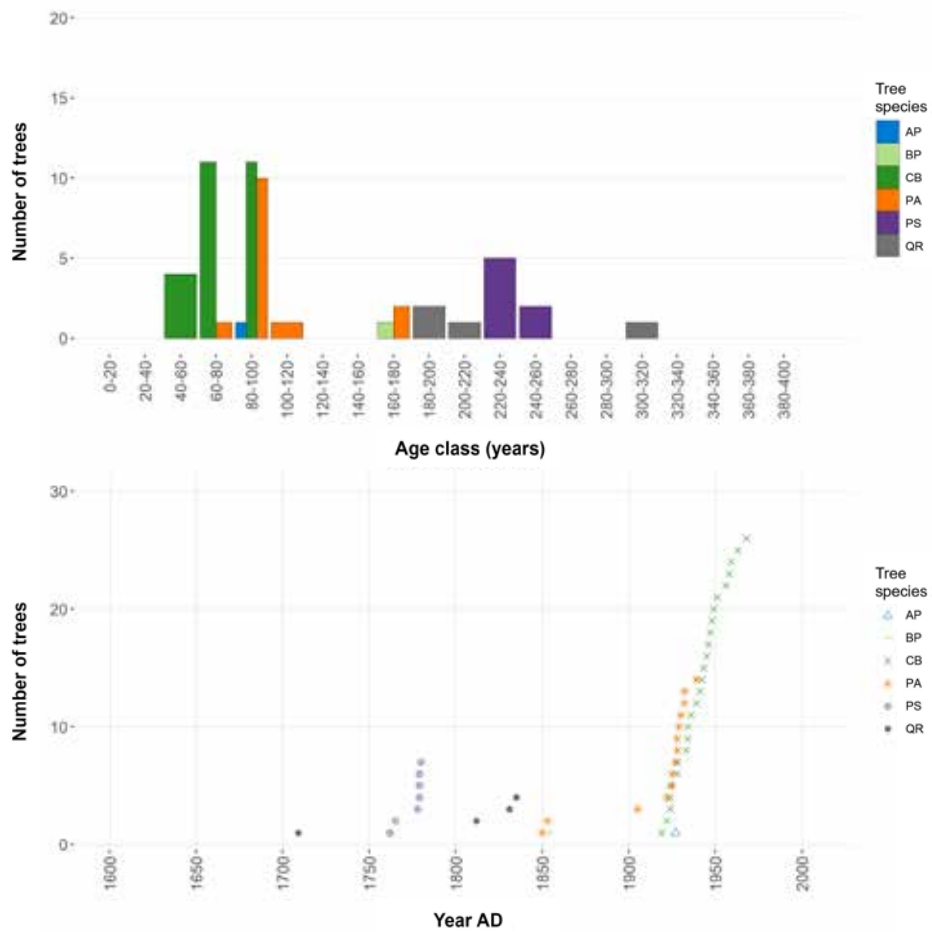

Figure 7.4. Age structure of a tree stand on a sample dendrochronological study plot of the ForBioSensing project representing the habitat class of deciduous and mixed deciduous forests in the Polish part of Białowieża Forest. AP – *Acer platanoides*, Norway maple, BP – *Betula pendula*, silver birch, CB – *Carpinus betulus*, common hornbeam, PA – *Picea abies*, Norway spruce, PS – *Pinus sylvestris*, Scots pine, QR – *Quercus robur*, pedunculate oak. Upper diagram – age class distribution, lower diagram – cumulative germination years

Eight tree species were recorded in the habitat class of coniferous and mixed coniferous forests. Scots pine and Norway spruce were the most abundant species and were found in every study plot, often unaccompanied by other taxa. Silver birch, pedunculate oak, aspen, common hornbeam, Norway maple, and black alder were rare or occurred as single specimens. The separation of age classes between the two main tree species, i.e., pine and spruce, was clearly visible in the studied tree stands. Scots pine formed older populations, which today represent age classes ranging from 120–140 to 360–380 years, confirming the successful regeneration of this species from the first half of the 17th century to the second half of

the 19th century. The vast majority of specimens were trees in the age classes ranging from 140–160 to 260–280 years. Spruce populations belonged to age classes ranging from 20–40 to 220–240 years, with the majority of trees representing age classes ranging from 20–40 to 180–200 years. This confirms the effective regeneration of this tree species since the second half of the 18th century. However, it must be mentioned that it was a very strong phenomenon from the mid-19th century to the mid-20th century (Fig. 7.5). Pine populations showed the presence of regeneration cohorts from the 18th and/or 19th centuries (mostly from the first half of the century). In contrast, spruce cohorts on most study plots were from the second half of the 19th century and/or the first half of the 20th century. In addition to regeneration cohorts, the occurrence of continuous regeneration of both species was also noted, mostly in the period before or between the regeneration cohorts mentioned above (see Fig. 7.6). The presence of fire scars in tree ring material from some study plots, and dendrochronological data from other sites in Białowieża Forest (Niklasson et al. 2010; Zin et al. 2015; Zin 2016), as well as a number of studies from the boreal region of Europe (Niklasson and Drakenberg 2001; Wallenius et al. 2002), which reported analogous demographic patterns of Norway spruce and Scots pine as a result of changing fire disturbance frequency, may indicate a relationship between recorded tree demography in the habitat class of coniferous and mixed coniferous forests with past fire occurrence. Furthermore, this could be a strong indication that this type of disturbance occurred at the scale of the entire forest area, rather than in individual tree stands. Similar to temperate forests in North America (Flatley et al. 2015), fire disturbance in Białowieża Forest could be a phenomenon occurring across a wide range of habitat conditions, from poor, dry habitats (Niklasson et al. 2010; Zin et al. 2015; Zin 2016) to rich forest communities (Spînu et al. 2020).

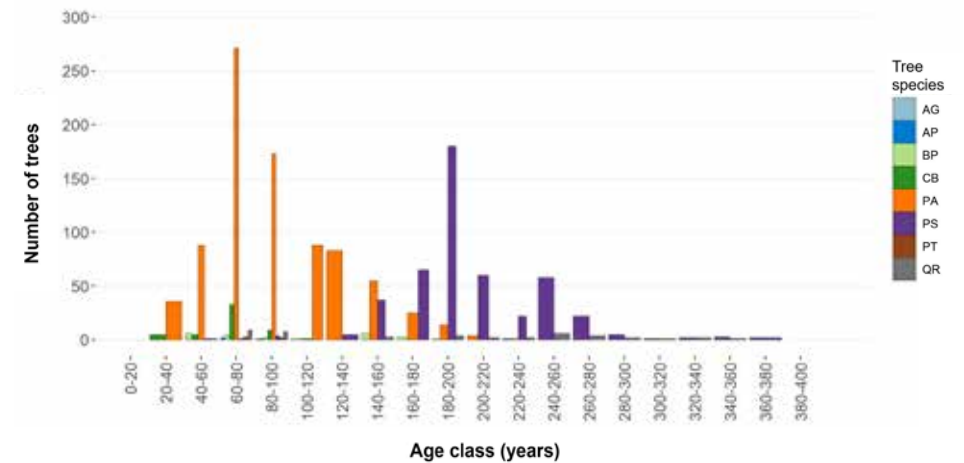

Figure 7.5. Age structure of the tree stands on dendrochronological study plots of the ForBioSensing project representing the habitat class of coniferous and mixed coniferous forests in the Polish part of Białowieża Forest (n=33). AG – *Alnus glutinosa*, black alder, AP – *Acer platanoides*, Norway maple, BP – *Betula pendula*, silver birch, CB – *Carpinus betulus*, common hornbeam, PA – *Picea abies*, Norway spruce, PS – *Pinus sylvestris*, Scots pine, PT – *Populus tremula*, aspen, QR – *Quercus robur*, pedunculate oak

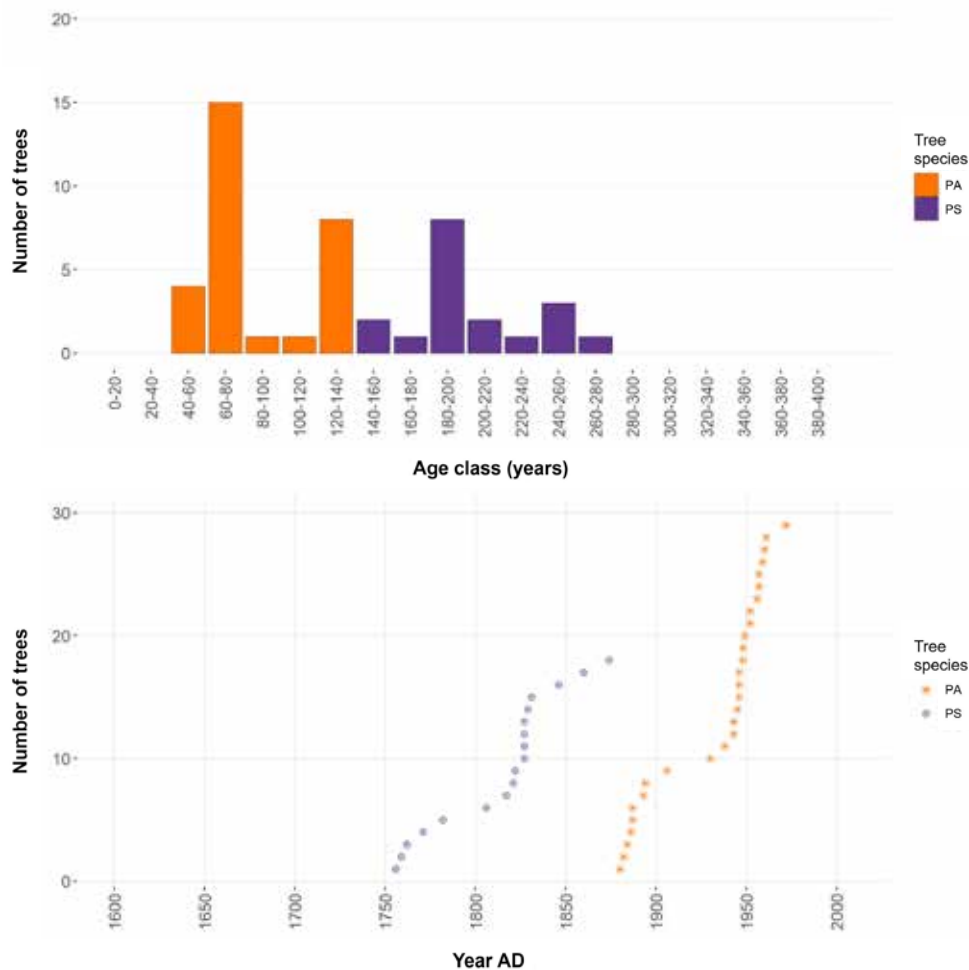

Figure 7.6. Age structure of a tree stand on a sample dendrochronological study plot of the ForBioSensing project representing the habitat class of coniferous and mixed coniferous forests in the Polish part of Białowieża Forest. PA – *Picea abies*, Norway spruce, PS – *Pinus sylvestris*, Scots pine. Upper diagram – age class distribution, lower diagram – cumulative germination years

Nine tree species were recorded in the habitat class of alder bog forests and riparian forests: black alder, common ash, Norway spruce, downy birch (*Betula pubescens* Ehrh.), common hornbeam, occasionally pedunculate oak, Norway maple, small-leaved lime, and Scots pine. The oldest tree generations were specimens in the age classes ranging from 260–280 to 320–340 years, dating from the 18th century and represented by ash, oak, and spruce. Single Norway maple trees were also found in the older generations, which are about 240 years old. Alder and hornbeam typically belonged to the younger generations, representing age classes ranging from 20–40 to 140–160 years. However, it is worth noting that the oldest generations of black alder, which represented age classes of 160–180 and 180–200 years, were from the mid-19th century (Fig. 7.7).

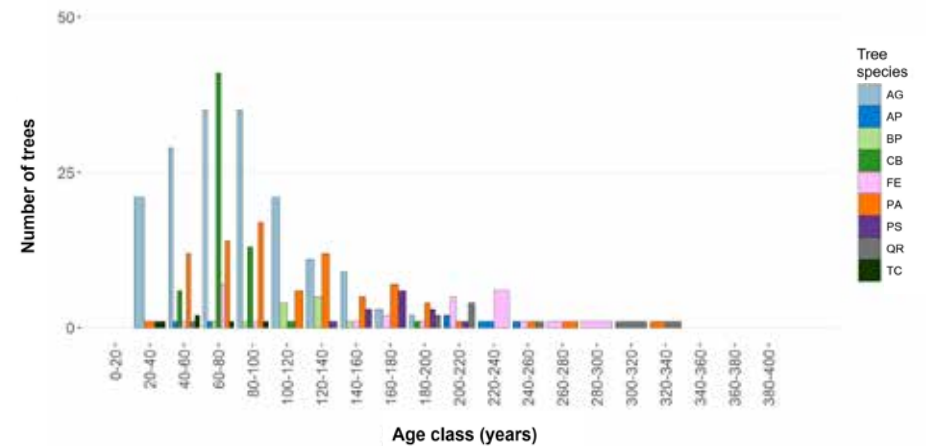

Figure 7.7. Age structure of the tree stands on dendrochronological study plots of the ForBioSensing project representing the habitat class of alder bog forests and riparian forests in the Polish part of Białowieża Forest (n=10). AG – *Alnus glutinosa*, black alder, AP – *Acer platanoides*, Norway maple, BP – *Betula pubescens*, downy birch, CB – *Carpinus betulus*, common hornbeam, FE – *Fraxinus excelsior*, common ash, PA – *Picea abies*, Norway spruce, PS – *Pinus sylvestris*, Scots pine, QR – *Quercus robur*, pedunculate oak, TC – *Tilia cordata*, small-leaved lime

In addition to the features described above, there is another feature that is characteristic of both the habitat class of coniferous and mixed coniferous forests and the habitat class of alder bog forests and riparian forests: the presence of common hornbeam in younger age classes (Fig. 7.5 and 7.7) in some study plots. The phenomenon of the spread of this species not only in deciduous and mixed deciduous forests, which are optimal for it (see Fig. 7.3–7.4), but also in other habitats, including much poorer ones, has been described in several studies based on data from permanent study plots in Białowieża Forest (e.g., Bernadzki et al. 1998; Sokołowski 1991, 2004; Kuijper et al. 2010b; Drozdowski et al. 2012; Paluch 2015; Brzeziecki et al. 2016, 2020; Gabrysiak et al. 2021). It is not straightforward to determine with certainty the cause of this process. The increasing proportion of this species could be the result of the disappearance of previous disturbances, such as fires, as shown in Białowieża Forest for a stand in an oak-lime-hornbeam forest (Spínu et al. 2020). Another possible cause is the influence of herbivorous ungulates, which, like fires, can act as a filter in shaping tree species composition (McEwan et al. 2014), allowing only some tree species, such as the browsing-tolerant hornbeam and lime, to regenerate successfully, as documented in the Białowieża National Park (Kuijper et al. 2010a). Another factor that could contribute to the spread of hornbeam, especially in oligotrophic habitats, is nitrogen deposition, which currently averages about 10–12 kg ha⁻¹ year⁻¹ in Białowieża Forest (Malzahn et al. 2009; Malzahn 2014). The resulting increase in habitat fertility (eutrophication) may lead to changes in species composition, and not only at the tree stand level (see e.g., Sokołowski 2004; Cholewińska et al. 2020). The spread of hornbeam may also be related to current climate change. Thermal and hydrological conditions in Białowieża Forest have changed significantly in recent decades. Reported changes include an increase in temperature, shorter periods of permanent snow cover, and more frequent droughts (Bernadzki et al. 1998; Malzahn et al.

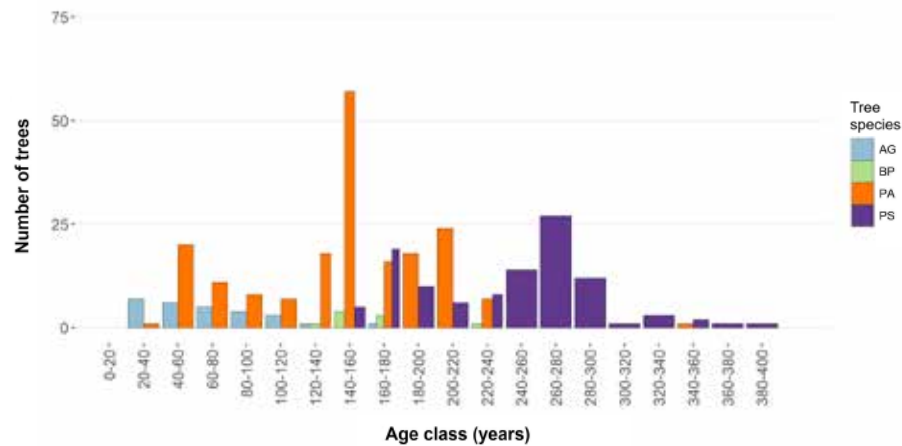

Figure 7.8. Age structure of the tree stands on dendrochronological study plots of the ForBioSensing project representing the habitat class of spruce bog forests in the Polish part of Białowieża Forest (n=7). AG – *Alnus glutinosa*, black alder, BP – *Betula pubescens*, downy birch, PA – *Picea abies*, Norway spruce, PS – *Pinus sylvestris*, Scots pine

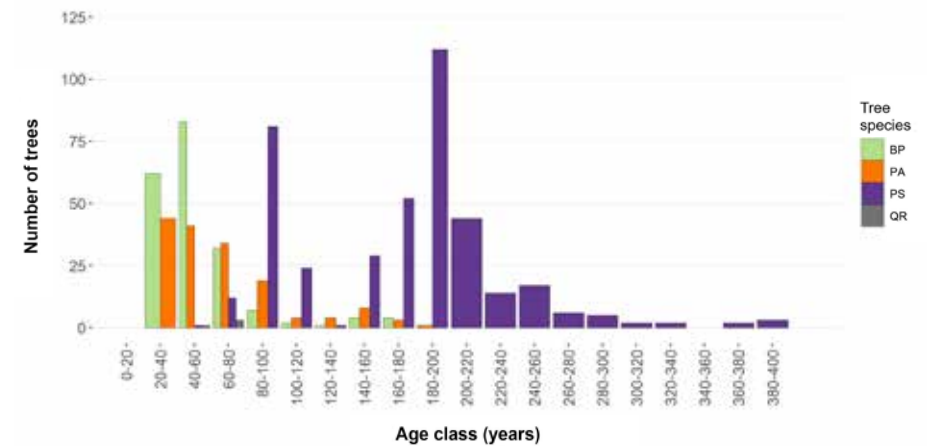

Figure 7.9. Age structure of the tree stands on dendrochronological study plots of the ForBioSensing project representing the habitat class of pine bog forests in the Polish part of Białowieża Forest (n=33). BP – *Betula pubescens*, downy birch, PA – *Picea abies*, Norway spruce, PS – *Pinus sylvestris*, Scots pine, QR – *Quercus robur*, pedunculate oak

2009; Boczoń et al. 2018). This can undoubtedly affect the competitive strength of individual tree species (Faliński 1986; Brzeziecki and Kienast 1994; Ellenberg 1996) and lead to changes in their proportion.

The lowest number of tree species (four) was observed in the study plots representing the habitat class of spruce bog forests, these include: Norway spruce, Scots pine, downy birch, and black alder. In the vast majority of the study plots, the oldest generations were represented by Scots pine. The oldest specimens found were pines in the 380–400 year age class, dating to the 17th century. Interestingly, the presence of similarly aged spruce populations, approximately 350 years old, was also noted, but this occurrence should undoubtedly be considered sporadic. As in the habitat class of coniferous and mixed coniferous forests, pine was represented by generations older than spruce, belonging to age classes ranging from 140–160 to 380–400 years, confirming the regeneration of this species from the first half of the 17th century to the second half of the 19th century. Spruce, on the other hand, belonged in most cases to the younger generation – generally to age classes ranging from 20–40 to 220–240 years, which indicated its regeneration in the period from the second half of the 18th century to the 20th century (with the exception mentioned above) (Fig. 7.8). For both tree species, the predominant mechanism of regeneration was cohort regeneration, as described above, clearly separated in time. The youngest tree generations in this habitat class were represented by alder and downy birch, which belonged to age classes ranging from 20–40 to 160–180 years, i.e., recruited since the second half of the 19th century (Fig. 7.8). The described demographic characteristics of spruce bog forests are consistent with the results of a 24-year study of vegetation dynamics conducted on permanent study plots in the „Wysokie Bagno” nature reserve (where one of the dendrochronological study plots of the ForBioSensing project was located, see Fig. 7.1). In the tree layer, only the older generations of pine were observed, which gradually decreased as this species did not regenerate, the proportion of alder increased, spruce re-

generated well, and birch remained as an admixture species. The cause of these changes was identified as eutrophication of the habitat, most likely caused in part by adverse changes in the local hydrology (in particular, the lowering of the groundwater level) as a result of drainage works in the immediate vicinity (Sokołowski 2004; see Yermokhin and Savel'ev 2011).

The same small number of tree species (four) as in the habitat class of spruce bog forests, was found in the habitat class of pine bog forests: Scots pine, Norway spruce, downy birch, and pedunculate oak. As in the habitat classes of spruce bog forests and coniferous and mixed coniferous forests, the oldest generations were represented by Scots pine. In addition, age class separation between pine and spruce was also observed here. The former species belonged to age classes ranging from 40–60 to 380–400 years, while the latter species belonged to age classes ranging from 20–40 to 180–200 years. The high proportion of pine in the 80–100 year age class was the result of mid-20th century regeneration cohorts present in some of the study plots. It is worth noting that this regeneration mechanism was the predominant type of tree regeneration found in this habitat class for all tree species found except oak. For pine, in addition to those already mentioned, there were 19th century regeneration cohorts represented by age classes ranging from 140–160 to 200–220 years. In most study plots, spruce and downy birch belonged to much younger generations represented by age classes ranging from 20–40 to 80–100 years, which were derived from 20th century regeneration cohorts. The described demographic patterns of the three main tree species occurring in the habitat class of pine bog forests may indicate changes in habitat fertility and hydrology (Sokołowski 2004; Yermokhin and Savel'ev 2011; Potapov et al. 2019). Interestingly, slightly older generations of spruce and birch were found in some study plots, belonging to age classes ranging from 100–120 to 160–180 years, which may indicate that the changes mentioned above occurred in some stands as early as the mid-19th century (Fig. 7.7).

7.3.2. Tree Response to Changing Climatic Conditions on the Example of Norway Spruce *Picea abies* (L.) Karst.

The residual chronology of Norway spruce from the selected study plot representing the habitat class of coniferous and mixed coniferous forests (EZ42_PA) is comparable in length to the vast majority of chronologies of this tree species from other sites in Białowieża Forest (Jaroszewicz 1993; Yermokhin and Savel'ev 2011; Yermokhin et al. 2010, 2017). However, it is still shorter than the longest chronology for this taxon and area, which dates back to the late 18th century (Koprowski and Zielski 2008). The spruce chronology of the studied plot was characterised by the predominance of negative pointer years over positive pointer years (7 and 4, respectively), with negative pointer years becoming more frequent in the period 1990–2010 (Fig. 7.10), which is also confirmed by other studies (Koprowski and Zielski 2008; Yermokhin and Savel'ev 2011). Comparison of negative pointer years for the period 1990–2010 with the values of standardised precipitation evapotranspiration indices for individual years made it possible to determine only 2000 as a year when extreme drought conditions (SPEI3 value < -2) were accompanied by the occurrence of a negative pointer year. Using *Superposed Epoch Analysis* (SEA) to show the significance of changes in indexed tree ring width in the three years before and three years after the onset of extreme drought did not reveal a clear negative growth response in the year with negative water balance. However, a significant decrease in radial growth was observed in the following three years after the extreme drought (Fig. 7.11). Interestingly, very strong drought-induced growth responses of small-leaved lime were also observed in Białowieża Forest in the analogous period – from the 1990s to the first years of the 21st century (Yermokhin et al. 2017).

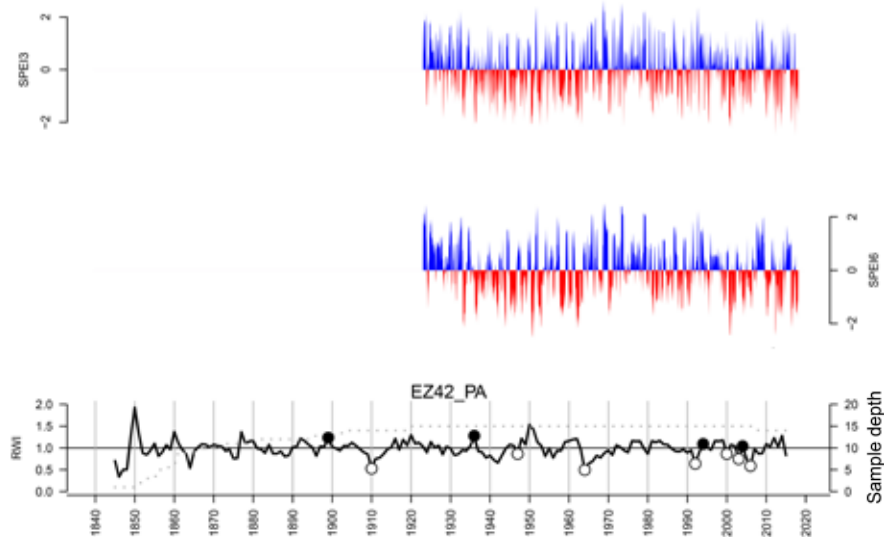

Figure 7.10. Time series of standardised precipitation evapotranspiration indices integrated over three (SPEI3) and six months (SPEI6), and Norway spruce site chronology for the dendrochronological study plot of the ForBioSensing project EZ42_PA representing the habitat class of coniferous and mixed coniferous forests (upper, middle, and lower panel, respectively). Negative and positive pointer years in the site chronology were marked (white and black circles, respectively). RWI – ring width index

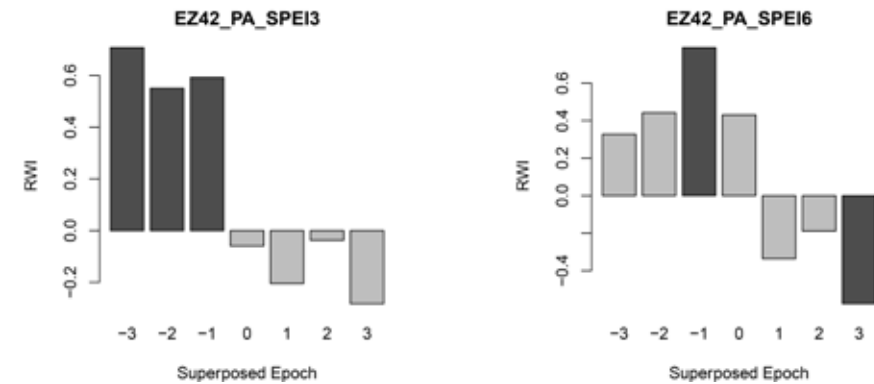

Figure 7.11. Bar diagrams for Norway spruce site chronology EZ42_PA in response to extreme drought, as determined by values of standardised precipitation evapotranspiration indices integrated over three (SPEI3) and six months (SPEI6) (SPEI3 – left panel, SPEI6 – right panel). Grey and dark grey bars indicate significance of changes in the indexed tree ring width ($p < 0.05$ and $p < 0.01$, respectively)

The most important climatic factors affecting radial growth of spruce in the selected study plot were spring temperature (late February–early April) and summer precipitation (June–July) (Fig. 7.12). At the same time, a positive effect of weather conditions preceding lateral meristem activity was observed, namely winter temperature and precipitation (November–January and December–January, respectively). In contrast, November precipitation of the previous year and temperatures in February and June had a negative effect on tree ring width. These results agree almost completely with the studies from the Belarusian part of Białowieża Forest, where a positive correlation of spruce growth with spring temperature (for different sites and studies: March; February–April) and summer precipitation (June–July; June–August) and a negative correlation with summer temperature (May–June; July) were also demonstrated. On the other hand, a positive effect of temperatures in September and October was reported for the period preceding the radial growth (Yermokhin and Savel'ev 2011; Yermokhin et al. 2017). Interestingly, the importance of precipitation for radial growth of Norway spruce in Białowieża Forest is emphasised in all dendroclimatic studies on this tree species (Koprowski and Zielski 2008; Yermokhin et al. 2010; Yermokhin and Savel'ev 2011; Yermokhin et al. 2017)

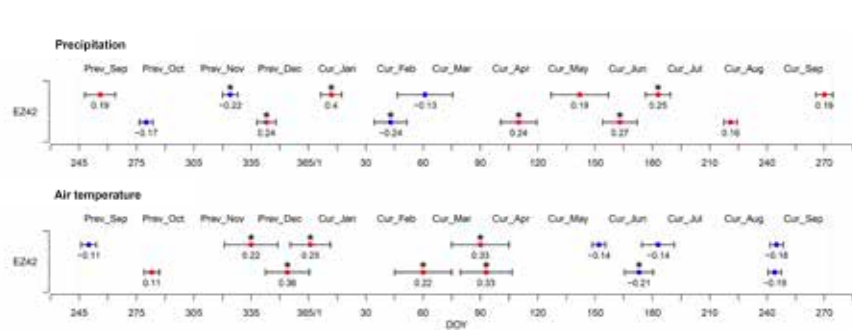

Figure 7.12. Climate sensitivity of Norway spruce, as determined on the basis of daily climate data. Correlations of the 7–30-day time window: between indexed tree ring width and precipitation (upper panel) and air temperature (lower panel) in the period from September of the previous year (Prev_Sep) to September of the current year (Cur_Sep). Red dots – positive correlations, blue dots – negative correlations, asterisks (*) indicate the correlation significance level ($p < 0.05$), horizontal whiskers indicate the length of the time window, the maximum value of the correlation coefficient is indicated under each whisker. DOY – day of year

The response of spruce growth to monthly values of climatic factors was characterised by temporal variability expressed in non-stationary correlations between indexed tree ring width and precipitation, air temperature, and drought indices. A positive influence of winter and spring temperatures was observed until the 1970s, after which the response to monthly air temperatures decreased (Fig. 7.13). This is most likely related to the increase in average air temperatures observed in recent decades, especially during the winter months (January–February) and early spring (March–April) (Malzahn et al. 2009; Yermokhin et al. 2010; Malzahn 2014). On the other hand, the influence of June precipitation, which was pronounced at the beginning of the studied period after weakening temporarily, was noticeable again in the last decade. Medium- and long-term droughts had a significant negative influence on spruce radial growth in the last decade (SPEI3 and SPEI6 positive correlation) (Fig. 7.13). This trend was mainly related to the negative water balance during summer (June–July) and fall and winter preceding radial growth (September–December of the previous year). This result is consistent with other studies from Białowieża Forest, which clearly showed the negative effects of both climate change in recent decades and drainage activities – mainly in the 20th-century (Yermokhin et al. 2010; Yermokhin and Savel'ev 2011). In addition, Norway spruce growth in Białowieża Forest is projected to decline by 20–30% by 2050 as a result of climate change (Yermokhin and Savel'ev 2011). In the long term, it is predicted that this tree species will only occur as a dominant understorey species and as an admixture in stands in the wettest areas, at the edges of wetlands, and in river valleys (Yermokhin et al. 2010). This may indicate that ongoing climate change, especially increasing temperatures and lengthening of the growing season, will not always and everywhere lead to increased growth of forest trees, including spruce (see Pretzsch et al. 2014).

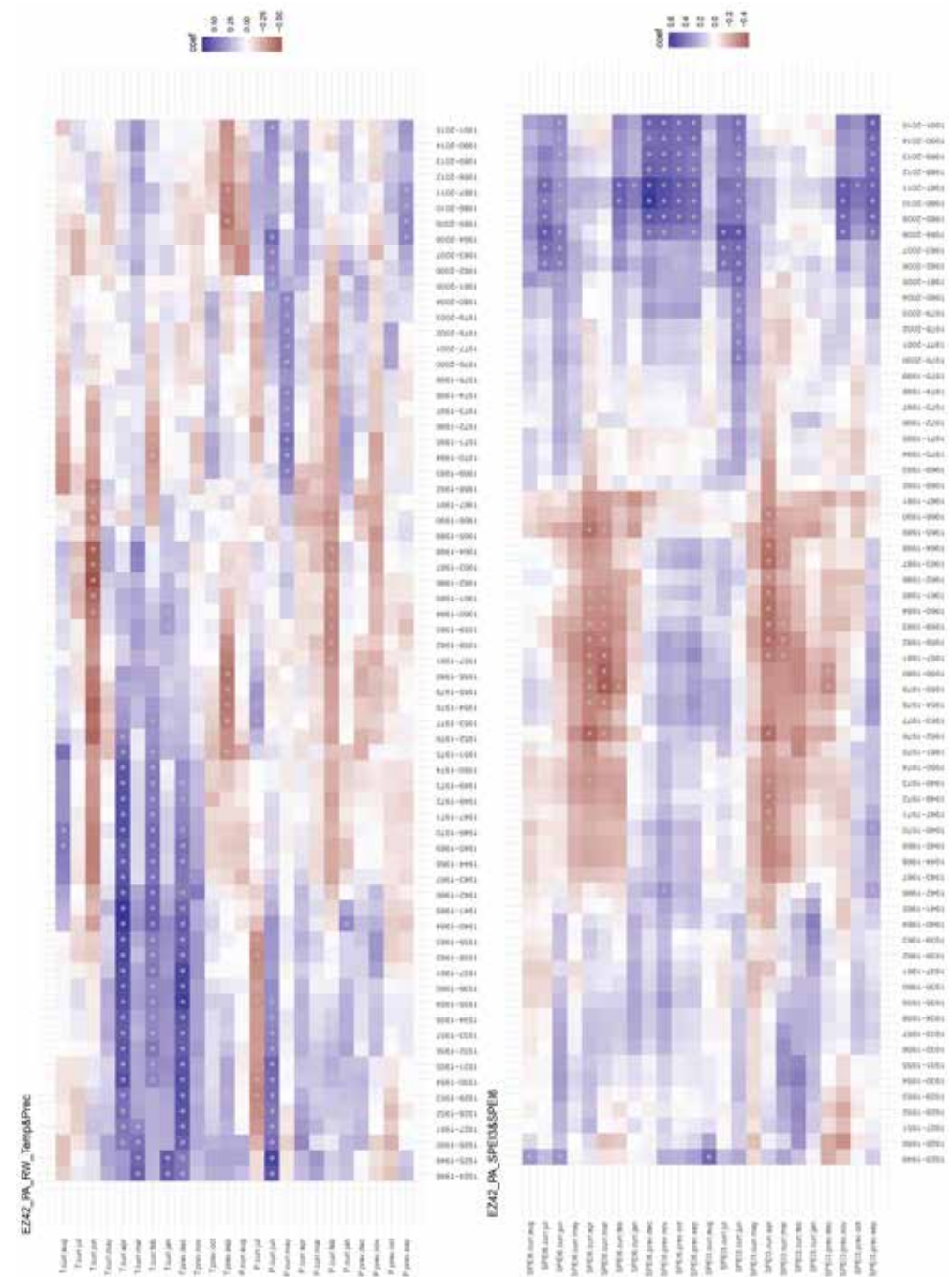

Figure 7.13. Correlations of a 25-year moving time window: between indexed ring width of Norway spruce and monthly precipitation (Prec, P), monthly mean air temperature (Temp, T) (upper panel), standardised precipitation evapotranspiration indices integrated over three (SPEI3) and six (SPEI6) months (lower panel). Correlations calculated for the period from September of the previous year (prev.sep) to August of the current year (curr.aug). Asterisks (*) indicate the correlation significance level ($p < 0.05$)

7.4. Conclusion

Undoubtedly, the research described in this chapter, conducted as part of the ForBio-Sensing project, has significantly increased the amount of existing empirical tree ring data from Białowieża Forest. To our knowledge, this is the largest dendrochronological material collected in this area to date. The reconstruction of long-term dynamics of selected tree stands, as well as the established master chronologies of the main tree species, contribute significantly to the knowledge of the history and long-term forest dynamics in the area, including the response of trees to changing climatic conditions, and provide better insight into the mechanisms that shape the regeneration dynamics of individual tree species in different habitats. However, for many species or forest communities for which there are no comparative data, either from Białowieża Forest or from other European forests, many questions must remain unanswered, which means that the need for dendrochronological research in this area is still high.

Acknowledgements

We thank the Regional Directorate for Environmental Protection in Białystok for permission to establish study plots and collect tree ring material in nature reserves. We are grateful to Mats Niklasson for valuable discussions during the initial phase of the research. We thank the following individuals for their assistance in collecting dendrochronological material in the field, preparing it for analysis and archiving, and creating and updating field and laboratory databases at various stages of the project during 2015–2020: Lander Amado, Raphaël Aussenac, Joanna Chęćka, Karolina Ciechańska-Sędłak, Alicja Dołkin, Krzysztof Gaszewski, Alicja Jasińska, Radosław Kanabus, Łukasz Kuberski, Grzegorz Ledworuch, Andrzej Lipiński, Paweł Nowak, Andoni Ortiz Garcia, Bartosz Piekło, Karol Rzeczycki, Rafał Sadkowski, Agata Sałachewicz, Paweł Sańczyk, Piotr Siwiec, Jakub Słowik, Krzysztof Sztabkowski, Adam Szulc, Krzysztof Szyłak, Ander Urdapilleta Iparraguirre, Adrian Wasiluk. Our special thanks go to Paweł Nowak for his understanding and invaluable support during the writing and editing phases of the manuscript.

References

- Aldrich S.R., Lafon, C.W., Grissino-Mayer H.D., De Weese G.G. & Hoss, J.A. 2010. Three centuries of fire in montane pine-oak stands on a temperate forest landscape. *Applied Vegetation Science*, 13: 36–46.
- Anchukaitis K.J., D'Arrigo R.D., Andreu-Hayles L., Frank, D., Verstege, A., Curtis, A., Buckley, B.M., Jacoby, G.C. & Cook, E.R. 2013. Tree-Ring-Reconstructed Summer Temperatures from Northwestern North America during the Last Nine Centuries. *Journal of Climate*, 26: 3001–3012. DOI: 10.1175/jcli-d-11-00139.1.
- Applequist M.B. 1958. A simple pith locator for use with off-centre increment cores. *Journal of Forestry*, 56: 141.
- Babst F., Poulter B., Bodesheim P., Mahecha M.D. & Frank D.C. 2017. Improved tree-ring archives will support earth-system science. *Nature Ecology & Evolution*, 1: 0008. DOI: 10.1038/s41559-016-0008.
- Babst F., Poulter B., Trouet V., Tan K., Neuwirth B., Wilson R., Carrer M., Grabner M., Tegel W., Levanić T., Panayotov M., Urbinati C., Bouriaud O., Ciais P. & Frank D. 2013. Site- and species-specific responses of forest growth to climate across the European continent. *Global Ecology and Biogeography*, 22: 706–717. DOI: 10.1111/geb.12023.
- Beguéría S., Vicente-Serrano S.M., Reig F. & Latorre B. 2014. Standardized precipitation evapotranspiration index (SPEI) revisited: parameter fitting, evapotranspiration models, tools, datasets and drought monitoring. *International Journal of Climatology*, 34: 3001–3023. DOI: 10.1002/joc.3887.
- Bernadzki E., Bolibok L., Brzeziecki B., Zajęzkowski J. & Żybura H. 1998. Compositional dynamics of natural forests in the Białowieża National Park, northeastern Poland. *Journal of Vegetation Science*, 9: 229–238. DOI: 10.2307/3237122.
- Bernadzki E., Brzeziecki B. & Rabczuk A. 2001. Raumzeitliche Dynamik des Durchmesserszuwachses in natürlichen Mischbeständen des Białowieża-Urwalds. *Beiträge für Forstwirtschaft und Landschaftökologie*, 35(4): 166–170.
- Bobiec A. 2012. Białowieża Primeval Forest as a remnant of culturally modified ancient forest. *European Journal of Forest Research*, 131: 1269–1285. DOI: 10.1007/s10342-012-0597-6.
- Bobiec A. & Bobiec M. 2012. Influence of spruce decline in stands of the Białowieża National Park on natural oak regeneration. *Sylvan*, 156: 243–251. DOI: 10.26202/sylvan.2011066.
- Bobiec A., Jaszcz E. & Wojtunik K. 2011a. Oak (*Quercus robur* L.) regeneration as a response to natural dynamics of stands in European hemiboreal zone. *European Journal of Forest Research*, 130: 785–797. DOI: 10.1007/s10342-010-0471-3.
- Bobiec A., Kuijper D.P.J., Niklasson M., Romankiewicz A. & Solecka K. 2011b. Oak (*Quercus robur* L.) regeneration in early successional woodlands grazed by wild ungulates in the absence of livestock. *Forest Ecology and Management*, 262: 780–790. DOI: 10.1016/j.foreco.2011.05.012.

- Boczoń A., Kowalska A., Ksepko M. & Sokołowski K. 2018. Climate Warming and Drought in the Białowieża Forest from 1950–2015 and Their Impact on the Dieback of Norway Spruce Stands. *Water* 10: 1502. DOI: 10.3390/w10111502.
- Brown P.M. & Wu R. 2005. Climate and disturbance forcing of episodic tree recruitment in a southwestern ponderosa pine landscape. *Ecology*, 86: 3030–3038. DOI: 10.1890/05-0034.
- Brzeziecki B., Drozdowski S., Bielak K., Czacharowski M., Zajączkowski J., Buraczyk W. & Gawron L. 2021. A demographic equilibrium approach to stocking control in mixed, multiaged stands in Białowieża Forest, northeast Poland. *Forest Ecology and Management*, 481: 118694. DOI: 10.1016/j.foreco.2020.118694.
- Brzeziecki B. & Kienast F. 1994. Classifying the Life-History Strategies of Trees on the Basis of the Grimian Model. *Forest Ecology and Management*, 69: 167–187. DOI: 10.1016/0378-1127(94)90227-5.
- Brzeziecki B., Pommerening A., Miścicki S., Drozdowski S. & Żybura H. 2016. A common lack of demographic equilibrium among tree species in Białowieża National Park (NE Poland): evidence from long-term plots. *Journal of Vegetation Science*, 27: 460–467. DOI: 10.1111/jvs.12369.
- Brzeziecki B., Woods K., Bolibok L., Zajączkowski J., Drozdowski S., Bielak K. & Żybura H. 2020. Over 80 years without major disturbance, late-successional Białowieża woodlands exhibit complex dynamism, with coherent compositional shifts towards true old-growth conditions. *Journal of Ecology*, 108: 1138–1154. DOI: 10.1111/1365-2745.13367.
- Cholewińska O., Adamowski W. & Jaroszewicz B. 2020. Homogenization of Temperate Mixed Deciduous Forests in Białowieża Forest: Similar Communities Are Becoming More Similar. *Forests* 11: 545. DOI: 10.3390/f11050545.
- Chree C. 1914. Some Phenomena of Sunspots and of Terrestrial Magnetism. Part II. *Philosophical Transactions of the Royal Society of London. Series A, Containing Papers of a Mathematical or Physical Character*, 213: 245–277.
- Cook E.R. & Peters K. 1981. The smoothing spline: a new approach to standardizing forest interior tree-ring width series for dendroclimatic studies. *Tree-Ring Bulletin*, 41: 45–53.
- Cornes R.C., van der Schrier G., van den Besselaar E.J. & Jones P.D. 2018. An ensemble version of the E-OBS temperature and precipitation data sets. *Journal of Geophysical Research: Atmospheres*, 123: 9391–9409. DOI: 10.1029/2017JD028200.
- Cropper J.P. 1979. Tree-ring skeleton plotting by computer. *Tree-Ring Bulletin*, 39: 47–60.
- Demidko D.A., Trefilova O.V., Kulakov S.S. & Mikhaylov P.V. 2021. Pine Looper *Bupalus piniaria* (L.) Outbreaks Reconstruction: A Case Study for Southern Siberia. *Insects*, 12: 90. DOI: 10.3390/insects12020090.
- Drozdowski S., Brzeziecki B., Żybura H., Żybura B., Gawron L., Buraczyk W., Zajączkowski J., Bolibok L., Szeligowski H., Bielak K., Widawska Z. 2012. Wieloletnia dynamika starodrzewów w zagospodarowanej części Puszczy Białowieskiej: gatunki ekspansywne i ustępujące. [Long-term dynamics of old-growth stands in the managed part of the Białowieża Forest: increasing and declining tree species.] *Sylwan*, 156(9): 663–671. DOI: 10.26202/sylwan.2012016.
- Ellenberg H. 1996. *Vegetation Mitteleuropas mit den Alpen*. 5. Auflage. Ulmer, Stuttgart.
- Faliński J.B. 1986. *Vegetation Dynamics in Temperate Lowland Primeval Forest*. Ecological Studies in Białowieża Forest. Dr W. Junk Publishers, Dordrecht.
- Flatley W.T., Lafon, C.W., Grissino-Mayer H.D. & LaForest L.B. 2015. Changing fire regimes and old-growth forest succession along a topographic gradient in the Great Smoky Mountains. *Forest Ecology and Management*, 350: 96–106. DOI: 10.1016/j.foreco.2015.04.024.
- Fraver S., Seymour R.S., Speer J.H. & White A.S. 2007. Dendrochronological reconstruction of spruce budworm outbreaks in northern Maine, USA. *Canadian Journal of Forest Research*, 37: 523–529.
- Gabrysiak K.A., Paluch R. & Gawryś R. 2021. 30-Year Changes in Oak-Hornbeam Forest after Windthrow. *Forests*, 12: 600. DOI: 10.3390/f12050600.
- Gutowski J.M. & Jaroszewicz B. 2004. Białowieża Primeval Forest as a refuge of the European entomofauna. *Wiadomości Entomologiczne*, 23 Supl. 2: 67–87.
- Heyerdahl E.K., Loehman R.A. & Falk D.A. 2014. Mixed-severity fire in lodgepole pine dominated forests: are historical regimes sustainable on Oregon's Pumice Plateau, USA? *Canadian Journal of Forest Research*, 44: 593–603. DOI: 10.1139/cjfr-2013-0413.
- Jaroszewicz B. 1993. Stopień podobieństwa krzywych dendrochronologicznych (telekoneksja) między świerkami z Puszczy Białowieskiej i z Babiej Góry. [Degree of similarity of dendrochronological curves (teleconnection) between spruces from Białowieża Forest and Babia Góra.] *Parki Narodowe i Rezerваты Przyrody*, 12: 13–19.
- Jaroszewicz B., Cholewińska O., Gutowski J.M., Samojlik T., Zimny M. & Latałowa M. 2019. Białowieża Forest—A Relic of the High Naturalness of European Forests. *Forests*, 10: 849. DOI: 10.3390/f10100849.
- Jevšenak J. & Levanič, T. 2018. *dendroTools*: R package for studying linear and nonlinear responses between tree-rings and daily environmental data. *Dendrochronologia* 48: 32–39. DOI: 10.1016/j.dendro.2018.01.005.
- Jędrzejewska B. & Jędrzejewski W. 1998. *Predation in Vertebrate Communities. The Białowieża Primeval Forest as a Case Study*. Springer, Berlin – Heidelberg – New York.
- Jędrzejewska B., Jędrzejewski W., Bunevich A.N., Miłkowski L. & Krasieński Z.A. 1997. Factors shaping population densities and increase rates of ungulates in Białowieża Primeval Forest (Poland and Belarus) in the 19th and 20th centuries. *Acta Theriologica*, 42: 399–451.

- Koprowski M. & Zielski A. 2008. Extremely narrow and wide tree rings in the Norway spruce (*Picea abies* (L.) Karst.) of the Białowieża National Park. *Ecological questions*, 9: 73–78. DOI: 10.2478/v10090-009-0021-0.
- Korczyk A.F. 1994. The oldest trees from Białowieża Primeval Forest. 1. Scots pine (*Pinus sylvestris* L.). *Rocznik Dendrologiczny*, 42: 131–143.
- Kuijper D.P.J., Cromsigt J.P.G.M., Jędrzejewska B., Miścicki S., Churski M., Jędrzejewski W. & Kweczlich I. 2010a. Bottom-up versus top-down control of tree regeneration in the Białowieża Primeval Forest, Poland. *Journal of Ecology*, 98: 888–899. DOI: 10.1111/j.1365-2745.2010.01656.x.
- Kuijper D.P.J., Jędrzejewska B., Brzeziecki B., Churski M., Jędrzejewski W. & Żybura H. 2010b. Fluctuating ungulate density shapes tree recruitment in natural stands of the Białowieża Primeval Forest, Poland. *Journal of Vegetation Science*, 21: 1082–1098. DOI: 10.1111/j.1654-1103.2010.01217.x.
- Kullman L. 2002. Boreal tree taxa in the central Scandes during the Late-Glacial: implications for Late-Quaternary forest history. *Journal of Biogeography*, 29: 1117–1124. DOI: 10.1046/j.1365-2699.2002.00743.x.
- Lafon C.W., Naito A.T., Grissino-Mayer H.D., Horn S.P. & Waldrop T.A. 2017. Fire history of the Appalachian region: a review and synthesis. U. S. Department of Agriculture, Forest Service, Southern Research Station, Asheville, NC.
- Leuschner C. & Ellenberg H. 2017. *Ecology of Central European Forests: Vegetation Ecology of Central Europe*, Volume I. Springer International Publishing, Cham.
- Li M., Shao X., Yin Z.-Y. & Xu X. 2015. Tree-Ring Dating of the Reshui-1 Tomb in Dulan County, Qinghai Province, North-West China. *Plos One* 10: e0133438. DOI: 10.1371/journal.pone.0133438.
- Malik I., Poreba G., Wistuba M. & Woskowicz-Ślęzak B. Combining 137Cs, 210Pb and dendrochronology for improved reconstruction of erosion–sedimentation events in a loess gully system (southern Poland). *Land Degradation & Development*, 32: 2336–2350. DOI: 10.1002/ldr.3903.
- Malzahn E. 2014. Zmiany warunków klimatycznych i wodnych w środowisku lasów naturalnych Puszczy Białowieskiej BLP-361. [Changes in climate and water conditions in the natural forest environment of Białowieża Forest BLP-361.] *Sprawozdanie końcowe. [Final Report.]* Instytut Badawczy Leśnictwa, Sękocin Stary.
- Malzahn E., Kwiatkowski W. & Pierzgalski E. 2009. *Przyroda nieożywiona*. [In:] Okołów, C., Karaś, M. & Bołbot, A. (eds.) *Białowieski Park Narodowy. Poznać – Zrozumieć – Zachować. [Białowieża National Park. Know it – Understand it – Protect it.]*, pp. 17–36. Białowieski Park Narodowy, Białowieża.
- Matuszkiewicz J.M. (ed.) 2007. *Geobotaniczne rozpoznanie tendencji rozwojowych zbiorowisk leśnych w wybranych regionach Polski. [Geobotanical identification of developmental trends of forest communities in selected regions of Poland.]* Instytut Geografii i Przestrzennego Zagospodarowania im. Stanisława Leszczyckiego PAN, Warszawa.
- McEwan R.W., Pederson N., Cooper A., Taylor J., Watts R. & Hruska A. 2014. Fire and gap dynamics over 300 years in an old-growth temperate forest. *Applied Vegetation Science*, 17: 312–322. DOI: 10.1111/avsc.12060.
- McKee T.B., Doesken N.J. & Kleist J. 1993. The relationship of drought frequency and duration to time scales. [In:] *Proceedings of the 8th Conference on Applied Climatology: 179–183*. American Meteorological Society, Boston.
- Niklasson M. 2002. A comparison of three age determination methods for suppressed Norway spruce: implications for age structure analysis. *Forest Ecology and Management*, 161: 279–288. DOI: 10.1016/S0378-1127(01)00500-X.
- Niklasson M. & Drakenberg B. 2001. A 600-year tree-ring fire history from Norra Kvills National Park, southern Sweden: implications for conservation strategies in the hemiboreal zone. *Biological Conservation*, 101: 63–71. DOI: 10.1016/S0006-3207(01)00050-7.
- Niklasson M. & Granström A. 2000. Numbers and sizes of fires: Long-term spatially explicit fire history in a Swedish boreal landscape. *Ecology*, 81: 1484–1499. DOI: 10.2307/177301.
- Niklasson M., Zin E., Zielonka T., Feijen M., Korczyk A.F., Churski M., Samojlik T., Jędrzejewska B., Gutowski J.M. & Brzeziecki, B. 2010. A 350-year tree-ring fire record from Białowieża Primeval Forest, Poland: implications for Central European lowland fire history. *Journal of Ecology*, 98: 1319–1329. DOI: 10.1111/j.1365-2745.2010.01710.x.
- Nowacki G.J. & Abrams M.D. 2008. The demise of fire and “Mesophication” of forests in the eastern United States. *Bioscience*, 58: 123–138. DOI: 10.1641/b580207.
- Paluch R. 2005. Odnowienie naturalne dębu w Leśnym Kompleksie Promocyjnym „Puszcza Białowieska” – stan, warunki i perspektywy. [Natural regeneration of oak in the „Białowieża Primeval Forest” Promotional Forest Complex – state, conditions and prospects.] *Sylvan*, 149(1): 30–41. DOI: 10.26202/sylvan.2004063.
- Paluch R. 2015. Wieloletnie zmiany składu gatunkowego drzewostanów naturalnych w Puszczy Białowieskiej. [Long-term changes in the species composition of natural stands in Białowieża Forest.] *Sylvan*, 159(4): 278–288. DOI: 10.26202/sylvan.2014083.
- Paulo A., Rosa R. & Pereira L. 2012. Climate trends and behaviour of drought indices based on precipitation and evapotranspiration in Portugal. *Natural Hazards and Earth System Sciences*, 12: 1481–1491. DOI: 10.5194/NHESS-12-1481-2012.
- Peterken G.F. 1996. *Natural Woodland: Ecology and Conservation in Northern Temperate Regions*. Cambridge University Press, Cambridge.
- Potapov A., Toomik S., Yermokhin M., Edvardsson J., Lilleleht A., Kiviste A., Kaart T., Metslaid S., Järvet A. & Hordo M. 2019. Synchronous Growth Releases in Peatland Pine Chronologies as an Indicator for Regional Climate Dynamics—A Multi-Site Study Including Estonia, Belarus and Sweden. *Forests*, 10: 1097. DOI: 10.3390/f10121097.

- Pretzsch H., Biber P., Schütze G., Uhl E., & Rötzer T. 2014. Forest stand growth dynamics in Central Europe have accelerated since 1870. *Nature Communications*, 5: 4967. DOI: 10.1038/ncomms5967.
- R Core Team 2018. R: A language and environment for statistical computing. R Foundation for Statistical Computing, Vienna, Austria.
- Schweingruber F.H., Eckstein D., Serre-Bachet F. & Bräker O.U. 1990. Identification, presentation and interpretation of event years and pointer years in dendrochronology. *Dendrochronologia*, 8: 9–39.
- Smit C., Kuijper D.P.J., Prentice D., Wassen M.J. & Cromsigt J.P.G.M. 2012. Coarse woody debris facilitates oak recruitment in Białowieża Primeval Forest, Poland. *Forest Ecology and Management*, 284: 133–141. DOI: 10.1016/j.foreco.2012.07.052.
- Sokołowski A.W. 1991. Changes in species composition of forest associations in the nature reserves of the Białowieża Forest. *Ochrona Przyrody*, 49: 63–78.
- Sokołowski A.W. 2004. *Lasy Puszczy Białowieskiej*. Centrum Informacyjne Lasów Państwowych, Warszawa.
- Sokołowski A.W. 1999. Succession of forest communities in the Starzyna reserve in the Białowieża Forest. *Parki Narodowe i Rezerваты Przyrody*, 18: 31–59.
- Speer J.H. 2010. *Fundamentals of tree-ring research*. The University of Arizona Press, Tucson.
- Spínu A.P., Niklasson M. & Zin E. 2020. Mesophication in temperate Europe: A dendrochronological reconstruction of tree succession and fires in a mixed deciduous stand in Białowieża Forest. *Ecology and Evolution*, 10: 1029–1041. DOI: 10.1002/ece3.5966.
- Stokes M.A. & Smiley T.L. 1968. *An Introduction to Tree-Ring Dating*. University of Chicago Press, Chicago.
- van der Maaten-Theunissen M., van der Maaten E. & Bouriaud O. 2015. pointRes: an R package to analyze pointer years and components of resilience. *Dendrochronologia*, 35: 34–38. DOI: 10.1016/j.dendro.2015.05.006.
- van Ginkel H.A.L., Kuijper D.P.J., Churski M., Zub K., Szafrńska P. & Smit C. 2013. Safe for saplings not safe for seeds: *Quercus robur* recruitment in relation to coarse woody debris in Białowieża Primeval Forest, Poland. *Forest Ecology and Management*, 304: 73–79. DOI: 10.1016/j.foreco.2013.04.037.
- Vera F. 2000. *Grazing Ecology and Forest History*. CABI Publishing, Wallingford, The Netherlands.
- Vicente-Serrano S.M., Beguería S. & López-Moreno J.I. 2010. A multiscalar drought index sensitive to global warming: the standardized precipitation evapotranspiration index. *Journal of climate* 23, 1696–1718. DOI: 10.1175/2009JCLI2909.1.
- Wallenius T., Kuuluvainen T., Heikkilä R. & Lindholm T. 2002. Spatial tree age structure and fire history in two old-growth forests in eastern Fennoscandia. *Silva Fennica*, 36: 185–199.
- Yamaguchi D.K. 1991. A Simple Method for Cross-Dating Increment Cores from Living Trees. *Canadian Journal of Forest Research*, 21: 414–416. DOI: 10.1139/X91-053.
- Yermokhin M.V., Barsukova V.E., Knysh N.V., Mychko V.E. & Bernackii D.I. 2016. Dinamika i sostoyanie populjacji pikhty beloi v urochishche Tisovik. *Belovezhskaya Pushcha. Issledovaniya*, 14: 65–88.
- Yermokhin M.V., Mychko V.E., Knysh N.V. & Lukin V.V. 2017. Rekonstrukciya dinamiki vysokovozrastnykh shirokolistvennykh lesov Belovezhskoi Pushchi. *Botanika*, 6: 67–83.
- Yermokhin M.V., Pugachevskii A.V., Savel'ev V.V. & Gerasimovich A.G. 2010. Rol' klimaticheskikh izmenenii i osushite'noi melioracii v dinamike lesnykh ekosistem nacional'nogo parka „Belovezhskaya Pushcha”. [In:] *Belovezhskaya Pushcha: istoriya, priroda, turizm*: 202–213.
- Yermokhin, M.V. & Savel'ev, V.V. 2011. Vliyanie klimaticheskikh faktorov na radial'nyi prirost derev'ev sosny, eli i duba v Belovezhskoi Pushche. [In:] *Osobo okhranyaemye prirodnye territorii Belarusi*: 28–44. Belorusskii Dom pečati, Minsk.
- Zang C. & Biondi F. 2015. treeclim: an R package for the numerical calibration of proxy-climate relationships. *Ecography*, 38: 431–436. DOI: 10.1111/ecog.01335.
- Ząbek J. & Zaręba R. 1957. Najstarsze świerki w Puszczy Białowieskiej. [The oldest spruces in Białowieża Forest.] *Sylwan*, 101(5): 46–58.
- Zielonka T., Holeksa J., Fleischer P. & Kapusta P. 2010. A tree-ring reconstruction of wind disturbances in a forest of the Slovakian Tatra Mountains, Western Carpathians. *Journal of Vegetation Science*, 21: 31–42. DOI: 10.1111/j.1654-1103.2009.01121.x.
- Zielski A. & Krąpiec M. 2004. *Dendrochronologia*. Wydawnictwo Naukowe PWN, Warszawa.
- Zin E. 2016. Fire history and tree population dynamics in Białowieża Forest, Poland and Belarus. PhD, Swedish University of Agricultural Sciences.
- Zin E., Drobyshev I., Bernacki D. & Niklasson M. 2015. Dendrochronological reconstruction reveals a mixed-intensity fire regime in *Pinus sylvestris*-dominated stands of Białowieża Forest, Belarus and Poland. *Journal of Vegetation Science*, 26: 934–945. DOI: 10.1111/jvs.12290.

8. Current tree growth in Białowieża Forest – stem circumference changes recorded by dendrometers during the 2016–2020 period

Ewa Zin¹, Agata Salachewicz¹, Marcin Klisz², Krzysztof Szylak¹,
Łukasz Kuberski¹, Kamil Pilch¹

¹ Forest Research Institute, Department of Natural Forests, 6 Park Dyrekcyjny St., 17-230 Białowieża

² Forest Research Institute, Department of Silviculture and Genetics, Sękocin Stary,

3 Braci Leśnej St., 05-090 Raszyn

{e.zin, a.salachewicz, m.klisz, k.szylak, l.kuberski, k.pilch}@ibles.waw.pl

Abstract

Radial growth of trees depends on many factors. Automatic dendrometers are one of the tools that can be used to study this phenomenon. These are devices that record, with high temporal resolution, the changes in tree stem volume, both the irreversible growth of stem volume due to wood formation by cell division and growth, and the reversible shrinkage and swelling of stems caused by variations in water content in the wood. The main goal of the research with dendrometers within the ForBioSensing project was to increase the knowledge about the current radial growth of the main tree species of Białowieża Forest under different habitat conditions. The aim of this chapter is to demonstrate the potential of dendrometer data for determining stem circumference changes of selected tree species in different habitats of Białowieża Forest during the 2016–2020 period. Meteorological conditions in Białowieża Forest in the studied period were characterised in comparison with long-term average values (1951–2020). Selected tree species in the main habitat types of Białowieża Forest responded to the diverse meteorological conditions in the period 2016–2020 with different stem circumference changes. During this period, there were both significant anomalies in meteorological conditions (2018–2020) and more average conditions (2016–2017). The highest stem circumference growth during 2016–2020 was recorded for elm in oak-lime-hornbeam forests. Most tree taxa showed the highest stem circumference growth during the 2017 meteorological growing season. The obtained results may indicate certain trends. However, long-term meteorological and dendrometric observations are needed to confirm these trends, because long-term empirical data greatly increase the chance of detecting regularities in tree response to environmental conditions.

Keywords: radial growth, meteorological conditions, climate change

8.1. Introduction

Tree growth depends on many factors, including climatic conditions, biocenotic relationships, genetic characteristics of a specimen and species, biotic factors such as insect outbreaks, and abiotic factors such as droughts. The critical role in growth is usually played

by the factor that is insufficient (Fritts 1976), which means that tree growth is primarily controlled by limiting factors. Removal of a limiting factor (e.g., insufficient temperature, lack of precipitation) leads to increased growth until another factor inhibits the process (Downes et al. 1999).

One of the tools commonly used to study the current radial tree growth, are automatic dendrometers, which record changes in stem volume with very high temporal resolution (Deslauriers et al. 2003; Rossi et al. 2006; van der Maaten et al. 2013; Herrmann et al. 2016; Nalevanková et al. 2018; Klisz et al. 2020; Salomón et al. 2022). These changes consist of two processes, one permanent and the other reversible. The permanent change, called radial growth, is caused by the annual deposition of new wood cells and their growth, while the non-permanent change results from fluctuations in the amount of water in the phloem, which cause reversible changes in stem volume (Deslauriers et al. 2007a; Korpela et al. 2008; Nalevanková et al. 2018).

The process of reversible changes in stem volume, which occurs in both seasonal and diurnal cycles, consists of tissue swelling and shrinking (Deslauriers et al. 2003; Mäkinen et al. 2008). During winter frosts, the water in the living cells (cambium, phloem) migrates into the wood and causes significant shrinkage (i.e., decrease) of the stem circumference. The water in the wood has a higher freezing point than the water in the phloem, which causes the water in the wood to freeze quickly. This in turn leads to a decrease in the water potential in the wood. It is replenished by the water previously contained in the living cells mentioned above. Its movement into the wood causes the cells to shrink and the stem circumference to decrease. This mechanism is aimed at protecting the living cells from frost damage. During the thaw, when the water frozen in the xylem melts, the water potential in the wood becomes higher than in the living cells, causing water from the wood to enter the living cells, leading to their swelling and increasing the stem circumference (Zweifel and Häsler 2000). This phenomenon occurs on a large scale in spring, when the phloem and cambium soak up water before radial growth begins (Turcotte et al. 2009). The swelling of tree stems in summer is caused by a slowing of transpiration under high air humidity conditions induced, for example, by precipitation (Herzog et al. 1995). The mechanism of diurnal stem volume change, consisting of shrinkage during the day and swelling during the night, is also due to water transport between tissues. This mechanism has been shown to be related to transpiration. The water potential in the xylem decreases as a result of transpiration, causing water to flow from the phloem into the wood, while the elastic tissues (cambium, phloem, parenchyma) can be considered as a specific water reservoir (e.g., Dobbs and Scott 1971; Herzog et al. 1995; Zweifel et al. 2000; Turcotte et al. 2011). However, there are also studies suggesting that there is no relationship between the mechanism of diurnal stem volume changes and transpiration, where these changes were found even after the removal of the entire assimilative apparatus. This study showed that the diurnal changes in stem volume were related to the variation in relative humidity at the stem surface, reflecting the hygroscopic properties of the bark (Lövdahl and Odén 1992).

Weather factors can explain more than half of the reversible variation in stem circumference (Downes et al. 1999; van der Maaten et al. 2013), both seasonal and diurnal. Existing studies refer to such key factors as precipitation or its absence, i.e., droughts, changes

in mean and maximum air temperature, soil water content (Herzog et al. 1995; Downes et al. 1999; Deslauriers et al. 2003; Turcotte et al. 2011; King et al. 2013; van der Maaten et al. 2013; Vieira et al. 2013; Nalevanková et al. 2018). It should be noted that trees respond to changing weather conditions with a time lag, and its inclusion in the study increases the strength of the correlation between radial growth and weather conditions (Downes et al. 1999; van der Maaten et al. 2013).

Dendrometers record both types of stem circumference changes described above, i.e., both the irreversible increase in circumference due to wood formation by cell division and growth, and the reversible stem shrinkage and swelling caused by changing water content in the wood. Therefore, data on current radial tree growth provided by dendrometers should be interpreted with caution (Deslauriers et al. 2007b). The onset of stem circumference increase recorded by a dendrometer may be more than 20 days earlier than the onset of wood formation determined by micro-coring and pinning, i.e., inserting a thin needle into the tree to damage the cambium and observing at what point in the tree ring the cells change appearance and a scar forms. On the other hand, the end of stem circumference changes recorded with dendrometers may be a week later than the end of wood cell growth (Mäkinen et al. 2008). Furthermore, the early observation of an increase in stem circumference may actually be due to the flow of water into the cambium and phloem in the spring (Deslauriers et al. 2003; Turcotte et al. 2009). Despite the above considerations that must be taken into account when interpreting the results, there is no doubt that dendrometers provide valuable data for understanding the mechanisms that control changes in stem circumference and radial tree growth, including the influence of certain environmental factors (van der Maaten et al. 2013).

Temperature and photoperiodism are crucial for the process of xylogenesis. Temperature influences metabolic activity during cambium cell division and xylem cell differentiation, while photoperiod determines the timing of maximum radial growth (Rossi et al. 2006; Ježik et al. 2016). Thus, climatic and meteorological conditions are among the most important factors affecting this process (Fritts 1976). Numerous signs of stress and weakening of trees have been observed in recent years, which have been characterised by strong fluctuations in climatic conditions (e.g., Allen et al. 2010; Anderegg et al. 2015). Projections for Europe predict a continuation of current climate change trends, with an increase in mean air temperature, changes in precipitation, a decrease in cloud cover, a shortening of the duration of snow cover, a decrease in soil water content, and a significant increase in the frequency and intensity of extreme weather phenomena such as floods and droughts (Giorgi et al. 2004; Zajączkowski et al. 2013). It should be added that these changes are likely to be characterised by significant regional variations (Giorgi et al. 2004). For the Białowieża Forest climate zone, the IPCC (Intergovernmental Panel on Climate Change) predicts that by the end of the 21st century the average annual temperature will increase by 2–3°C in spring and 3–4°C in other seasons. Precipitation distribution will change throughout the year, with total precipitation decreasing by about 10% in summer and increasing by a similar amount in winter. These changes will also be accompanied by other phenomena, such as a shortening of the duration of snow cover, an increase in wind speed, and a decrease in cloud cover (IPCC 2007). The response of trees to these changes, which are so complex and multidirectional, is likely to be equally complex.

Consequently, the analysis of the relationship between the meteorological conditions and tree growth is a very important issue. It is well known that the degree of correlation between meteorological conditions and stem circumference growth varies throughout the year (Downes et al. 1999; van der Maaten et al. 2013). In the study on common beech (*Fagus sylvatica* L.) a positive correlation of tree growth with air temperature was observed at the beginning of the year. From the beginning of July, the correlation between temperature and growth began to decrease and even reached negative values. At the same time, the correlation of growth with precipitation started to increase (van der Maaten et al. 2013). Similar results were obtained in a study on a North and Central American pine species, *Pinus hartwegii* Lindl. This study showed that radial growth was most strongly correlated with temperature (especially soil temperature) and solar radiation in late spring (April–May), while it was correlated with humidity and precipitation in early summer (June–July). In late summer, the correlation with meteorological factors was more diverse (Biondi and Hartsough 2010). Since meteorological factors have such a significant influence on radial growth of trees, it seems crucial to include meteorological data in the analysis of this process, especially to allow a more complete interpretation of the results obtained and possible future modelling of tree growth (Korpela et al. 2008).

The main goal of the research with dendrometers conducted within the ForBioSensing project was to increase the knowledge about the current growth of the main tree species of Białowieża Forest under different habitat conditions. The objective of this chapter is to demonstrate the potential of dendrometer data to determine how stem circumference of selected tree species has changed in different habitats of Białowieża Forest during 2016–2020. To illustrate the diversity of meteorological conditions in Białowieża Forest during the studied period, this chapter presents its characteristics in comparison with long-term averages (1951–2020).

8.2. Materials and Methods

8.2.1. Fieldwork

To monitor changes in stem circumference in Białowieża Forest, automatic measurement with DRL26 tape dendrometers was selected among several existing methods (Mäkinen et al. 2008; Drew and Downes 2009). These are automatic measuring and data recording devices that measure stem circumference and air temperature at a fixed time interval (1 hour). Maintenance is limited to checking the status of the devices every few months when reading the data. Due to the relatively small fieldwork it was possible to use a large number of dendrometers. A total of 278 devices were installed in the Polish part of Białowieża Forest. In 2015, the dendrometers were hung on ten tree species: Scots pine (*Pinus sylvestris* L.) – So, Norway spruce (*Picea abies* (L.) Karst.) – Św, pedunculate oak (*Quercus robur* L.) – Db, Norway maple (*Acer platanoides* L.) – Kl, small-leaved lime (*Tilia cordata* Mill.) – Lp, common ash (*Fraxinus excelsior* L.) – Js, common hornbeam (*Carpinus betulus* L.) – Gb, black alder (*Alnus glutinosa* (L.) Gaertn.) – Ol, elm (*Ulmus* spp.) – Wz, birch (*Betula* spp.) – Brz. The dominant and codominant trees (class I and II, Kraft 1884) were selected for the installation of the equipment. To avoid theft or damage, the dendrometers were attached to

the tree trunks at a height of about 4.5 m above the ground (Fig. 8.1). The devices were hung on 38 study plots established specifically for this purpose, which were located in tree stands over a hundred years old in different habitats and represented the main forest communities of Białowieża Forest. The forest habitat type was determined separately for each tree when the dendrometer was attached. The study plots were located in the Polish part of Białowieża Forest, in areas with different nature conservation regimes: in the Białowieża National Park (including its strictly protected part) (18 study plots, 128 dendrometers), in nature reserves (15 study plots, 110 dendrometers), and in managed forests under the responsibility of the following Forest Districts: Białowieża, Browsk, and Hajnówka (5 study plots, 40 dendrometers) (Fig. 8.2). The average distance of the study plot with dendrometers from the meteorological station of the Institute of Meteorology and Water Management – National Research Institute (IMGW) in Białowieża, from which the meteorological data included in this chapter were obtained (for more details see: „Data Analyses”), is 9 km (the minimum distance is 2.7 km and the maximum distance is 18.6 km). Dendrometer data were downloaded approximately every three months using a non-contact method with infrared communication via a sensor on a boom arm so that the data could be read from the ground. Each data download monitored the condition of the device and the condition of the tree on which the device was installed. If a tree died, broke, fell, or the device was damaged, the dendrometer was replaced or hung on an adjacent tree of the same species with similar dimensions. In some cases, when it was not possible to find a suitable tree within a given study plot, it was necessary to move the dendrometer to another plot representing the same forest type.



Figure 8.1. Attaching a dendrometer to an oak tree in one of the study plots of the ForBioSensing project in the Polish part of Białowieża Forest (photo L. Morel)

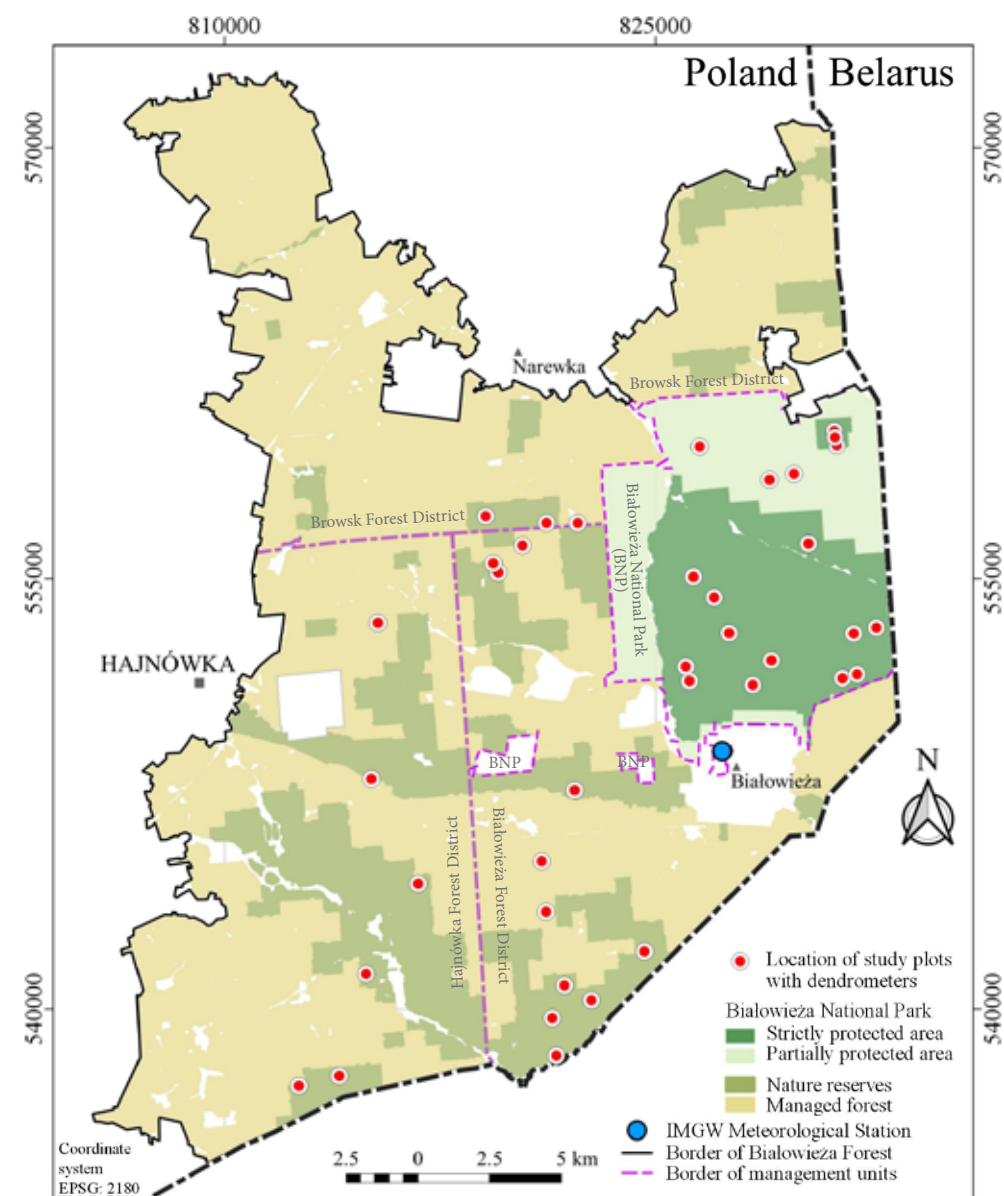

Figure 8.2. Map of the distribution of study plots with dendrometers of the the ForBioSensing project in the Polish part of Białowieża Forest

8.2.2. Data Analyses

Dendrometer data were analysed for habitat groups formed by combining forest habitat types. These groups represent the main forest communities of Białowieża Forest: deciduous forests, mainly oak-lime-hornbeam forests (hereafter: „oak-lime-hornbeam forests”), coniferous forests, alder bog forests, and riparian forests (Tab. 8.1).

Table 8.1. Division of study plots with dendrometers into habitat groups. FDF – fresh deciduous forest, FMDF – fresh mixed deciduous forest, HDF – humid deciduous forest, HMDF – humid mixed deciduous forest, HMCf – humid mixed coniferous forest, FCF – fresh coniferous forest, FMCF – fresh mixed coniferous forest, HCF – humid coniferous forest, ABF – alder bog forest, AASF – alder-ash streamside forest

Habitat group	Forest habitat type	Number of dendrometers
Oak-lime-hornbeam forests	FDF, FMDF, HDF, HMDF, HMCf if there is oak in the 1. stand layer	175
Coniferous forests	FCF, FMCF, HCF, HMCf	54
Alder bog forests and riparian forests	ABF, AASF	49
Total		278

In this chapter, only the results for the trees where the dendrometer continuously recorded changes in stem circumference at least from the beginning of winter 2016 (i.e., from the beginning of winter 2015/2016) to the end of the 2020 growing season are presented. Dead and dying trees were excluded. The resulting collection was divided into species-habitat groups. A species-habitat group is a collection of trees of a particular species growing in forest habitat types that form a particular habitat group (Tab. 8.1). Only groups with at least four trees were analysed. A total of 193 trees were included in the analyses (Tab. 8.2).

Table 8.2. Number of specimens of each tree species in the habitat groups selected for analysis in this chapter. DBH – diameter at breast height (i.e., 1.3 m above the ground)

Species\ Habitat group	Coniferous forests	DBH (cm) mean (min–max)	Oak-lime-hornbeam forests	DBH (cm) mean (min–max)	Alder bog forests and riparian forests	DBH (cm) mean (min–max)	Total
Birch spp.	5	37.0 (25.8–56.4)	15	52.0 (37.2–72.8)			20

Pedunculate oak			28	93.6 (49.8–138.0)			28
Common hornbeam			20	53.2 (39.8–64.5)			20
Common ash			10	66.2 (45.2–99.8)	4	77.4 (62.5–85.0)	14
Norway maple			22	69.5 (52.6–96.5)			22
Small-leaved lime			19	81.4 (46.8–125.5)			19
Black alder			6	64.0 (51.0–83.0)	17	59.5 (37.0–115.0)	23
Scots pine	22	57.0 (37.5–74.2)	8				30
Norway spruce	4	46.9 (42.0–56.5)	6				10
Elm spp.			7	60.0 (41.0–87.5)			7
Total	31		141		21		193

For each of the above species-habitat groups, the mean, median, and variation (for growing season – for individual years, for winter season – for individual winters in 2016–2020) of seasonal stem circumference changes during the growing and winter seasons were calculated, for which separate calculations were performed. In the analyses of stem circumference changes during the 2016–2020 period, the winter season was understood as a period outside the growing season. Calculations were performed for both the meteorological growing season (MGS) and the forest growing season (FGS). Because of the low sensitivity of this measure of variation to outliers, variation was calculated as the difference between the first and third quartile. In this chapter, changes in stem circumference during the growing season are considered stem circumference growth (see „Introduction”).

The meteorological data used for the analyses come from a meteorological station in the centre of Białowieża Glade (pl. *Polana Białowieska*), in the village of Białowieża. The owner of the data is the Institute of Meteorology and Water Management – National Research Institute (IMGW, www.dane.imgw.pl). The IMGW data were processed for the preparation of this chapter.

The beginning and end points of the meteorological growing season (MGS) and forest growing season (FGS) were determined according to the method of Huculak and Makowiec (1977) (after Bartoszek et al. 2012). The beginning of the growing season was defined as the first day with a daily mean temperature equal to or above the threshold temperature (5°C for MGS and 10°C for FGS), from which the cumulative series of daily mean temperature deviations from the threshold temperature reached positive values until the end of the first half of the year. The end of the growing season was defined as the first day with a temperature less than or equal to the threshold temperature, from which the cumulative series of daily mean temperature deviations from the threshold temperature reached negative values until the end of the year.

To compare the 2016–2020 period with the long-term average of the 1951–2020 period, a classification of thermal and precipitation conditions was made. Lorenc’s (2000) classification was used to compare thermal conditions. Thermal classes were formed based on annual average temperatures and standard deviation. Between 0.5 and 2.5 standard deviations were added to and subtracted from the mean in 0.5 standard deviation increments to form thermal classes. The annual mean temperature was then assigned to the appropriate class. Precipitation was classified according to the method of Kaczorowska (1962). Precipitation classes were formed based on the percentage deviation from the long-term average in 25% increments, to which the annual precipitation totals from 2016–2020 were assigned.

The Selianinov hydrothermal coefficient was also used. It was calculated for each growing season (and for the long-term average) according to the following formula (Jendrzyszczak 2005):

$$k = (\sum P) / (0,1 * \sum T_{(sr\ d)})$$

Where:

k – Selianinov coefficient;

$\sum P$ – sum of precipitation during the growing season;

$\sum T_{(sr\ d)}$ – sum of daily mean temperatures during the growing season.

Winter conditions in a given year were described using the Paczos index (1985) to calculate winter severity (Olszewski et al. 1992). The winter period was defined as the time from the beginning of December of the previous year (01.12.) to the end of March of the current year (31.03.). The index was calculated for winters in the period 2016–2020, and a long-term average was also calculated for the period 1951–2020. In addition to winter severity, the number of winter days (mean daily temperature < 0°C), cold days (maximum daily temperature < 0°C), extremely cold days (minimum daily temperature < -10°C), mean winter

temperature, mean minimum winter temperature, and total winter precipitation were also listed. The winter severity index was calculated using the following formula::

$$Wp = (1 - 0,25T)0,8325 + 0,0144dz + 0,0087dm + 0,0045dbm - 0,0026ST$$

Where:

Wp – winter severity index;

T – mean winter temperature in °C, calculated on the basis of monthly mean temperatures;

dz – number of winter days;

dm – number of cold days;

dbm – number of extremely cold days;

ST – sum of daily temperatures below 0°C.

8.3. Results

8.3.1. Changes in Tree Stem Volume in Białowieża Forest during the 2016–2020 period

8.3.1.1. Changes in Tree Stem Circumference in 2016–2020

In 2016–2020, the highest stem circumference growth, i.e., change in stem circumference during the growing season (see „Data Analyses”), was recorded for tree species in oak-lime-hornbeam forests, namely elm (Fig. 8.3–8.4), spruce (Fig. 8.3 and 8.5), alder (Fig. 8.3 and 8.12), and pedunculate oak (Fig. 8.3 and 8.7). The lowest values of stem circumference growth were found for lime in oak-lime-hornbeam forests (Figs. 8.3 and 8.10) and for birch in coniferous forests and oak-lime-hornbeam forests (Fig. 8.6). For some species, such as spruce, there was a clear dependence of stem circumference growth on habitat conditions (Fig. 8.5). Significant stem shrinkage was observed during winter periods, which is particularly striking when comparing the periods of the most severe winter in 2017/2018 and the mildest winter in 2019/2020 (Fig. 8.3–8.13).

8.3.1.2. Changes in Tree Stem Circumference during Growing Season in 2016–2020

In the analysed period 2016–2020, the highest values of stem circumference changes during the growing season (i.e., stem circumference growth, see „Data Analyses”) were recorded in oak-lime-hornbeam forests. Elm in oak-lime-hornbeam forests was characterised by the highest median of stem circumference growth during 2016–2020. This species achieved the highest stem circumference growth (over 16 mm year⁻¹), particularly in 2016 and 2017.

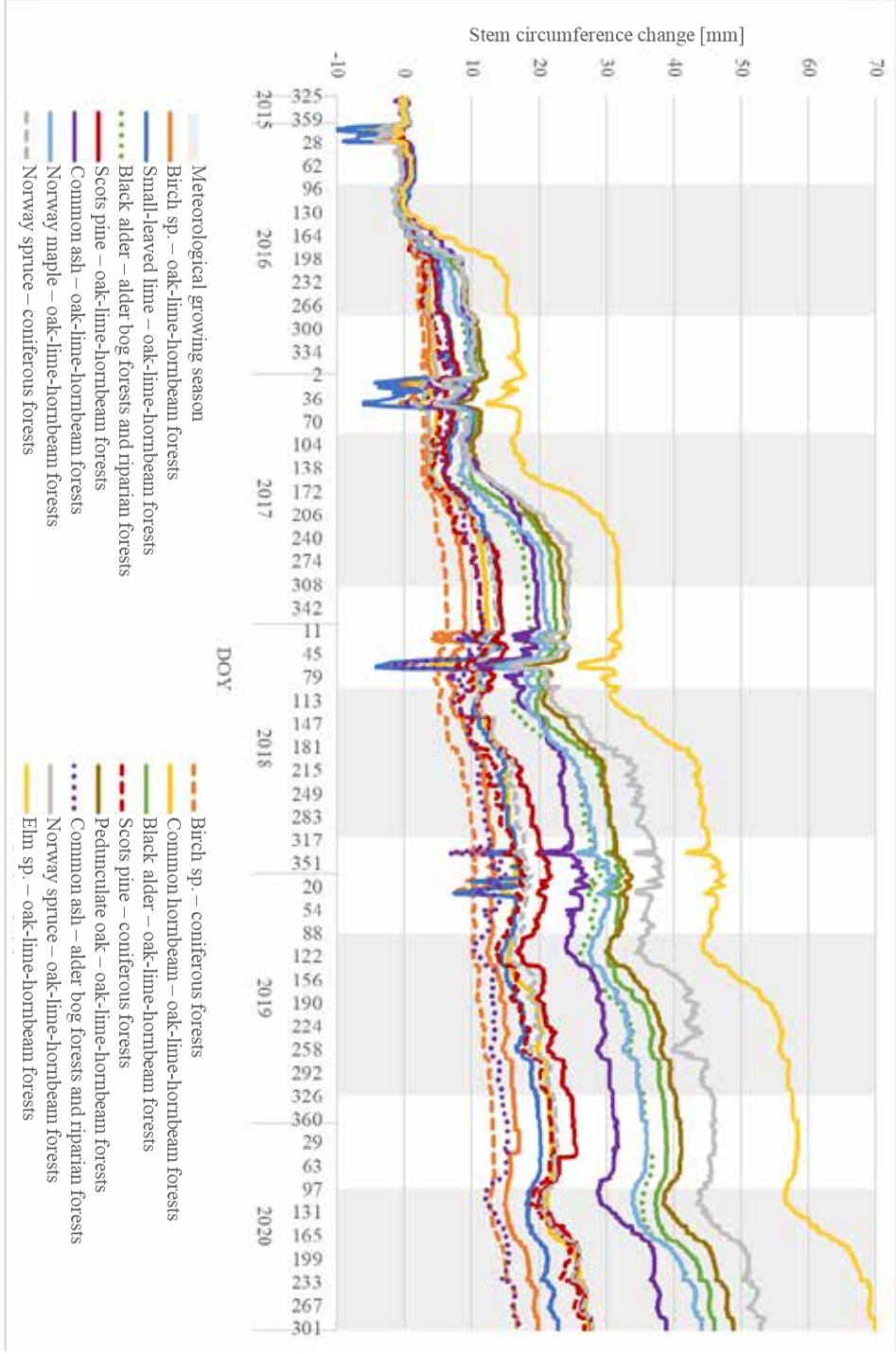

Figure 8.3. Changes in stem circumference of selected tree species in Białowieża Forest in different habitats in 2016–2020 (from the beginning of the 2015/2016 winter season to the end of the 2020 growing season). DOY – day of year

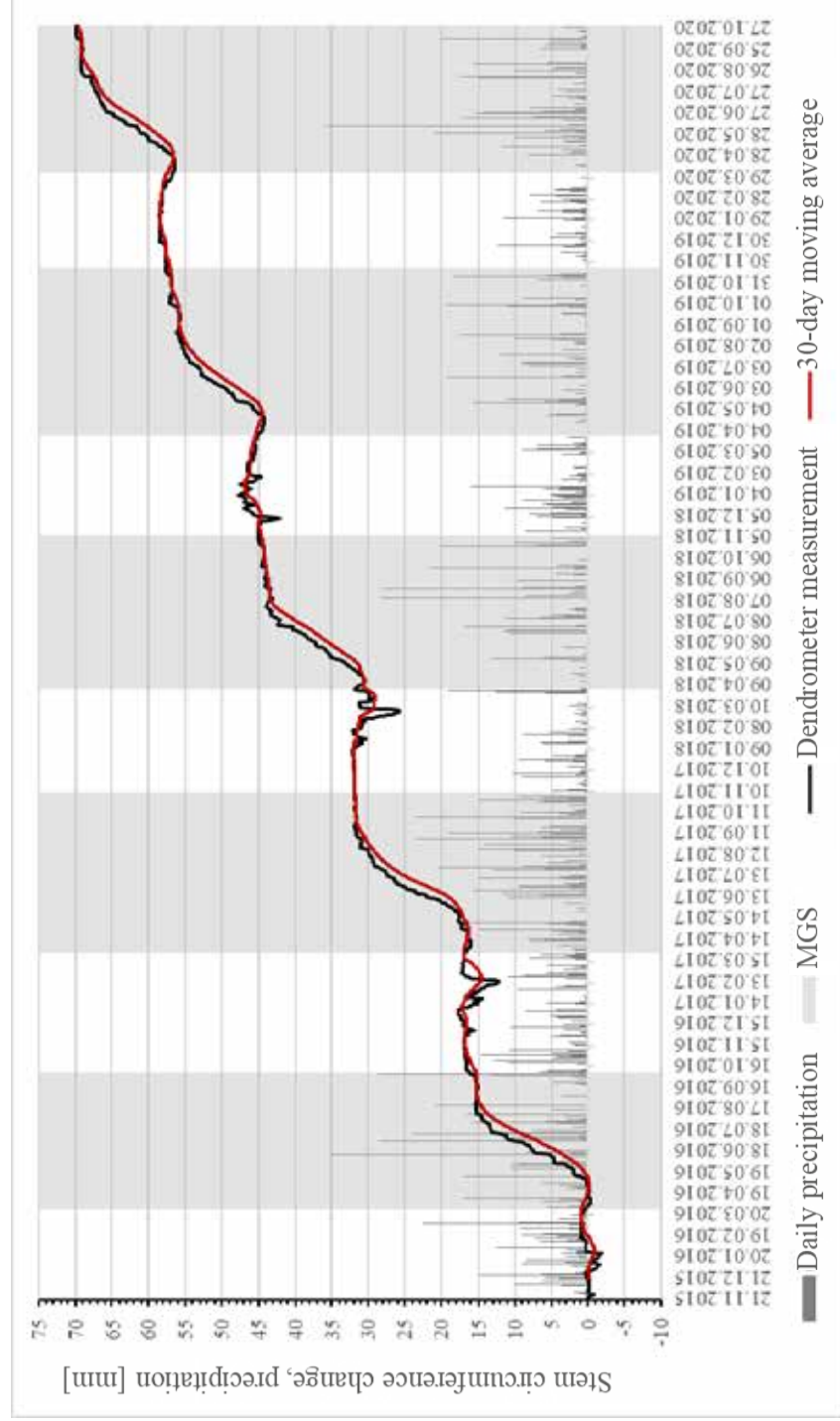

Figure 8.4. Changes in stem circumference of elm in oak-lime-hornbeam forests of Białowieża Forest in 2016–2020 (from the beginning of the 2015/2016 winter season to the end of the 2020 growing season) ($n=7$). Black curve – arithmetic mean for the sampled trees, red curve – moving average (window: 30 days) of the mean for the measurements of all sampled trees. MGS – meteorological growing season

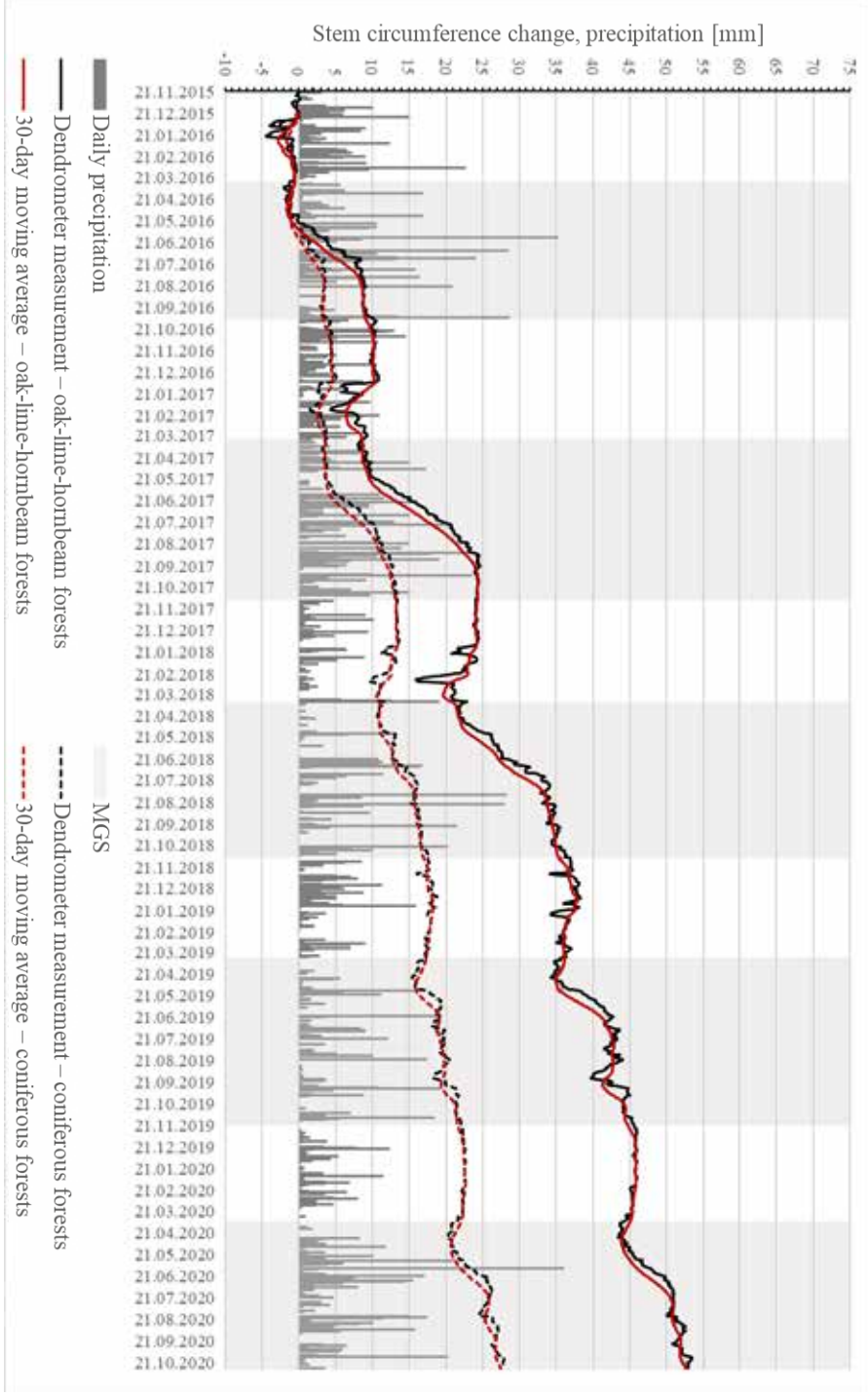

Figure 8.5. Changes in stem circumference of spruce in oak-lime-hornbeam forests (n=6) and coniferous forests (n=4) of Białowieża Forest in 2016–2020 (from the beginning of the 2015/2016 winter season to the end of the 2020 growing season). Black curve – arithmetic mean for the sampled trees, red curve – moving average (window: 30 days) of the mean for the measurements of all sampled trees. Solid line – oak-lime-hornbeam forests, dashed line – coniferous forests. MGS – meteorological growing season

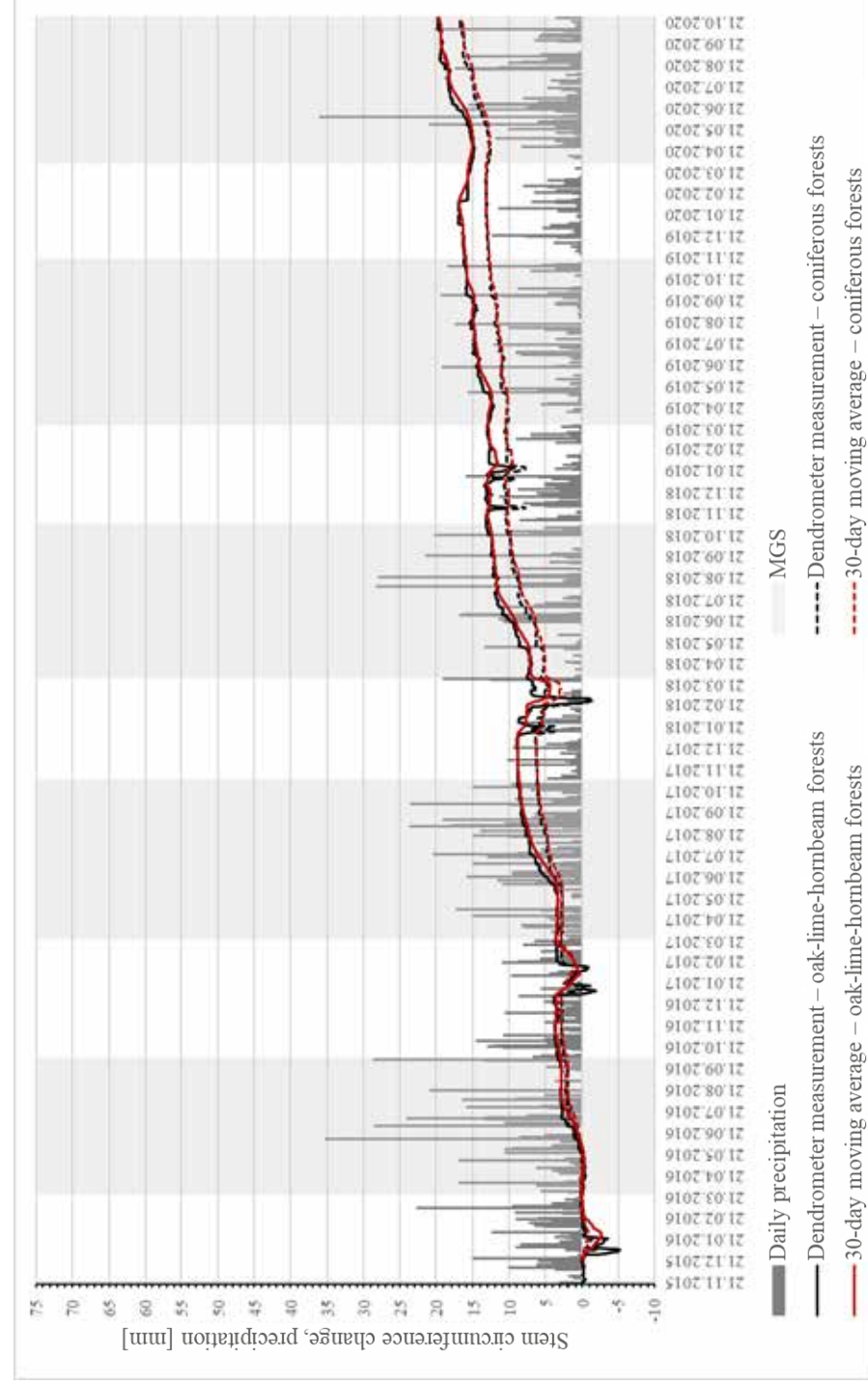

Figure 8.6. Changes in stem circumference of birch in oak-lime-hornbeam forests (n=15) and coniferous forests (n=5) of Białowieża Forest in 2016–2020 (from the beginning of the 2015/2016 winter season to the end of the 2020 growing season). Black curve – arithmetic mean for the sampled trees, red curve – moving average (window: 30 days) of the mean for the measurements of all sampled trees. Solid line – oak-lime-hornbeam forests, dashed line – coniferous forests. MGS – meteorological growing season

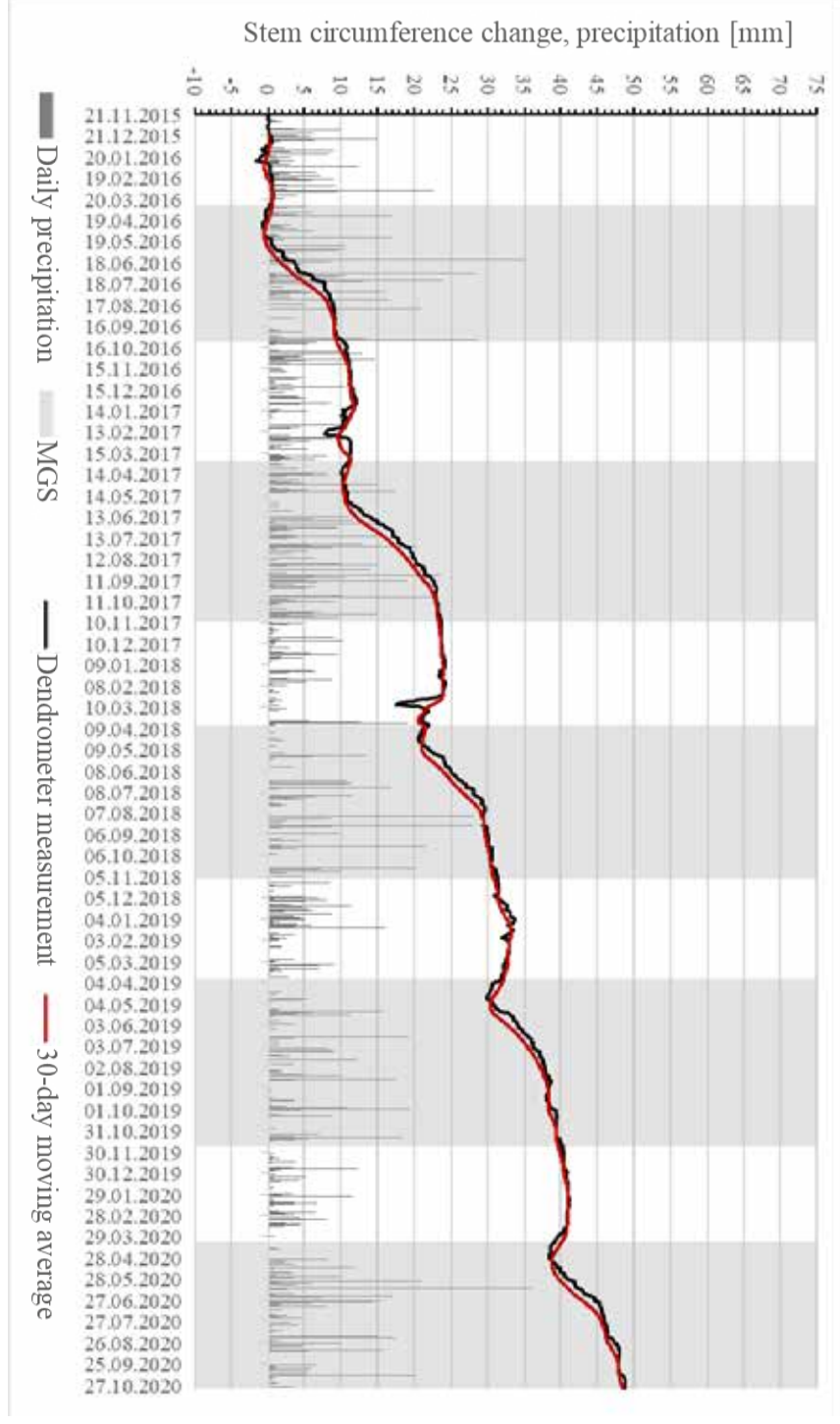

Figure 8.7. Changes in stem circumference of oak in oak-lime-hornbeam forests of Białowieża Forest in 2016–2020 (from the beginning of the 2015/2016 winter season to the end of the 2020 growing season) (n=28). Black curve – arithmetic mean for the sampled trees, red curve – moving average (window: 30 days) of the mean for the measurements of all sampled trees. MGS – meteorological growing season

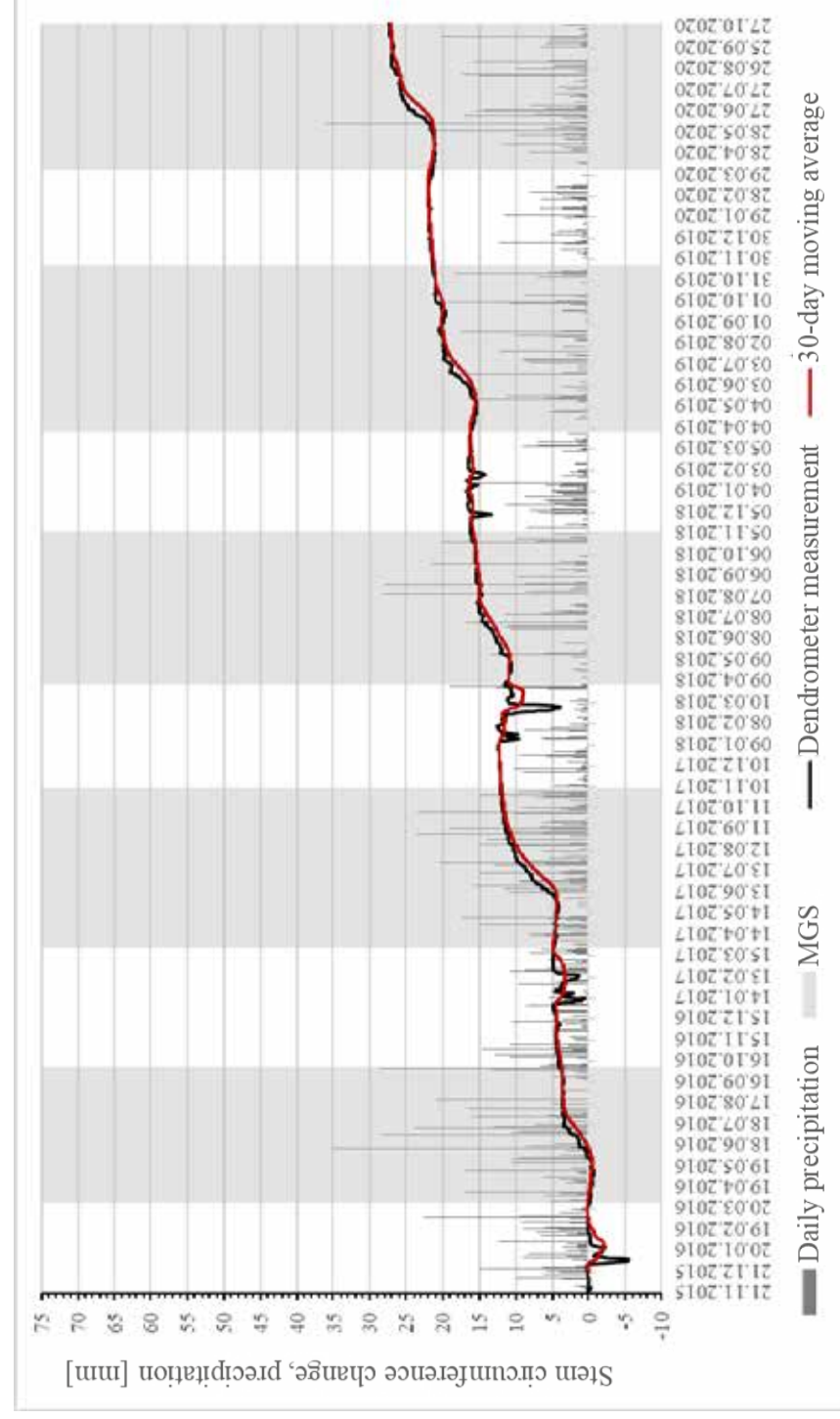

Figure 8.8. Changes in stem circumference of hornbeam in oak-lime-hornbeam forests of Białowieża Forest in 2016–2020 (from the beginning of the 2015/2016 winter season to the end of the 2020 growing season) (n=20). Black curve – arithmetic mean for the sampled trees, red curve – moving average (window: 30 days) of the mean for the measurements of all sampled trees. MGS – meteorological growing season

Figure 8.9. Changes in stem circumference of maple in oak-lime-hornbeam forests of Białowieża Forest in 2016–2020 (from the beginning of the 2015/2016 winter season to the end of the 2020 growing season) (n=22). Black curve – arithmetic mean for the sampled trees, red curve – moving average (window: 30 days) of the mean for the measurements of all sampled trees. MGS – meteorological growing season

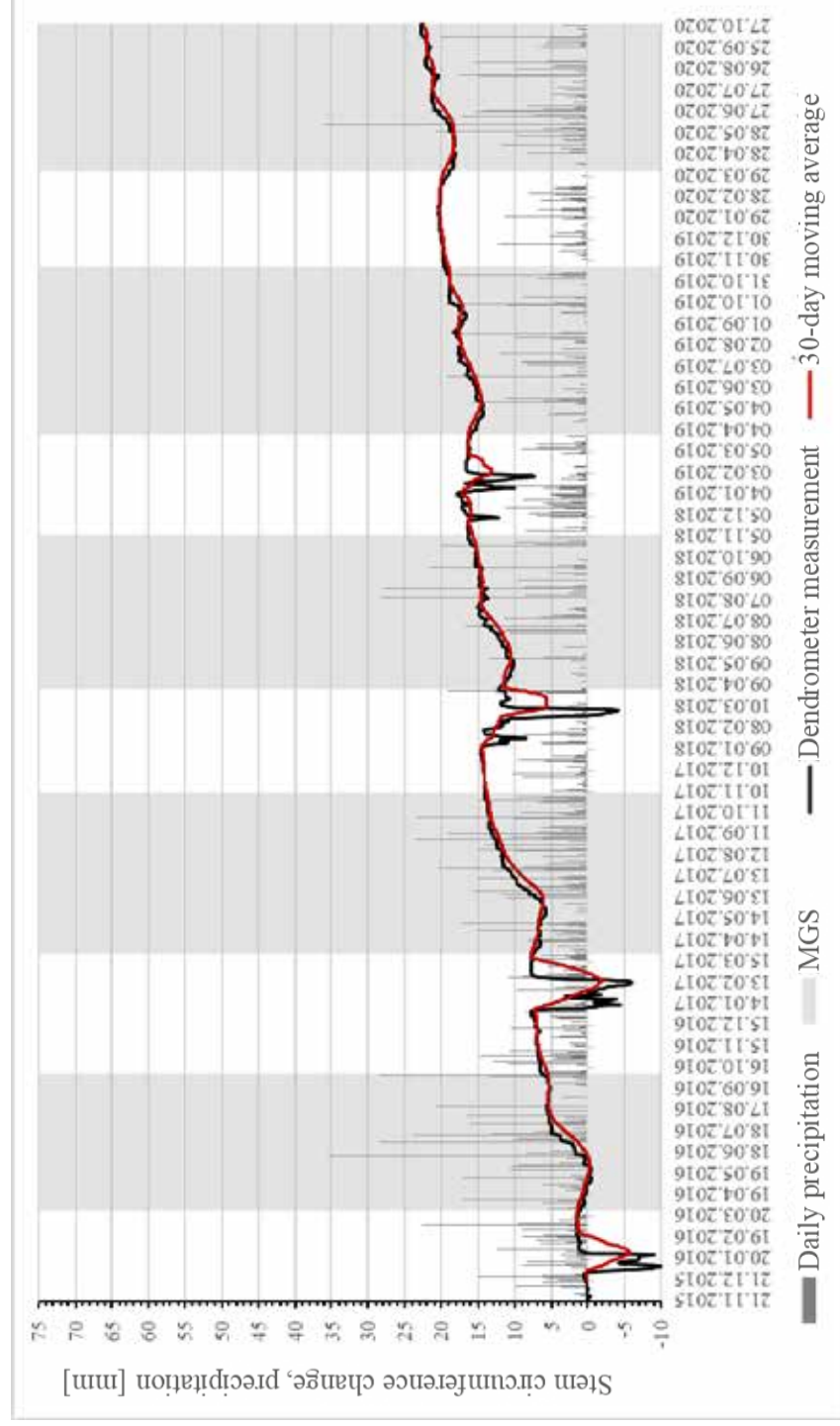
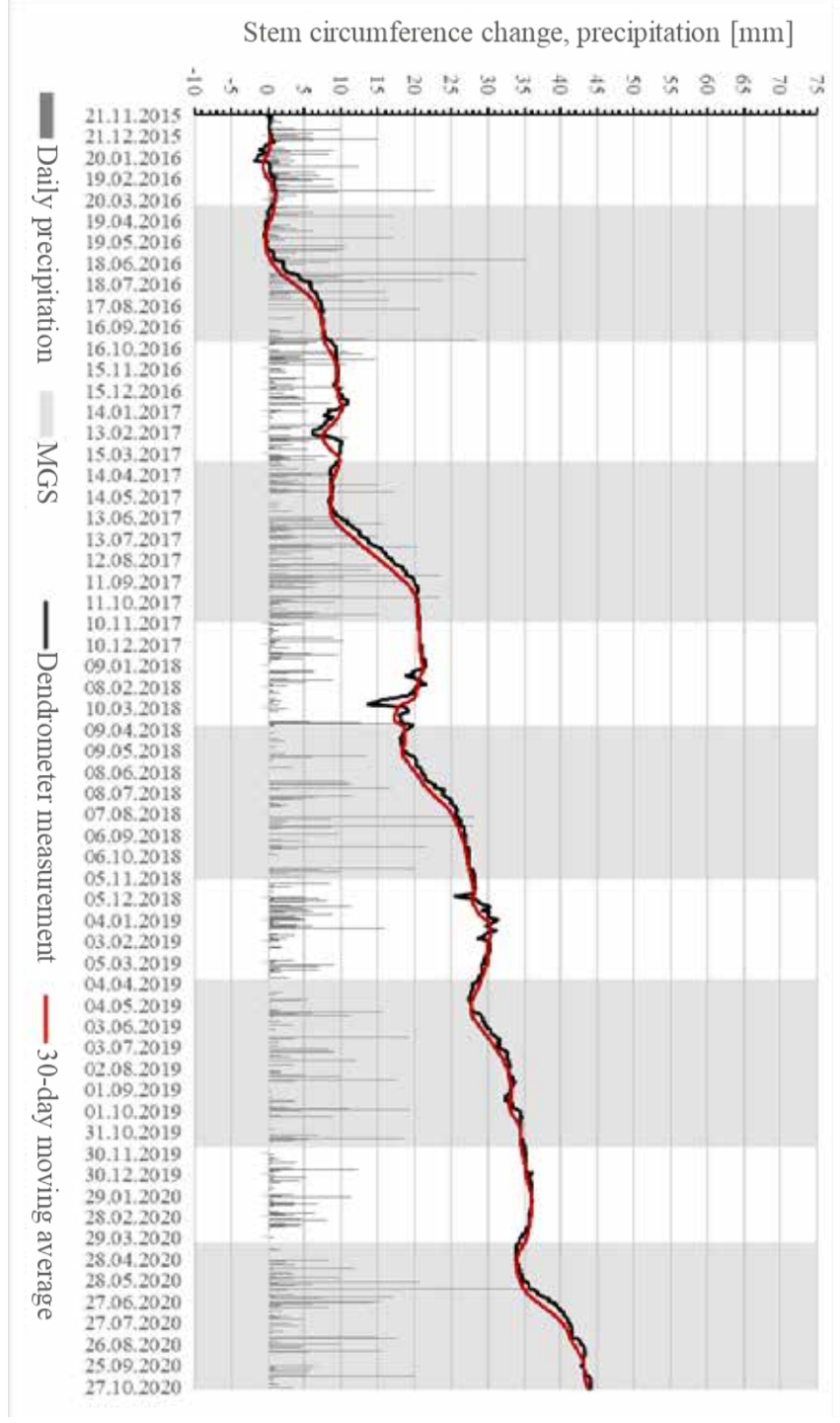

Figure 8.10. Changes in stem circumference of lime in oak-lime-hornbeam forests of Białowieża Forest in 2016–2020 (from the beginning of the 2015/2016 winter season to the end of the 2020 growing season) (n=19). Black curve – arithmetic mean for the sampled trees, red curve – moving average (window: 30 days) of the mean for the measurements of all sampled trees. MGS – meteorological growing season

Figure 8.11. Changes in stem circumference of ash in oak-lime-hornbeam forests (n=10) and alder bog forests and riparian forests (n=4) of Białowieża Forest in 2016–2020 (from the beginning of the 2015/2016 winter season to the end of the 2020 growing season). Black curve – arithmetic mean for the sampled trees, red curve – moving average (window: 30 days) of the mean for the measurements of the sampled trees. Solid line – oak-lime-hornbeam forests, dotted line – alder bog forests and riparian forests. MGS – meteorological growing season

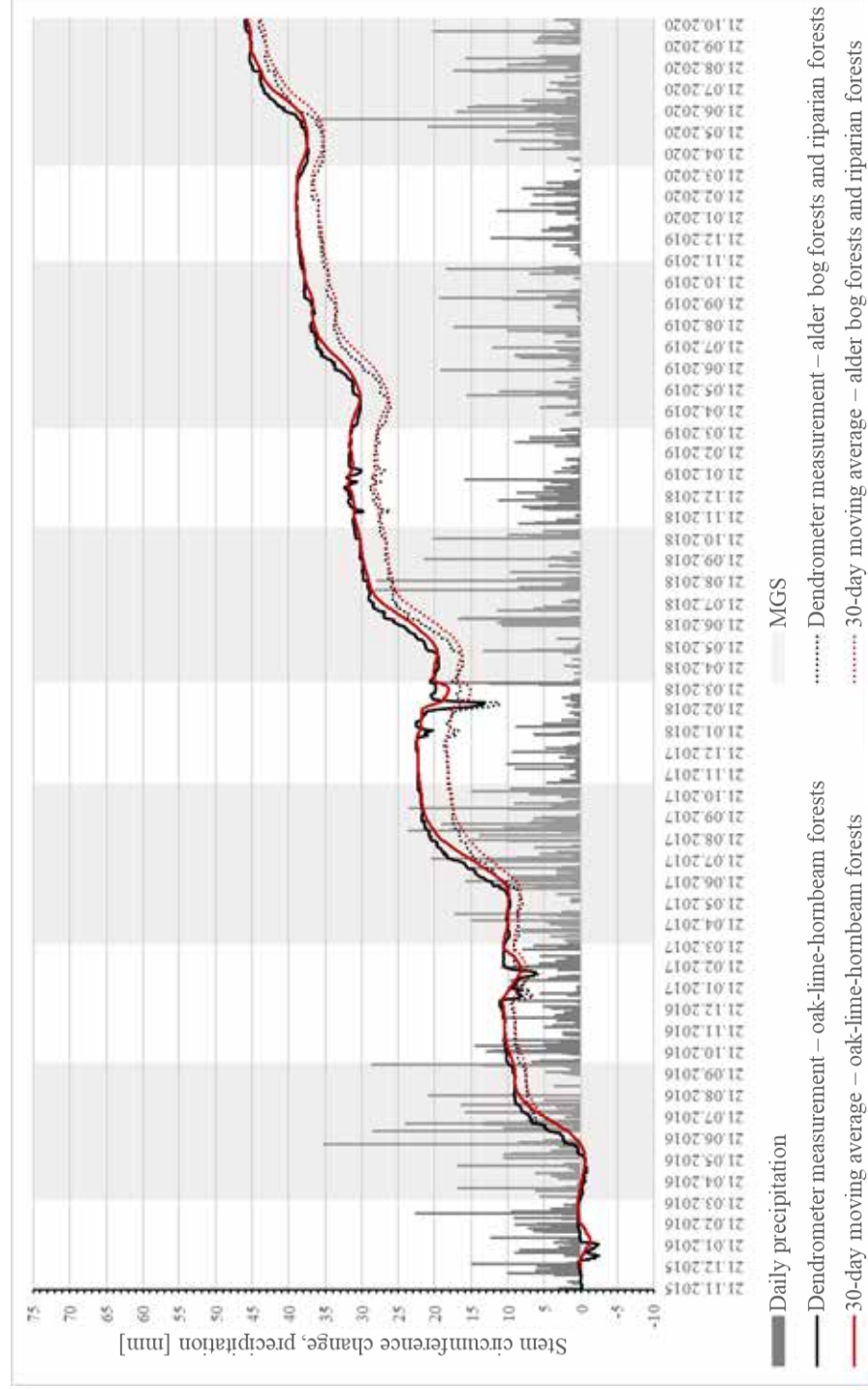
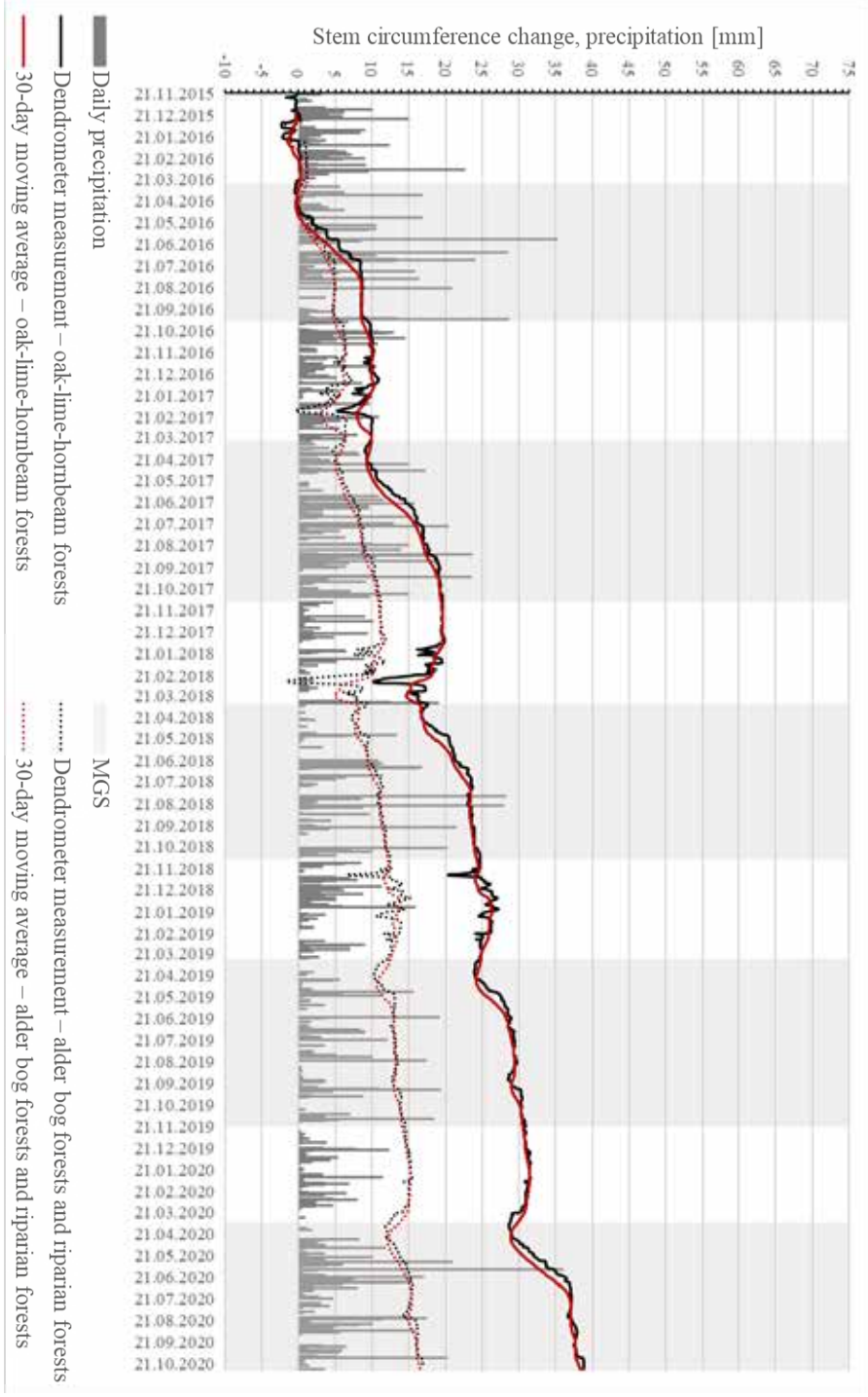

Figure 8.12. Changes in stem circumference of alder in oak-lime-hornbeam forests (n=6) and alder bog forests and riparian forests (n=17) of Białowieża Forest in 2016–2020 (from the beginning of the 2015/2016 winter season to the end of the 2020 growing season). Black curve – arithmetic mean for the sampled trees, red curve – moving average (window: 30 days) of the mean for the measurements of all sampled trees. Solid line – oak-lime-hornbeam forests, dotted line – alder bog forests and riparian forests. MGS – meteorological growing season

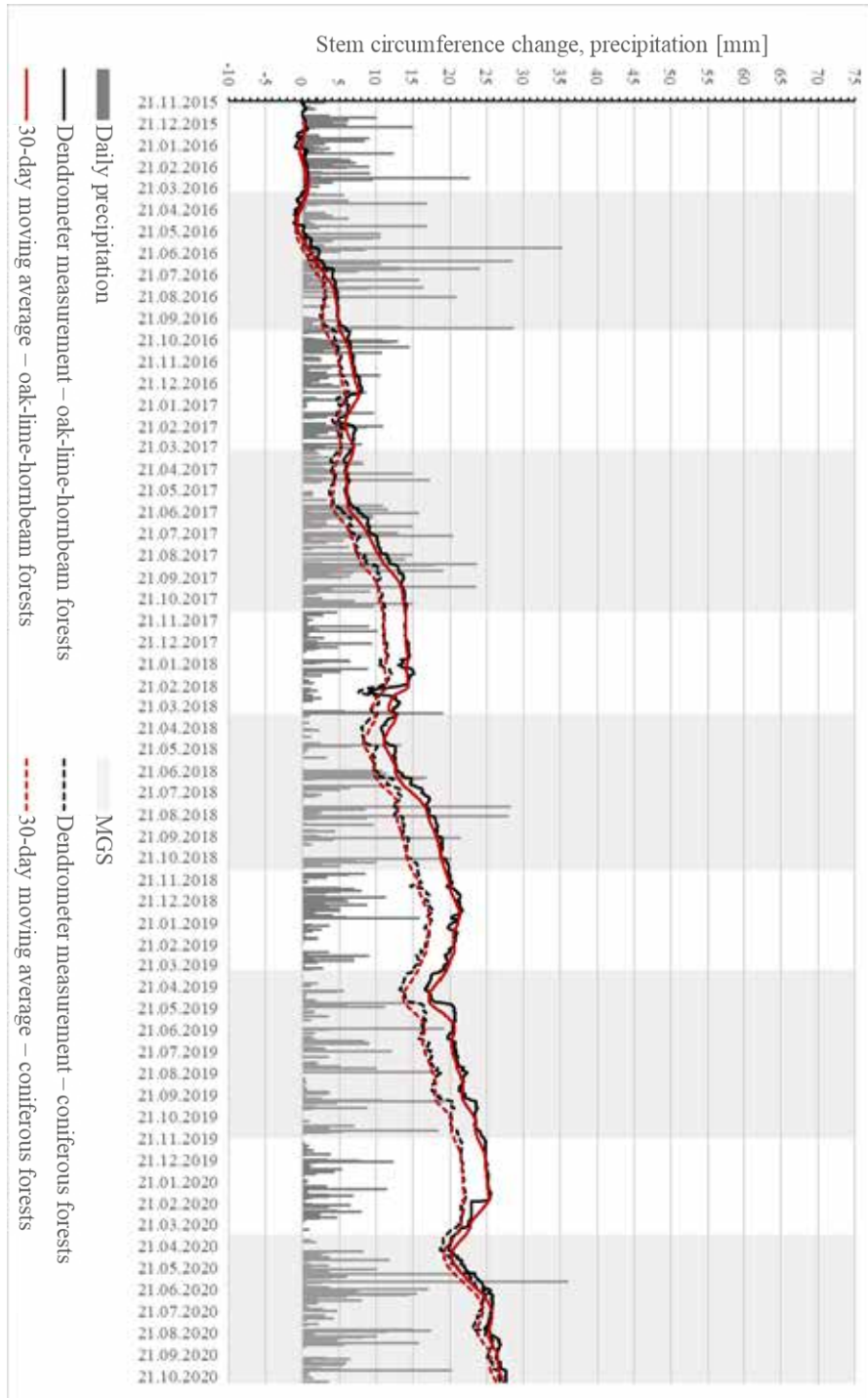

Figure 8.13. Changes in stem circumference of pine in oak-lime-hornbeam forests (n=8) and coniferous forests (n=22) of Białowieża Forest in 2016–2020 (from the beginning of the 2015/2016 winter season to the end of the 2020 growing season). Black curve – arithmetic mean for the sampled trees, red curve – moving average (window: 30 days) of the mean for the measurements of all sampled trees. Solid line – oak-lime-hornbeam forests, dashed line – coniferous forests. MGS – meteorological growing season

The second species with the highest stem circumference growth was spruce in oak-lime-hornbeam forests, which also achieved the highest values (over 13 mm year⁻¹) in 2017. The third species was oak in oak-lime-hornbeam forests, which also reached the highest values in stem circumference growth in 2017. Alder and maple in oak-lime-hornbeam forests should also be mentioned, which reached the highest values in stem circumference growth (over 11 mm) in 2017. On the other hand, the species with the lowest values for stem circumference growth in the studied period included: lime in oak-lime-hornbeam forests and birch in coniferous forests and oak-lime-hornbeam forests (Tab. 8.3, Fig. 8.14). An interesting feature observed for both the meteorological growing season and the forest growing season is that most species had the highest stem circumference growth in 2017, which then decreased and reached a minimum in 2019, while in 2020 it had values approaching those of 2018 (Fig. 8.3 and 8.14). Spruce and birch in oak-lime-hornbeam forests and ash in alder bog forests and riparian forests continued their downward trend in 2020. In contrast, alder in alder bog forests and riparian forests reached its maximum stem circumference growth in 2018. Hornbeam in oak-lime-hornbeam forests was an exception compared to the other tree species, reaching its maximum stem circumference growth in 2020 (Tab. 8.3, Fig. 8.14). The highest variation in stem circumference growth during 2016–2020 was observed for lime (8.87 mm) and pine (6.83 mm) in oak-lime-hornbeam forests. The lowest variation was found for birch in coniferous forests (1.0 mm) and alder in oak-lime-hornbeam forests (2.11 mm) (Tab. 8.4).

Table 8.3. Medians of stem circumference growth (mm) of selected tree species in habitat groups during the growing season (meteorological growing season – MGS and forest growing season – FGS) in the period 2016–2020 in Białowieża Forest

Species	Habitat group	2016		2017		2018		2019		2020	
		MGS	FGS	MOW	FGS	MOW	FGS	MOW	FGS	MOW	FGS
Birch spp.	coniferous forests	1.28	1.39	3.2	2.96	2.12	1.47	1.86	1.37	1.34	1.4
Birch spp.	oak-lime-hornbeam forests	2.89	2.73	4.95	4.63	4.4	2.84	2.49	2.05	3.38	3.63
Pedunculate oak	oak-lime-hornbeam forests	10.62	10.54	12.31	12.02	9.83	8.57	7.36	7.16	9.99	9.71
Common hornbeam	oak-lime-hornbeam forests	3.77	3.83	5.68	5.51	4.22	3.56	5.37	4.12	6.66	6.59
Common ash	oak-lime-hornbeam forests	7.08	6.95	8.4	7.94	6.06	4.9	5.55	3.58	9.47	7.92
Common ash	alder bog forests and riparian forests	4.66	4.57	4.86	4.84	3.29	2.25	1.92	2.24	4.43	3.97
Norway maple	oak-lime-hornbeam forests	8.68	8.73	11.35	11.88	8.27	7.21	6.08	5.17	9.36	8.9

Small-leaved lime	oak-lime-hornbeam forests	1.9	2.52	2.6	2.58	0.44	-1.14	0.31	-1.39	2.35	2.49
Black alder	oak-lime-hornbeam forests	8.81	9.21	11.73	11.55	10.5	9.36	6.46	5.82	8.77	8.46
Black alder	alder bog forests and riparian forests	7.27	7.65	8.17	7.99	8.83	7.44	6.55	5.94	8.25	8.25
Scots pine	coniferous forests	3.62	4.22	5.95	5.92	5.36	3.08	5.2	3.86	5.96	5.84
Scots pine	oak-lime-hornbeam forests	6.66	7.41	8.14	8.49	8.13	6.77	4.73	3.78	8.28	7.67
Norway spruce	coniferous forests	2.88	3.09	8.85	8.09	6.1	4.41	4.39	1.78	5.48	5.74
Norway spruce	oak-lime-hornbeam forests	11.83	11.25	13.01	12.68	12.62	11.56	9.84	4.84	8.69	8.48
Elm spp.	oak-lime-hornbeam forests	16.6	16.39	16.21	15.54	14.41	13.69	10.93	10.19	12.2	11.77

Table 8.4. Variation (i.e., difference between the first and third quartile) of stem circumference growth of selected tree species in habitat groups during the meteorological growing season (MGS) (mm) in 2016–2020 in Białowieża Forest

Species	Habitat group	2016	2017	2018	2019	2020	Average
Birch spp.	coniferous forests	0.74	1.08	0.99	1.57	0.6	1.00
Birch spp.	oak-lime-hornbeam forests	1.88	4.14	4.51	2.58	4.05	3.43
Pedunculate oak	oak-lime-hornbeam forests	4.83	6.35	3.39	4.39	3.38	4.47
Common hornbeam	oak-lime-hornbeam forests	4.02	7.48	5.05	4.14	4.62	5.06
Common ash	oak-lime-hornbeam forests	5.72	5.43	2.8	2.33	4.06	4.07
Common ash	alder bog forests and riparian forests	0.26	0.5	0.68	1.19	3.71	1.27
Norway maple	oak-lime-hornbeam forests	5.17	5.76	5.82	2.92	5.8	5.09
Small-leaved lime	oak-lime-hornbeam forests	10.65	10.75	7.44	8.66	6.84	8.87
Black alder	oak-lime-hornbeam forests	2.92	1.37	3.92	1.18	1.18	2.11
Black alder	alder bog forests and riparian forests	3.51	5.2	5.25	5.95	2.99	4.58
Scots pine	coniferous forests	2.76	3.88	4.8	4.53	4.32	4.06
Scots pine	oak-lime-hornbeam forests	6.17	7.09	8.38	6.06	6.44	6.83
Norway spruce	coniferous forests	2.4	7.33	2.35	1.38	2.9	3.27
Norway spruce	oak-lime-hornbeam forests	4.87	3.28	3.02	3.96	2.32	3.49
Elm spp.	oak-lime-hornbeam forests	2.14	5.95	7.6	6.81	11.76	6.85

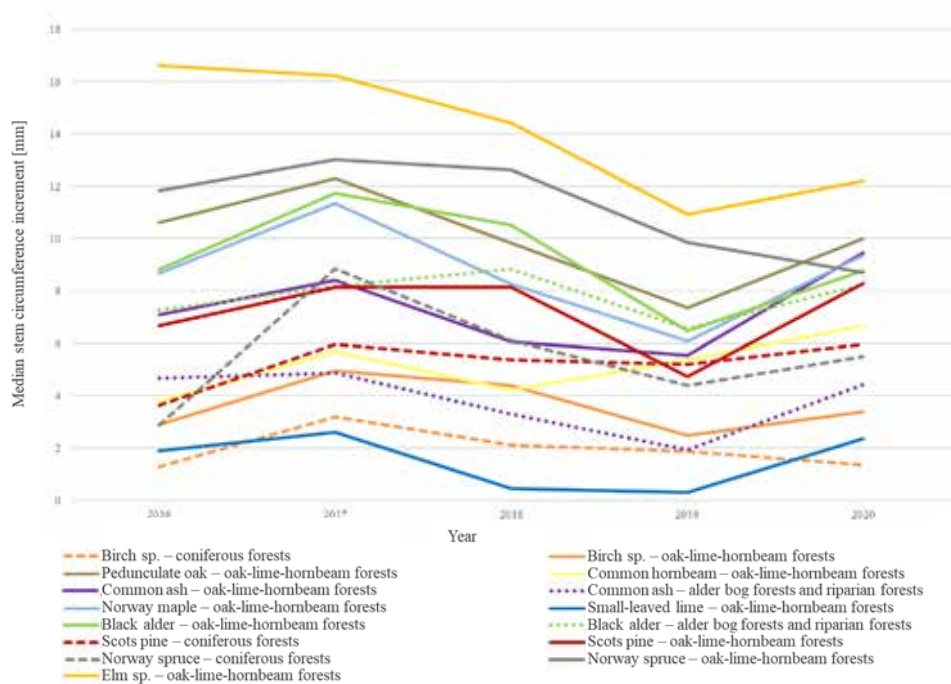

Figure 8.14. Median of stem circumference growth of selected tree species during the meteorological growing season (MGS) in Białowieża Forest in 2016–2020

Depending on the year, the median and variation of stem circumference growth showed different values for the same tree species. This was most evident for lime, where variation was higher in the first two years; for hornbeam in oak-lime-hornbeam forests, where variation was 3.5 and 2.5 mm higher in 2017 than in the previous year and the following year, respectively; for elm, where variation was clearly lowest in 2016 compared to the other years; for spruce in coniferous forests, where variation was highest in 2017; for ash, where variation was lower by about 3 mm in the last two years; for oak, which had the highest variation in 2017. The mean variation was highest for all tree species in 2017 (Fig. 8.15).

8.3.1.3. Changes in Tree Stem Circumference during Winter Season in 2016–2020

The highest changes in tree stem circumference during the winter season were recorded in winter of 2017/2018. This was the most severe of the winters in the studied period 2016–2020. Definitely the strongest stem shrinkage was observed then. However, stem shrinkage was also found during the mildest winter of 2019/2020. Ash and spruce stems shrank the most during the winter seasons (Tab. 8.5). The variation in tree stem circumference changes during the winter season was greatest during the coldest winter of 2017/2018. The highest variation in the studied period was observed for lime, while the lowest variation was observed for birch in coniferous forests (Tab. 8.6).

Table 8.5. Medians of stem circumference changes (mm) of selected tree species in habitat groups during winter season in 2016–2020 in Białowieża Forest

Species	Habitat group	2015/16	2016/17	2017/18	2018/19	2019/20
Birch spp.	coniferous forests	0.25	0.55	-0.51	0.24	0.16
Birch spp.	oak-lime-hornbeam forests	0.09	0.26	-0.91	-0.08	-0.2
Pedunculate oak	oak-lime-hornbeam forests	0.27	1	-1.51	0.32	-0.91
Common hornbeam	oak-lime-hornbeam forests	0.01	0.53	-0.51	0.05	-0.17
Common ash	oak-lime-hornbeam forests	-0.27	0.26	-2.19	-0.05	-1.96
Common ash	alder bog forests and riparian forests	0.03	0.87	-1.74	-0.29	-1.97
Norway maple	oak-lime-hornbeam forests	0.57	0.99	-0.8	0.56	-0.69
Small-leaved lime	oak-lime-hornbeam forests	0.37	0.56	-1.9	-0.39	-0.43
Black alder	oak-lime-hornbeam forests	0.25	0.57	-1.12	0.41	-0.43
Black alder	alder bog forests and riparian forests	0.21	1.01	-0.71	0.01	-0.68
Scots pine	coniferous forests	0.28	1.26	-0.89	-0.47	-1.39
Scots pine	oak-lime-hornbeam forests	0.39	0.74	-1.19	-0.52	-1.6
Norway spruce	coniferous forests	-0.91	0.09	-1.4	-0.27	-0.37
Norway spruce	oak-lime-hornbeam forests	-1.14	-0.95	-1.51	-0.41	-1.08
Elm spp.	oak-lime-hornbeam forests	0.39	0.56	-0.26	0.1	-1

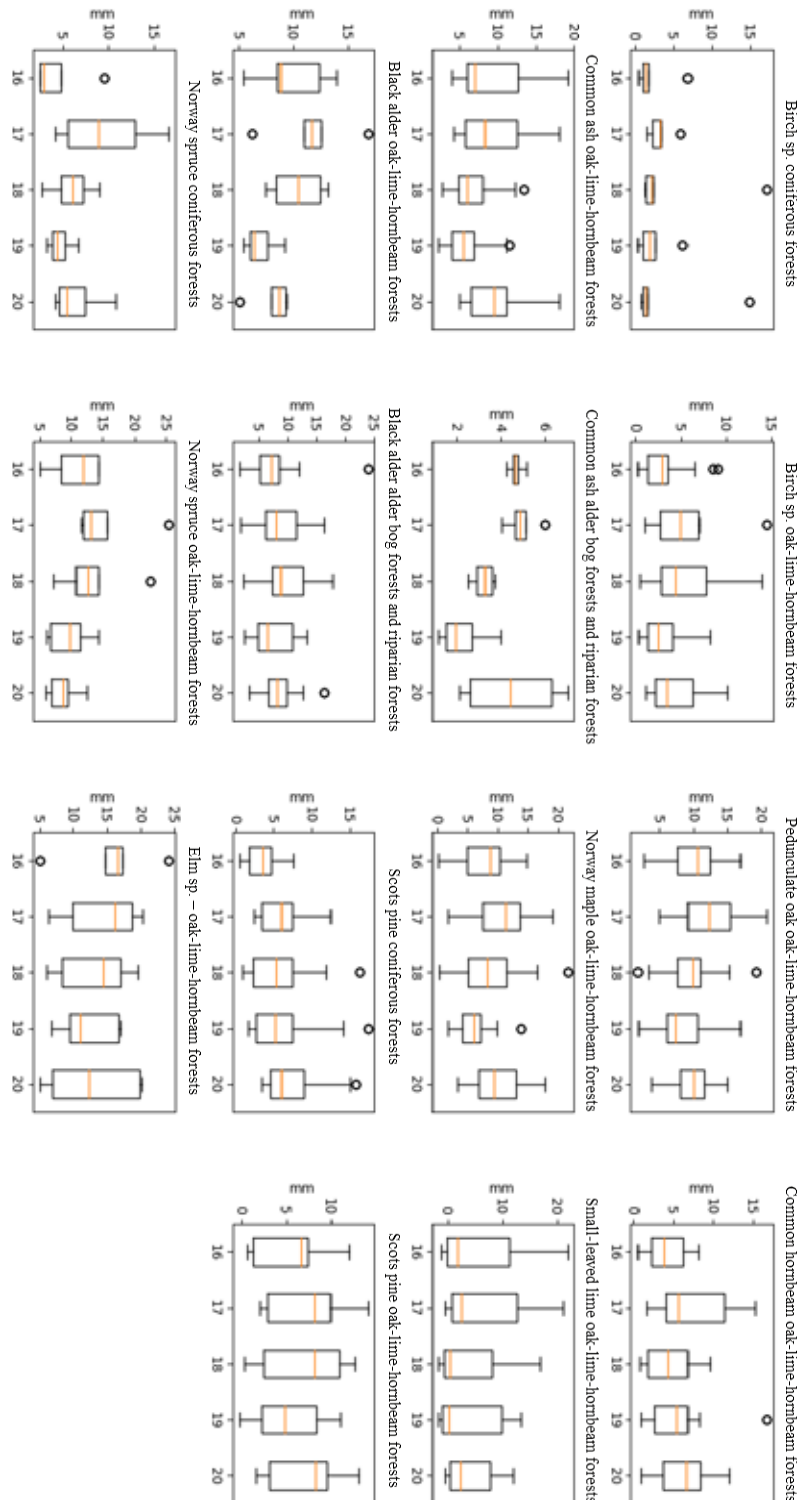

Figure 8.15. Variation of stem circumference growth of selected tree species in habitat groups during the meteorological growing season in 2016–2020 in Białowieża Forest. The orange line denotes the median, the box indicates the position of the 1st and 3rd quartiles, the whiskers indicate the limit values of the sample (last value below $Q3+1.5*(Q3-Q1)$ or last value above $Q1-1.5*(Q3-Q1)$), the ovals are the outliers, i.e., the values outside the indicated sample limits, the numbers 16–20 on the horizontal axis denote the respective years during the 2016–2020 period

Table 8.6. Variation of stem circumference changes (mm) of selected tree species in habitat groups during winter season in 2016–2020 in Białowieża Forest

Species	Habitat group	2015/16	2016/17	2017/18	2018/19	2019/20	Average
Birch spp.	coniferous forests	0.13	0.4	0.46	0.29	0.1	0.28
Birch spp.	oak-lime-hornbeam forests	0.34	0.75	1	0.35	0.39	0.57
Pedunculate oak	oak-lime-hornbeam forests	0.46	0.82	1.19	0.8	0.	0.75
Common hornbeam	oak-lime-hornbeam forests	0.32	1.17	0.59	0.43	0.34	0.57
Common ash	oak-lime-hornbeam forests	0.74	0.65	1.73	0.33	0.65	0.82
Common ash	alder bog forests and riparian forests	0.82	1.33	1.56	0.15	0.89	0.95
Norway maple	oak-lime-hornbeam forests	0.61	0.5	1.22	0.99	0.72	0,81
Small-leaved lime	oak-lime-hornbeam forests	4.14	3.06	5.72	3.1	0.45	3.29
Black alder	oak-lime-hornbeam forests	0.28	0.19	1.82	0.29	0.24	0.56
Black alder	alder bog forests and riparian forests	0.35	0.3	0.54	0.25	0.43	0.37
Scots pine	coniferous forests	0.56	0.58	0.69	0.75	0.94	0.70
Scots pine	oak-lime-hornbeam forests	1.02	0.98	0.49	1.27	1.46	1.04
Norway spruce	coniferous forests	0.26	0.63	1.18	0.49	0.28	0.57
Norway spruce	oak-lime-hornbeam forests	0.92	0.42	0.66	0.8	0.13	0.59
Elm spp.	oak-lime-hornbeam forests	0.2	0.54	1.24	0.57	0.55	0.62

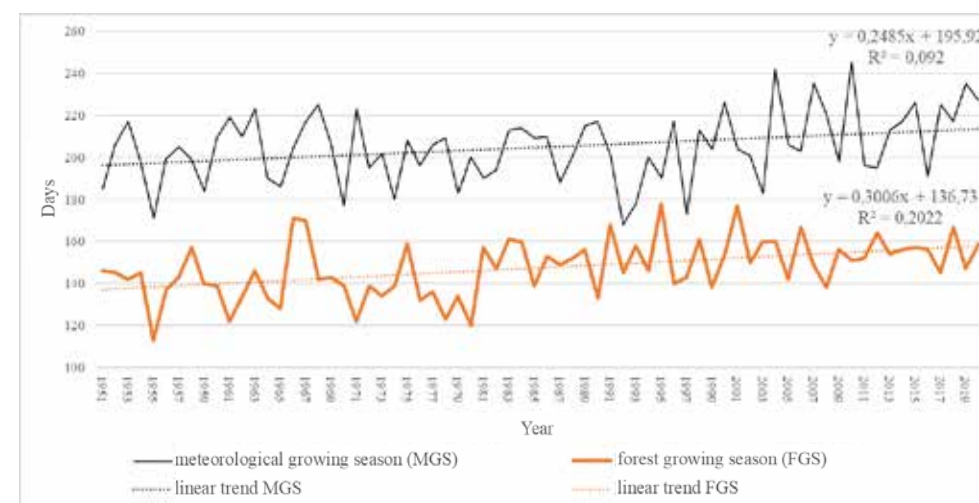

Figure 8.16. Duration of the meteorological growing season (MGS) and the forest growing season (FGS) in Białowieża Forest in the period 1951–2020

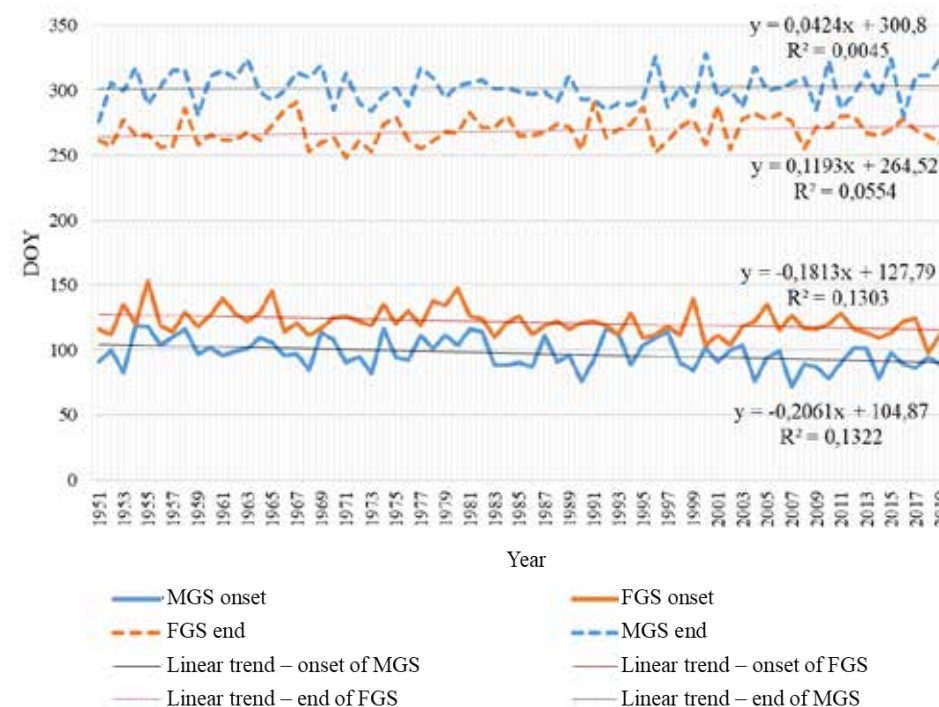

Figure 8.17. Start and end dates of the meteorological growing season (MGS) and the forest growing season (FGS) in Białowieża Forest in the years 1951–2020. DOY – day of year

8.3.2. Meteorological Conditions in Białowieża Forest in the period 2016–2020

8.3.2.1. Duration of the Meteorological Growing Season and the Forest Growing Season

The meteorological growing season (MGS) and the forest growing season (FGS) in Białowieża Forest lengthened in the period 1951–2020 (Fig. 8.16). During this period, the length of the MGS was 205 days on average, while the length of the FGS was 147 days.

During 2016–2020, the MGS generally began in late March and early April. It started earliest in 2017, on 27.03 (DOY, i.e., day of year, 86) and latest in 2020, on 06.04 (DOY 97). The MGS usually ended in November. It ended latest in 2019, on 20.11 (DOY 324), and earliest in 2016, on 6.10 (DOY 280). In 2016–2020, the FGS began in late April and early May, with the earliest start in 2018, on 8.04 (DOY 98) and the latest start in 2017, on 04.05 (DOY 124). The end of the FGS was in late September and early October. The earliest end of the FGS was in 2019, on 16.09 (DOY 259) and the latest in 2016 and 2020, on 04.10 (in both cases, DOY 278) (Fig. 8.17). In the five years considered, the MGS lasted longest in 2019 (235 days) and shortest in 2016 (191 days). It was thus shorter than the 1951–2020 multi-year average (205 days) mentioned above. The FGS was shortest in 2017 (145 days) and longest in 2018 (167 days). An interesting observation is that the changes in MGS and FGS do not occur at the same pace and vary from year to year (Tab. 8.17).

Table 8.7. Duration of the meteorological growing season (MGS) and the forest growing season (FGS) in Białowieża Forest in the period 2016–2020

Year	MGS (days)	FGS (days)
2016	191	156
2017	225	145
2018	217	167
2019	235	147
2020	227	159
Long-term average for the period 1951–2020	205	147

8.3.2.2. Thermal Conditions

Based on the classification of thermal conditions in Białowieża Forest in 2016–2020 according to the method of Lorenc (2000), it was found that 2019 and 2020 were anomalously warm with mean annual temperatures of 9.0°C. The coldest year was 2017 with an annual temperature of 7.7°C, which was classified as slightly warm. 2016 and 2018 were warm years (Tab. 8.8).

Table 8.8. Classification of thermal conditions in 2016–2020 based on comparison with the long-term average for the period 1951–2020 in Białowieża Forest according to the method of Lorenc (2000). Mean – the average value of mean annual temperatures in the period 1951–2020, SD – the value of standard deviation from the mean value of mean annual temperatures in the period 1951–2020

Class	Standard deviation	Temperature range (°C)	Description	Mean annual temperature (°C)
1	≥ mean + 2.5 SD	≥ 9.5	extremely warm	
2	mean + 2.5 SD	8.9–9.4	anomalously warm	2019: 9.0°C 2020: 9.0°C

3	mean + 2 SD	8.3–8.8	very warm	
4	mean + 1.5 SD	7.8–8.2	warm	2016: 7.8°C 2018: 8.2°C
5	mean + 1 SD	7.3–7.7	slightly warm	2017: 7.7°C
6	mean + 0.5 SD	6.2–7.2	normal	
7	mean - 1 SD	5.7–6.1	slightly cold	
8	mean - 1.5 SD	5.1–5.6	cold	
9	mean - 2 SD	4.6–5	very cold	
10	mean - 2.5 SD	4.1–4.5	anomalously cold	
11	≤ mean - 2.5 SD	≤ 4.0	extremely cold	

8.3.2.3. Precipitation Conditions

The classification of precipitation in Białowieża Forest in 2016–2020 according to the method of Kaczorowska (1962) showed that 2016 was very wet compared to the long-term average for the period 1951–2020, which was 636.1 mm year⁻¹, exceeding this value by 200 mm. 2017 was a wet year with precipitation 140 mm above the long-term average. 2018 and 2020 were dry, while 2019 was very dry, recording only 458.8 mm of annual precipitation (Tab. 8.9).

Table 8.9. Classification of precipitation conditions in 2016–2020 based on a comparison with the long-term average for the period 1951–2020 in Białowieża Forest according to the method of Kaczorowska (1962)

Class	Range (%)	Range (mm)	Description	Total precipitation (mm)
1	< 50%	< 318	extremely dry	
2	50–75%	318–477.0	very dry	2019: 458.8 mm
3	75–90%	477.1–572.4	dry	2018: 556.3 mm 2020: 572.0 mm
4	90–110%	572.5–699.7	normal	
5	110–125%	699.8–795.1	wet	2017: 772.9 mm
6	125–150%	795.2–954.1	very wet	2016: 833.2 mm
7	> 150%	> 954.1	extremely wet	

8.3.2.4. Climate Diagram

The average annual temperature in the period 1951–2020 in Białowieża Forest was 6.7°C. In relation to this, the years 2016–2020 exceeded this value. The warmest months were July and August. In 2016–2020, June was among the warmest months, in addition to July and August. In both 2019 and 2020, June was the warmest month of the year. During 1951–2020, the coldest months were January and February. In 2016–2020, these months were also the coldest. The year 2020 was exceptional in this respect, as there was no month in which the mean daily air temperature fell below 0°C (Tab. 8.10, Fig. 8.18). The variation coefficient of monthly mean temperature was highest in the winter months, especially in March. Moreover, the variation coefficient was very high in February (91%), November (77%), and January (67%), while the lowest variation coefficient occurred in the summer months (< 10%).

The highest average monthly precipitation during 1951–2020 occurred in July. High average precipitation totals also occurred in June, August, and May. The lowest average monthly totals occurred in the first quarter of the year, i.e., January, February, and March. During 2016–2020, the distribution of precipitation varied. In 2016 and 2017, high precipitation levels of more than 100 mm were recorded. These values were recorded in October and July in 2016 and in September and October in 2017 (Tab. 8.10, Fig. 8.18). In the period 2016–2020, the distribution of precipitation appeared to vary more than the distribution of temperature. The mean variation coefficient of precipitation for the year was 25%, while the mean variation coefficient of temperature was 9%. The largest variation in precipitation occurred in October (variation coefficient = 94%) and in February, April, July, and September (variation coefficient > 60%).

Table 8.10. Mean air temperatures and precipitation totals, monthly and annual, in Białowieża Forest during 2016–2020, compared with long-term averages for the period 1951–2020

Year\ Month	I	II	III	IV	V	VI	VII	VIII	IX	X	XI	XII	Annual mean
1951–2020 (mean)	-4.3	-3.6	0.2	6.8	12.6	16.1	17.7	16.6	11.7	6.7	2.1	-1.9	6.7
2016	-5.3	2	2.5	8.2	14.1	17.8	18.4	17.1	12.6	5.5	1.2	-0.4	7.8
2017	-5.5	-2.7	4.5	6.1	13	16.5	17.5	17.7	12.7	7.8	3.3	1.3	7.7
2018	-1.6	-5.1	-1.7	11.5	15.9	18.1	19.4	18.9	13.8	7.7	2.4	-0.5	8.2
2019	-4.3	1.5	3.7	8.3	13.1	21	17.6	17.9	12.5	9.3	5.2	2	9.0
2020	1.3	2	2.8	6.8	10.9	19	18.1	18.7	13.7	9.3	4.6	0.4	9.0

	1951–2020 (mean)	38.3	33.4	35.2	42.0	63.7	76.8	82.7	68.5	57.4	47.6	45.7	44.8	636.1
Monthly total precipitation	2016	47.8	59.5	65.3	48.2	61.5	67.5	167.7	61.6	15.7	124	63.2	51.2	833.2
	2017	25.6	59	41.9	72.4	33.6	81.9	87	52.9	115.6	109.6	40.5	52.9	772.9
	2018	38.5	17.4	26.9	27.2	31.2	37.6	78.7	82.1	49.1	48.9	26.1	89.9	553.6
	2019	63.8	9.3	43.9	13.6	50.3	29.3	51.6	42.3	54.6	18.5	42.3	39.3	458.8
	2020	36.4	41	30.2	14.4	68.9	115.7	35	80.3	39.2	49.9	28.9	32.1	572.0

8.3.2.5. Hydrothermal Conditions

The long-term average of the Selianinov coefficient (k) during 1951–2020 was 1.6, within the optimum of 1.5–2.2 for lowland forests (Malzahn et al. 2009). The years 2016–2017 were also within the optimum with k values of 1.8 and 2.0. In contrast, years 2018–2020 had a coefficient k that was well below the long-term average and below the optimal value. The lowest result was recorded in 2019 and 2018 (Tab. 8.11).

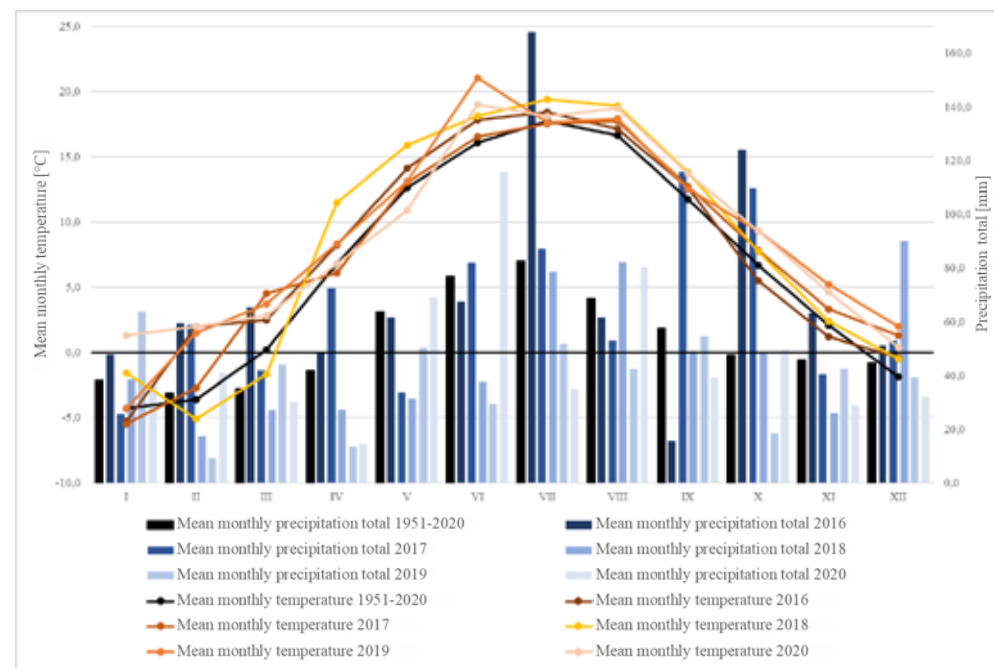

Figure 8.18. Climate diagram for the meteorological station IMGW Białowieża in the period 2016–2020 in comparison with the long-term average values for the period 1951–2020

Table 8.11. Values of the Selianinov coefficient in Białowieża Forest in 2016–2020 compared to the long-term average for the period 1951–2020

Year	Selianinov coefficient
2016	1.8
2017	2.0
2018	1.0
2019	0.94
2020	1.4
Long-term average for the period 1951–2020	1.6

8.3.2.6. Winter Conditions

Since 1951, when the calculation of the long-term average was started, cyclic changes in the value of the winter severity index and a downward trend in its value have been observed (Fig. 8.19). The long-term average winter severity index for the period 1951–2020 was 4.1. In 2016–2020, the winter severity index had values between 1.1 and 3.7 (Tab. 8.12), indicating that winters in this period were milder than the long-term average. The winter of 2019/2020 was strikingly mild. The mean winter temperature at that time was 2°C and the winter severity index was 1.1. The winters of 2016/2017 and 2017/2018 were more severe than the winters of 2015/2016 and 2018/2019, and the winter of 2017/2018 was close to the long-term average. Winter precipitation totals showed fluctuations. The long-term average was 150 mm. The winters of 2017/18 and 2019/20 were close to the long-term average in terms of precipitation totals, while the winters of 2015/2016 and 2018/2019 had higher precipitation totals (Tab. 8.12).

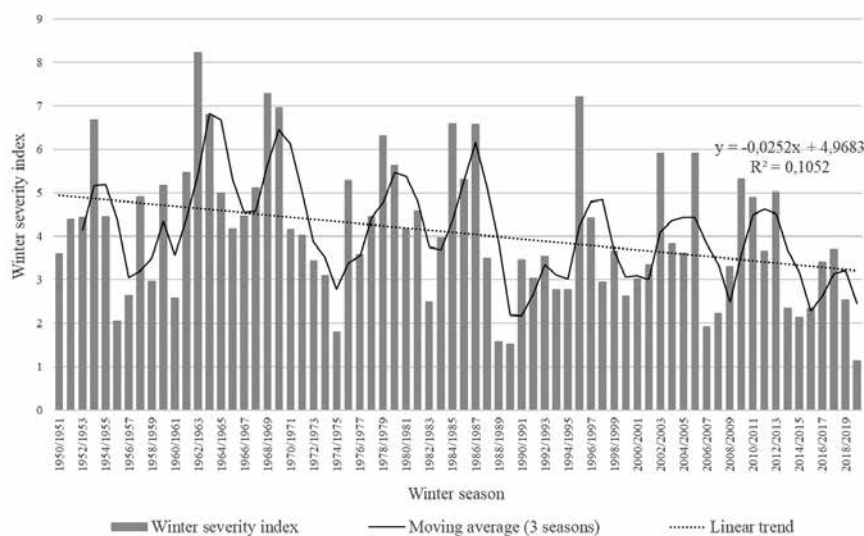

Figure 8.19. Changes in the winter severity index in Białowieża Forest in the period 1951–2020. No data available for 1956

Table 8.12. Indices describing winters in Białowieża Forest in 2016–2020 compared to the long-term average for the period 1951–2020

Year	Winter severity index	Number of winter days	Number of frosty days	Number of very frosty days	Winter mean temperature (°C)	Winter mean minimum temperature (°C)	Precipitation total (mm)
2015/2016	2.3	42	22	13	0.5	-12.3	231.2
2016/2017	3.4	63	40	19	-1	-13.8	177.7
2017/2018	3.7	69	41	21	-1.8	-15.4	135.7
2018/2019	2.5	50	32	8	0.1	-11.4	206.9
2019/2020	1.1	29	2	0	2	-6.7	146.9
Long-term average for the period 1951–2020	4.1	71	44	24	-2.4	-16.9	149.6

8.3.2.7. Synthetic Meteorological Characteristics of the Individual Years in the Period 2016–2020

Meteorological conditions during 2016–2020 appeared to follow several climate trends observed during the 1951–2020 multi-year period. There was a significant increase in annual mean temperature and consequently a lengthening of the meteorological and the forest growing season. The amount of precipitation varied. The first two years in 2016–2020 were wet and very wet, with annual precipitation above the long-term average for 1951–2020, and the following three years were dry and very dry, with annual precipitation below the long-term average for 1951–2020. High variability was observed in the analysis of monthly precipitation, especially in the winter months. The Selianinov hydrothermal coefficient was at the optimum in 2016–2017, while it was below the optimum for lowland forests (Malzahn et al. 2009) in 2018–2020. Winter conditions during the studied period were also variable. The winter of 2017/2018 was the most severe. The mildest winter conditions were observed during the winters of 2015/2016, 2018/2019, and 2019/2020, when average temperatures were above zero. In summary, the individual years and winter seasons during the 2016–2020 study period can be characterised as follows: (1) in terms of precipitation – wet (2016 and 2017), dry (2018 and 2020), and very dry (2019); (2) in terms of thermal conditions – warm (2016, 2017 and 2018), and anomalously warm (2019 and 2020); (3) in terms of winter severity – normal (winter 2017/2018), mild (winters 2015/2016, 2016/2017, and 2018/2019), and

extremely mild (winter 2019/2020); (4) in terms of winter precipitation – normal (winters 2017/2018 and 2019/2020), wet (winter 2016/2017), and very wet (winters 2015/2016 and 2018/2019) (Tab. 8.13).

Table 8.13. Synthetic characteristics of meteorological conditions in Białowieża Forest in 2016–2020. MGS – meteorological growing season

MGS/Winter	Precipitation	Temperature
winter 2015/2016	very wet	mild
MGS 2016	very wet	warm
winter 2016/2017	wet	mild
MGS 2017	wet	slightly warm
winter 2017/2018	normal	normal
MGS 2018	dry	warm
winter 2018/2019	very wet	mild
MGS 2019	very dry	anomalously warm
winter 2019/2020	normal	extremely mild
MGS 2020	dry	anomalously warm

8.4. Discussion

Selected tree species in the main habitat types of Białowieża Forest responded to the variable meteorological conditions in 2016–2020 with different changes in stem circumference (Fig. 8.14–8.15, Tab. 8.5–8.6). It should be added that both significant anomalies of meteorological conditions (2018–2020) and rather average conditions (2016–2017) were observed during this period (Tab. 8.13).

The highest stem circumference growth during 2016–2020 was recorded for elm in oak-lime-hornbeam forests. Most taxa had the highest stem circumference growth during the 2017 meteorological growing season (a wet and slightly warm year), which subsequently declined to varying degrees and reached a minimum in 2019, while in 2020 it reached values approaching those of 2018. Only spruce and birch in oak-lime-hornbeam forests and ash in alder bog forests and riparian forests continued their downward trend in stem circumference growth in 2020. Interestingly, alder in alder bog forests and riparian forests reached its maximum stem circumference growth in 2018, a year characterised by a negative water balance during the summer months in Europe (Buras et al. 2020). A study of 21 species showed that the record heatwave of 2018 in Europe did not reduce radial growth of trees, but only increased temporary stem shrinkage due to water deficit (Salomón et al. 2022). In 2016–2020, hornbeam in oak-lime-hornbeam forests proved to be exceptional compared to other tree

species in Białowieża Forest, showing the maximum stem circumference growth in 2020 (Tab. 8.4). This complex tree growth response may reflect a wide variation in thermal and hydrological conditions during the meteorological growing seasons and winter months in the period studied, with each season having its own characteristics (Tab. 8.13). Winter conditions preceding the growing season also have a significant influence on the dynamics of tree radial growth in Białowieża Forest (Yermokhin and Savel'ev 2011; Yermokhin et al. 2017), so the observed variability of winter conditions was certainly not negligible for the recorded stem circumference changes during cambium activity. This also highlights the importance of multi-year data series in dendrometer studies (van der Maaten et al. 2013), especially when there are years with particular meteorological conditions in a given period compared to average years.

The recorded changes in stem circumference (Fig. 8.3–8.13) show a marked difference between the winter and growing seasons. This observation is closely related to the different processes that determine stem volume dynamics during the period of radial growth and during the cambial dormancy (Herzog et al. 1995; Downes et al. 1999; Zweifel and Häsler 2000; Deslauriers et al. 2003; Turcotte et al. 2009; van der Maaten et al. 2013; Nalevanková et al. 2018). The observed increase in stem circumference after rainfall during the growing season (Fig. 8.4–8.13) is consistent with the results of other studies (Downes et al. 1999; van der Maaten et al. 2013). However, it should be noted that the increase in stem circumference associated with rainfall may indicate both the importance of water for radial growth (Deslauriers et al. 2003) and reversible stem swelling when transpiration is impeded due to high relative humidity (Herzog et al. 1995). The changes in stem circumference recorded during the winter season in the studied period 2016–2020 (Fig. 8.3–8.13) confirm the phenomenon that tree stems shrink during frost and return to their original size at higher temperatures. This process is related to water transport from the living cells to the xylem and vice versa, which protects the living cells from freezing (Zweifel and Häsler 2000). The tree species studied responded differently to winter conditions in Białowieża Forest (Fig. 8.3). Similar to other studies (Zweifel and Häsler 2000), the changes in stem circumference observed during the winter season were very significant. It is worth noting that these changes were more intense compared to those observed during the growing season (Fig. 8.3–8.13).

When analysing dendrometer data, one should be aware that they record not only actual, permanent radial growth, but also reversible stem circumference changes unrelated to xylogenesis (Herzog et al. 1995; Zweifel and Häsler 2000; Deslauriers et al. 2003, 2007a; Korpela et al. 2008; Mäkinen et al. 2008; Turcotte et al. 2009; van der Maaten et al. 2013; Nalevanková et al. 2018; Klisz et al. 2020; see „Introduction”). Temporal changes in stem circumference may not only be influenced by processes directly related to changes in the amount of water in the phloem and cambium (e.g., Herzog et al. 1995; Zweifel and Häsler 2000; Deslauriers et al. 2003; Mäkinen et al. 2008). Stem circumference may also increase due to unseen damage to the trunk that allows water to enter and split the trunk from the inside when it freezes in winter. Despite these problems, dendrometers are widely used tools to study the relationship between stem size variation and various environmental factors, although these devices provide data that are complex to interpret (e.g., van der Maaten et al. 2013; Herrmann et al. 2016; Nalevanková et al. 2018; Klisz et al. 2020; Salomón et al. 2022; see „Introduction”).

8.5. Conclusion

The dendrometer data collected as part of the ForBioSensing project undoubtedly have great potential to increase knowledge about the current growth of the main tree species of Białowieża Forest under different habitat conditions. However, it should be noted that the studies should be much longer, because long-term observations increase the chance of detecting regularities in tree growth response to environmental conditions, such as meteorological factors (van der Maaten et al. 2013), which often show enormous fluctuations from year to year (see Tab. 8.13). The results presented in this chapter may indicate some trends, but these can only be confirmed after many years of meteorological and dendrometric observations. The radial growth of trees is influenced by many factors (Fritts 1976). Therefore, to confirm the actual influence of each meteorological factor considered, tree growth response would have to be recorded several times under similar meteorological conditions. The longer the period of empirical data collection, the clearer the trend in response of individual tree species to specific conditions (van der Maaten et al. 2013). It should also be noted that it is quite difficult to integrate the response of ten tree species into a single trend. Therefore, it is fair to say that the more species a forest stand contains, the more complex its response to specific meteorological conditions is likely to be. In the context of ongoing, complex, and multi-directional climate change (Giorgi et al. 2004; IPCC 2007; Zajączkowski et al. 2013), this may be a key issue for the conservation and management of forest resources not only of Białowieża Forest, but also of Europe, which requires further comprehensive research.

Acknowledgements

We thank the Regional Directorate for Environmental Protection in Białystok and the Białowieża National Park for permission to establish study plots with dendrometers in nature reserves and in the Białowieża National Park. We are grateful to Jiří Kučera for valuable discussions and technical support throughout the research. We thank the following individuals for their assistance in field data collection, database compilation and updating, and preparation of ongoing reports at various stages of the project during 2015–2020: Lander Amado, Michał Androsiuk, Paula Całusińska, Joanna Chęcka, Karolina Ciechańska-Sędłak, Alicja Dołkin, Krzysztof Gaszewski, Alicja Jasińska, Radosław Kanabus, Grzegorz Ledworuch, Andrzej Lipiński, Paweł Nowak, Andoni Ortiz Garcia, Bartosz Piekło, Karol Rzczycki, Paweł Sańczyk, Jakub Słowik, Adam Szulc, Ander Urdapilleta Iparraguirre, Adrian Wasiluk. Our special thanks go to Paweł Nowak for his understanding and invaluable support during the writing and editing phases of the manuscript.

References

- Allen C.D., Macalady A.K., Chenchouni H., Bachelet D., McDowell N., Vennetier M., Kitzeberger T., Rigling A., Breshears D.D., Hogg E.H., Gonzalez P., Fensham R., Zhang Z., Castro J., Demidova N., Lim J.-H., Allard G., Running S.W., Semerci A., Cobb N. 2010. A global overview of drought and heat-induced tree mortality reveals emerging climate change risks for forests. *Forest Ecology and Management*, 259: 660–684. DOI: 10.1016/j.foreco.2009.09.001.
- Anderegg W.R.L., Hicke J.A., Fisher R.A., Allen C.D., Aukema J., Bentz B., Hood S., Lichstein J.W., Macalady A.K., McDowell N., Pan Y., Raffa K., Sala A., Shaw J.D., Stephenson N.L., Tague C., Zeppel M. 2015. Tree mortality from drought, insects, and their interactions in a changing climate. *New Phytologist*, 208: 674–683. DOI: 10.1111/nph.13477.
- Bartoszek K., Węgrzyn A., Kaszewski B.M. & Siłuch M. 2012. Porównanie wybranych metod wyznaczania dat początku i końca okresu wegetacyjnego na przykładzie Lubelszczyzny. [Comparison of selected methods for determining the beginning and end dates of the growing season on the example of Lublin region.] *Przegląd Geofizyczny*, 1: 124–134.
- Biondi F. & Hartsough P. 2010. Using automated point dendrometers to analyse tropical treeline stem growth at Nevado de Colima, Mexico. *Sensors (Basel, Switzerland)*, 10: 5827–5844. DOI: 10.3390/s100605827.
- Buras A., Rammig A. & Zang C.S. 2020. Quantifying impacts of the 2018 drought on European ecosystems in comparison to 2003. *Biogeosciences*, 17: 1655–1672. DOI: 10.5194/bg-17-1655-2020.
- Deslauriers A., Anfodillo T., Rossi S. & Carraro V. 2007a. Using simple causal modelling to understand how water and temperature affect daily stem radial variation in trees. *Tree Physiology*, 27: 1125–1136. DOI: 10.1093/treephys/27.8.1125.
- Deslauriers A., Morin H., Urbinati C. & Carrer M. 2003. Daily weather response of balsam fir (*Abies balsamea* (L.) Mill.) stem radius increment from dendrometer analysis in the boreal forests of Quebec (Canada). *Trees-Structure and Function*, 17: 477–484. DOI: 10.1007/s00468-003-0260-4.
- Deslauriers A., Rossi S. & Anfodillo T. 2007b. Dendrometer and intra-annual tree growth: What kind of information can be inferred? *Dendrochronologia*, 25: 113–124. DOI: 10.1016/j.dendro.2007.05.003.
- Dobbs R.C. & Scott D.R.M. 1971. Distribution of Diurnal Fluctuations in Stem Circumference of Douglas-fir. *Canadian Journal of Forest Research*, 1: 80–83. DOI: 10.1139/x71-010.
- Downes G., Beadle, C. & Worledge D. 1999. Daily stem growth patterns in irrigated *Eucalyptus globulus* and *E. nitens* in relation to climate. *Trees*, 14: 102–111. DOI: 10.1007/PL00009752.
- Drew D.M. & Downes G.M. 2009. The use of precision dendrometers in research on daily stem size and wood property variation: A review. *Dendrochronologia* 27: 159–172. DOI: 10.1016/j.dendro.2009.06.008. DOI: 10.1016/j.dendro.2009.06.008.
- Fritts H.C. 1976. *Tree Rings and Climate*. Academic Press, London.
- Giorgi F., Bi X. & Pal J. 2004. Mean, interannual variability and trends in a regional climate change experiment over Europe. II: climate change scenarios (2071–2100). *Climate Dynamics*, 23: 839–858. DOI: 10.1007/s00382-004-0467-0.
- Herrmann V., McMahon S.M., Detto M., Lutz J.A., Davies S.J., Chang-Yang C.-H. Anderson-Teixeira K.J. 2016. Tree Circumference Dynamics in Four Forests Characterized Using Automated Dendrometer Bands. *Plos One*, 11: e0169020. DOI: 10.1371/journal.pone.0169020. DOI: 10.1371/journal.pone.0169020.
- Herzog K.M., Häslner R. & Thum R. 1995. Diurnal changes in the radius of a subalpine Norway spruce stem: their relation to the sap flow and their use to estimate transpiration. *Trees*, 10: 94–101. DOI: 10.1007/BF00192189.

- IPCC 2007. Climate Change 2007: The Physical Science Basis. Contribution of Working Group I to the Fourth Assessment Report of the Intergovernmental Panel on Climate Change. Cambridge University Press, Cambridge.
- Jendrzejcak E. 2005. Ocena częstości występowania pogody posusznej oraz wybitnie wilgotnej w wybranych miejscowościach Polski w maju. [Assessment of the frequency of dry and extremely wet weather in selected places in Poland in May.] Woda-Środowisko-Obszary Wiejskie, 5, z. spec.: 157–169.
- Ježík M., Blaženc M., Kučera J., Strelcová K. & Dítmarová L. 2016. The response of intra-annual stem circumference increase of young European beech provenances to 2012–2014 weather variability. iForest – Biogeosciences and Forestry, 9: 960–969. DOI: 10.3832/ifor1829-009.
- Kaczorowska Z. 1962. Opady w Polsce w przekroju wieloletnim – Tendencje, okresowość oraz prawdopodobieństwo niedoboru i nadmiaru opadów. [Precipitation in Poland in a multi-year perspective – Trends, periodicity and the likelihood of precipitation deficit and excess.] Prace Geograficzne – Polska Akademia Nauk. Instytut Geografii, 33.
- King G., Fonti P., Nievergelt D., Büntgen U. & Frank D. 2013. Climatic drivers of hourly to yearly tree radius variations along a 6°C natural warming gradient. Agricultural and Forest Meteorology, 168: 36–46. DOI: 10.1016/j.agrformet.2012.08.002.
- Klisz M., Buttò V., Rossi S., Morin H. & Jastrzębowski S. 2020. Intra-annual stem size variations converge across marginal populations of European beech. Trees, 34: 255–265. DOI: 10.1007/s00468-019-01915-5.
- Korpela M., Mäkinen H., Sulkava M., Nöjd P. & Hollmen J. 2008. Smoothed Prediction of the Onset of Tree Stem Radius Increase Based on Temperature Patterns. [In:] Boulicaut, J.F., Berthold, M.R. & Horvath, T. (eds.) Discovery Science, Proceedings, pp. 100–111.
- Kraft G. 1884. Beiträge zur Lehre von den Durchforstungen, Schlachtstellungen und Lichtungshieben. Klindworth's Verlag, Hannover.
- Lorenc H. 2000. Termiczno-opadowa ocena klimatycznych sezonów roku w Polsce oraz tendencje czasowo-przestrzenne. [Thermal and precipitation assessment of climatic seasons of the year in Poland and temporal and spatial trends.] Projekt badawczy M-9, IMGW, Maszynopis. [Research Project M-9, IMGW, Typescript.].
- Lövdahl L. & Odin H. 1992. Diurnal changes in the stem diameter of Norway spruce in relation to relative humidity and air temperature. Trees, 6: 245–251. DOI: 10.1007/BF00224344.
- Mäkinen H., Seo J.-W., Nöjd P., Schmitt U. & Jalkanen R. 2008. Seasonal dynamics of wood formation: a comparison between pinning, microcoring and dendrometer measurements. European Journal of Forest Research, 127: 235–245. DOI: 10.1007/s10342-007-0199-x.
- Malzahn E., Kwiatkowski W. & Pierzgalski E. 2009. Przyroda nieożywiona. [In:] Okołów C., Karaś M. & Bołbot A. (eds.) Białowiecki Park Narodowy. Poznać – Zrozumieć – Zachować [Białowieża National Park. Know it – Understand it – Protect it]: 17–36. Białowiecki Park Narodowy, Białowieża.
- Nalevanková P., Ježík M., Sitková Z., Vido J., Leštianska A. & Střelcová K. 2018. Drought and irrigation affect transpiration rate and morning tree water status of a mature European beech (*Fagus sylvatica* L.) forest in Central Europe. Ecohydrology 11: e1958. DOI: 10.1002/eco.1958.
- Olszewski J.L., Żarnowiecki G. & Krzak P. 1992. Ostrość termiczna zim na Świętym Krzyżu. [Thermal severity of winters at Święty Krzyż.] Rocznik Świętokrzyski, 19: 145–151.
- Rossi S., Deslauriers A., Anfodillo T., Morin H., Saracino A., Motta R. & Borghetti M. 2006. Conifers in cold environments synchronize maximum growth rate of tree-ring formation with day length. New Phytologist, 170: 301–310. DOI: 10.1111/j.1469-8137.2006.01660.x.
- Salomón R.L., Peters R.L., Zweifel R., Sass-Klaassen U.G.W., Stegehuis A.I., Smiljanic M., Poyatos R., Babst F., Cienciala E., Fonti P., Lerink B.J.W., Lindner M., Martinez-Vilalta J., Mencuccini M., Nabuurs G.-J., van der Maaten E., von Arx G., Bär A., Akhmetzhanov L., Balanzategui D., Bellan M., Bendix J., Berveiller D., Blaženc M., Čada V., Carraro V., Cecchini S., Chan T., Conedera M., Delpierre N., Delzon S., Dítmarová L., Dolezal J., Dufrene E., Edvardsson J., Ehekircher S., Forner A., Frouz J., Ganthaler A., Gryc V., Güney A., Heinrich I., Hentschel R., Janda P., Ježík M., Kahle H.-P., Knüsel S., Krejza J., Kuberski L., Kučera J., Lebourgeois F., Mikoláš M., Matula R., Mayr S., Oberhuber W., Obojes N., Osborne B., Paljakka T., Plichta R., Rabbel I., Rathgeber C.B.K., Salmon Y., Saunders M., Scharnweber T., Sitková Z., Stangler D.F., Stereńczak K., Stojanović M., Střelcová K., Světlík J., Svoboda M., Tobin B., Trotsiuk V., Urban J., Valladares F., Vavřík H., Vejpustková M., Walthert L., Wilmking M., Zin E., Zou J., Steppe K. 2022. The 2018 European heatwave led to stem dehydration but not to consistent growth reductions in forests. Nature Communications, 13: 28. DOI: 10.1038/s41467-021-27579-9.
- Turcotte A., Morin H., Krause C., Deslauriers A. & Thibeault-Martel M. 2009. The timing of spring rehydration and its relation with the onset of wood formation in black spruce. Agricultural and Forest Meteorology, 149: 1403–1409. DOI: 10.1016/j.agrformet.2009.03.010.
- Turcotte A., Rossi S., Deslauriers A., Krause C. & Morin H. 2011. Dynamics of depletion and replenishment of water storage in stem and roots of black spruce measured by dendrometers. Frontiers in plant science, 2: 21 (1–8). DOI: 10.3389/fpls.2011.00021.
- van der Maaten E., Bouriaud O., van der Maaten-Theunissen M., Mayer H. & Spiecker H. 2013. Meteorological forcing of day-to-day stem radius variations of beech is highly synchronic on opposing aspects of a valley. Agricultural and Forest Meteorology, 181: 85–93. DOI: 10.1016/j.agrformet.2013.07.009.
- Vieira J., Rossi S., Campelo F., Freitas H. & Nabais C. 2013. Seasonal and daily cycles of stem radial variation of *Pinus pinaster* in a drought-prone environment. Agricultural and Forest Meteorology, 180: 173–181. DOI: 10.1016/j.agrformet.2013.06.009.
- Yermokhin M.V., Mychko V.E., Knysh N.V. & Lukin V.V. 2017. Rekonstrukciya dinamiki vysokovozrastnykh shirokolistvennykh lesov Belovezhskoi Pushchi. Botanika (Issledovaniya), 6: 67–83.
- Yermokhin M.V. & Savel'ev V.V. 2011. Vliyanie klimaticheskikh faktorov na radial'nyi prirost derev'ev sosny, eli i duba v Belovezhskoi Pushche. [In:] Osobo okhranyaemye prirodnye territorii Belarusi. Issledovaniya, pp. 28–44. Belorusskii Dom pečati, Minsk.
- Zajączkowski J., Brzeziecki B., Perzanowski K. & Kozak I. 2013. Wpływ potencjalnych zmian klimatycznych na zdolność konkurencyjną głównych gatunków drzew w Polsce. [Impact of potential climate changes on the competitive ability of major tree species in Poland.] Sylwan, 157(4): 253–261. DOI: 10.26202/sylwan.2012134.
- Zweifel R. & Häsler R. 2000. Frost-induced reversible shrinkage of bark of mature subalpine conifers. Agricultural and Forest Meteorology, 102: 213–222. DOI: 10.1016/S0168-1923(00)00135-0.
- Zweifel R., Item H. & Häsler R. 2000. Stem radius changes and their relation to stored water in stems of young Norway spruce trees. Trees-Structure and Function, 15: 50–57. DOI: 10.1007/s004680000072.

III. Status and dynamics of Białowieża Forest stands - analysis based on remote sensing data

9. Use of remote sensing data to assess the dynamics of selected characteristics of Białowieża Forest stands in 2015-2019

**K. Stereńczak¹, B. Kraszewski¹, A. Kamińska¹, Ż. Piasecka¹,
M. Lisiewicz¹, M. Białczak¹, M. Mielcarek¹, A. Modzelewska¹,
R. Sadkowski¹, K. Kędra¹**

¹ Forest Research Institute, Department of Geomatics, Sękocin Stary, 3 Braci Leśnej St., 05-090 Raszyn
{k.stereńczak, b.kraszewski, a.kaminska, z.piasecka, m.lisiewicz, m.białczak, m.mielcarek,
a.modzelewska, r.sadkowski, k.kedra}@ibles.waw.pl

Abstract

This chapter is, in a sense, a synthesis and summary of the remote sensing analyses carried out during the project. The remote sensing data obtained in the following years of the project made it possible to determine the direction of changes in the stands of the Białowieża Forest.

Based on the remote sensing data obtained, a number of stand characteristics were determined, which were then followed by an in-depth analysis of changes in species composition and stand structure. The natural processes observed include: changes in the spruce stands (including the decline of spruce caused by the bark beetle outbreak), the appearance of natural regeneration, the formation of gaps, the enlargement or overgrowth of existing gaps, as well as changes in the proportion of individual species and structural changes in the stands. By using several time series of different remote sensing data, a comprehensive picture of the changes in forest stands and their dynamics in the Białowieża Forest (BF) was obtained.

This chapter presents the main results of the analyses carried out using a combination of remote sensing data from different sources (LIDAR, satellite images, aerial photographs) and ground-based measurements. The obtained results are not only of scientific value, but can also be a valuable source of information for the administrative institutions managing the Białowieża Forest area.

Keywords: taxonomic characteristics, stand dynamics, remote sensing

9.1. Introduction

Effective management and conservation of forest areas requires timely and reliable information (Wulder et al. 2008; Heinzel and Koch 2012). Usually, such information is obtained through field assessments and ground-based inventories using different types of sample plots (Cohran 1977). Ground-based forest inventory methods are very labour-intensive, expensive and impossible to implement in some situations (wetlands, strict protected areas, etc.) (Dalponte et al. 2008). For this reason, any new tools, data and methods that are possible for this work are always met with great interest and attempts to apply them in practise. This also applies to photogrammetry/remote sensing tools and data, which of course attract interest not only from scientists but also from institutions that manage forests and protect nature in forest areas (Potapov et al. 2008).

The application of remote sensing and photogrammetric techniques in forestry has a very long and rich history (Będkowski 2015). Foresters quickly realised that remote sensing techniques have a very great potential for obtaining forest information and started scientific research in this field. One of the first documented attempts to use aerial photographs for forestry purposes dates back to 1887 (Anonymous 1887), when German scientists used balloons to take pictures of a particular forest complex. With the advent of the first aircraft and the development of aviation (first half of the 20th century), more and more works appeared describing the use of aerial photography in forestry. Among other things, the estimation of height and tree volume was the subject of research (Seely 1929, 1935; Spurr 1948). After World War I, advances in cameras and aviation made photogrammetry more widespread, and foresters increasingly appreciated the possibility of using aerial photographs for forest inventories or forest condition assessment. The 1980s and 1990s already saw the development of computer technology and the appearance of the first digital photogrammetric stations (Balenovic et al. 2011), as well as the first attempts to use Airborne Laser Scanning (ALS) for forestry purposes (Sołoduchin 1977, 1979a, 1979b; Nelson et al. 1988). At the beginning of the 21st century, the focus is not only on technological development, significantly improving data availability or reducing data collection costs, but also on working on the automation and optimisation of computational processes (Będkowski 2015).

Remote sensing provides objective, reliable, consistent and up-to-date information on many tree and stand parameters, enabling more effective spatial characterisation of the forest areas under study. Remote sensing can be divided into active and passive techniques. Active remote sensing methods are based on the signal sent by a survey instrument, which, after being reflected by an object, is recorded and converted into a form used for analysis. Examples of active technologies are radar and laser scanners. Widely used in forestry is LiDAR (Light Detection and Ranging), where a laser beam of a certain wavelength sent by the scanner in a certain direction is reflected by an obstacle after hitting it and the information about this reflection is recorded by the scanner. LiDAR data acquired in different ways: terrestrially (TLS - Terrestrial Laser Scanning, MLS - Mobile Laser Scanning, HLS - Handheld Laser Scanning, BLS - Backpack Laser Scanning, etc.) and from the air (UAV - Unmanned Aerial Vehicle scanning; ALS - Airborne Laser Scanning, SLS - Satellite Laser Scanning) are used for biometric measurements of trees and stands. Examples of passive remote sensing are

digital images obtained from different sources, similar to LiDAR data. Passive methods are based on the registration of electromagnetic radiation reflected from objects (optical remote sensing) or emitted from observed objects (thermal remote sensing). Hyperspectral data have the greatest potential in the context of the natural environment. They are characterised by a much higher spectral resolution compared to multispectral data, allowing the detection of more subtle differences between objects (Fassnacht et al. 2016).

Both passive and active remote sensing techniques are widely used in forestry. Active satellite and aerial systems are less sensitive to weather and can also collect data at night because they use the electromagnetic radiation they emit. They also have the advantage of directly providing information on the vertical and horizontal structure of the forest. The variety of systems on the market, the cost and the availability of data mean that the user has a huge range of choice and analysis options. Often, different techniques are combined so that the information derived from remote sensing data is more complete and offers greater measurement, analysis and interpretation possibilities (Packalen and Maltamo 2007; Fassnacht et al. 2016; Kamińska et al. 2018).

Remote sensing systems are characterised by varying spatial, temporal, radiometric and spectral resolution (Lechner et al. 2020). Spatial resolution, defined as Ground Sampling Distance (GSD), is defined as the distance between the centres of two adjacent pixels measured on the ground. Depending on the purpose of the analyses, high-resolution aerial imagery data with 10 cm resolution or low-resolution satellite data with 30 m resolution can be used. Temporal resolution characterises satellite systems and defines the minimum time a satellite system needs to acquire another image of the same area on Earth. Currently, there are constellations of satellites orbiting the Earth that provide images of the entire surface of the Earth every day. Radiometric resolution defines the number of levels into which the range of the signal received by the sensor is divided. Radiometric resolution is expressed in the number of bits (e.g. an 8-bit or 10-bit resolution means that the sensor can show 256 or 1,024 different signal levels respectively). Spectral resolution defines the number of spectral channels that a particular system records. The width of the recorded channel, i.e. the range from the smallest to the largest wavelength of the recorded electromagnetic radiation, is also important. Standard systems record electromagnetic radiation in a few channels (so-called multispectral systems), but there are also systems on the market that record even more than 400 narrow channels (with a wavelength range of about 5 nm) in the range 400-2500 nm. Different systems for collecting forest data have different performance characteristics. Satellite data usually have lower spatial and spectral resolution compared to aerial systems. In addition, in the case of passive data, coverage may be limited due to cloud cover. UAV data has the highest spatial resolution, but a major limitation in its use is the relatively small area for which data is collected during a single flight.

With the right processing of remote sensing data, a lot of information can be gained about forest areas. Airborne laser scanning data have been successfully used to obtain quantitative forest data such as stand volume, tree density, canopy closure, basal area or tree height (Wulder et al. 2008; Stereńczak 2010; White et al. 2013). In general, two approaches are used to determine forest characteristics from airborne laser scanning data. In the first approach, the determination of tree and stand characteristics is based on Individual

Tree Detection (ITD; Hyypä and Inkinen 1999). The result is a vector layer containing the parameters of the tree crowns with their additional features. On this basis, the characteristics of entire stands are determined (Stereńczak and Zasada 2011). In the second approach, ALS data or their derivatives relating to a specific area (often an area for which field measurements have also been made; ABA - Area Based Approach) are analysed and empirical relationships between these data and selected stand characteristics are developed. Many different methods using ABA have been described in the literature. The so-called ABA-PC uses synthetic point clouds (PC) metrics (statistical measures, descriptors) derived from the distribution of height and intensity values of individual points as predictors (Nelson et al. 1988; Næsset 2002). In contrast, the ABA-CHM approach uses metrics derived from the grid level as predictors, which is the Canopy Height Model (CHM; Corona and Fattorini 2008; Lindberg and Hollaus 2012). A third approach, ABA-ITD, uses summary characteristics of individual trees in an area as predictors (Holmgren et al. 2012; Stereńczak and Miścicki 2012). A number of approaches for determining stand separation characteristics have been presented in the literature. The authors of each approach used different methods for processing laser scanning data and different strategies for estimating forest condition characteristics, often obtaining similar results, e.g. for the forest stands volume (Parkitna et al. 2021).

Spectral data from remote sensing allow mostly the analysis of the upper forest layer, i.e. those elements of the forest ecosystem that are visible from a bird's eye view. Remote sensing data are primarily used to identify different land cover classes and, in the case of forests, mainly to identify tree species (Fassnacht et al. 2016; Hycza et al. 2018; Modzelewska et al. 2020, 2021) or tree health (Wulder et al. 2006; Stereńczak et al. 2017, 2019, 2020a; Kamińska et al. 2020, 2021; Nowakowska et al. 2020). Spectral data are often integrated with point data, e.g. with ALS data, whereby structural features are used in addition to reflectance features when analysing specific areas. Consequently, it is possible to obtain higher accuracy of analyses and a wider range of predictions for selected tree and stand parameters (Fassnacht et al. 2016; Kamińska et al. 2018; Laurin et al. 2020). Image data - through appropriate processing into a 2.5 D point cloud (2.5-dimensional space) - also enable the determination of characteristics of individual trees and stands (Bohlin et al. 2012; Mielcarek et al. 2020).

In the ForBioSensing project, several different multitemporal remote sensing datasets were used to inventory and monitor changes in selected elements of the forest environment, in particular: i) species structure, ii) gap dynamics, iii) selected forest stand characteristics, iv) the number of standing dead trees, and v) the vertical structure of the forest stand. The results presented in this chapter result from the use of many methodological solutions, most of which have already been published. Therefore, the description of the methods is brief and includes references to original papers.

9.2. Remote sensing data and their quality control

9.2.1. Remote sensing data

The project acquired a number of different aerial and satellite data sets at different time points (Tab. 9.1).

Table 9.1. Acquisition terms of multispectral imagery, hyperspectral imagery and airborne laser scanning data in the ForBioSensing project

Year	Date of acquisition	Type of remote sensing data
2015	27 June and 24 July	multispectral satellite data
	2-4 July	airborne hyperspectral data
	2-5 July	airborne laser scanning
	5 August	multispectral satellite data
	24-27 August	airborne hyperspectral data
	1-2 October	airborne hyperspectral data
	25, 27 November and 6-7 December	airborne laser scanning
	2016	8-9 August
	6, 9 and 13 September	multispectral satellite data
2017	27 July, 1, 30-31 August	airborne hyperspectral data
	9, 27, 28 September and 2 October	multispectral airborne data
2018	25 March	multispectral airborne data
	1 June	multispectral airborne data
	22 and 30 August	multispectral airborne data
	11 October	multispectral airborne data
2019	24 June	multispectral airborne data
	3-6, 23 August	airborne laser scanning
	24 August	multispectral airborne data
	25, 28, 31 August, 1, 6 September	airborne hyperspectral data
	27 October	multispectral airborne data

9.2.2. Airborne laser scanning

Airborne laser scanning data were collected three times during the project: twice in 2015 (during the leaf-on and leaf-off season) and once during the 2019 in leaf-on season (Tab. 9.1). During the acquisitions in leaf-on season, multispectral aerial images were acquired in parallel, which allowed us to assign values from three spectral channels to each point recorded by laser scanning: near infrared (NIR), red (R) and green (G).

The ALS data from 2015 were acquired using the Riegl LMS-6800i system, which continuously records the laser pulse signal (full waveform). The ALS flights were conducted at an average altitude of 500 m, with an overlap of 40% between strips. The recorded point cloud from the leaf-on season had an average density of 11 pts m⁻², while that from the leaf-off season was 15 pts m⁻². The accuracy error of the point cloud position in the vertical plane was <0.15 m, while the error in the horizontal plane was ≤0.20 m. The point clouds were acquired with a maximum scan angle of ±30°. To cover the entire study area, 135 individual strips were acquired.

Data from 2019 ALS were acquired using a Riegl VQ-780i system, which can also continuously record the laser pulse signal. The flights were conducted at an average height of 650 m, with 20% overlap in the ALS strips. The acquired point cloud had an average density of 19 pts m⁻². The accuracy error of the point cloud position in the vertical plane was <0.15 m, while the error in the horizontal plane was ≤0.20 m. The point cloud was acquired with a maximum scan angle of ±30°. To cover the entire study area, 88 individual strips were recorded.

9.2.3. Hyperspectral imaging

Aerial hyperspectral imagery was acquired five times during the project: three collections in 2015 and one collection in each of 2017 and 2019 (Tab. 9.1). In 2015 and 2017, the data were acquired with HySpex VNIR-1800 and SWIR-384 cameras, which provided images with a spatial resolution of 5 m in the spectral range 400-2500 nm. In 2019, data was collected using a HySpex VS -725 system consisting of a series of scanners - two SWIR-384 and one VNIR-1800 - which provided images with a spatial resolution of 2 m in the spectral range of 400-2500 nm. Each time, the data set was subjected to parametric geometric correction and atmospheric correction.

9.2.4. Multispectral imaging

Multispectral images were the most common data acquired during the project. In 2015 and 2016, these data were acquired from satellite sensors. In 2017-2019, due to too frequent cloud cover over the Białowieża Forest area, data acquired from the air were used for the inventory analyses. The satellite data was from the Pléiades satellite system of Airbus Defence & Space. These satellites are equipped with two sensors - multispectral (MS) and panchromatic (PAN). The multispectral imaging includes four spectral channels in the blue (430-550 nm), green (490-610 nm), red (600-720 nm) and near-infrared (750-950 nm) ranges. The field pixel size of these data is 2 m. The panchromatic channel has a field pixel size of 0.5 m and covers the spectral range from 480 to 830 nm.

Aerial multispectral data were acquired using the DMC II camera (2017 data) and the DMC III camera (2018 and 2019 data). Images were acquired in four spectral channels - blue, green, red and near infrared. The data were acquired with a longitudinal coverage of 80% and a transverse coverage of 70% and a field pixel size of 0.25 m. Based on the images and the Digital Terrain Model with a field pixel size of 1 m, orthophoto was created for the entire area of the Białowieża Forest.

9.2.5. Quality control of remote sensing data

Quality control is one of the most important steps in the process of remote sensing data acquisition and collection. It provides the opportunity to verify the correctness of the data and avoid repeating tedious analysis steps of erroneous remote sensing material. Before any further analysis or production work is carried out, the entered data should first be checked. During quality control, it is advisable to define critical values against which the quality of the data can be checked. Each phase of the control should end with a report showing any deficiencies that need to be improved/corrected. At the same time, the report resulting from the control allows users to quickly familiarise themselves with the basic properties of the data.

As part of the ForBioSensing project, the data provided by the remote sensing flight companies were subject to quality control. In addition, each product developed within the project was subjected to internal quality control at key stages of its development. We aimed to automate most of the quality control steps using our own scripts or dedicated software.

9.2.6. Quality control of airborne laser scanning data

As part of the project, a dedicated tool for automatic quality control of aerial laser scanning data was developed called LasControl (Kraszewski et al. 2020). The tool enable:

- verification of the data stored in the files with regard to their format, range of values, etc.,
- verification of the percentage overlap between adjacent flight strips,
- verification of the point cloud density and its coverage of the flight area,
- verification of the completeness of the data,
- verification of the data accuracy based on the information collected in the field,
- verification of the correctness of the vegetation classification and identification of sites with misclassification of buildings and vegetation.

The LasControl programme made it possible to automatically, quickly and repeatedly check the data supplied by the contractor. At the same time, it was possible to efficiently identify significant gaps or errors in the data. Once the data had been corrected, the automated systems enabled a quick check of the entire data for consistency and accuracy again.

However, not all parameters of airborne laser scanning data quality control could make use of this automated tool. Some elements had to be checked manually. This check consisted of visual verification of the data. The raster products generated from the vector data, i.e. the intensity image, the airborne laser scanning point reflection image and the RGB value image, proved to be helpful. These products made it possible to quickly check the correctness of the individual attributes assigned to the points.

9.2.7. Quality control of airborne hyperspectral data

Five hyperspectral data sets were acquired in the project: three in 2015 and one each in 2017 and 2019. Each dataset underwent several stages of quality control, the successful completion of which determined the acceptability of the data. Subsequent checks ensured that the products provided met the requirements of the ToR (Terms of Reference) and that corrections were made properly.

First, it was checked whether the data provided covered the entire area of interest. The spatial, spectral and radiometric resolution of the images supplied were checked to ensure that they met the required values. The geometric validity of the data was assessed using photo points measured in the field with a Global Navigation Satellite Systems (GNSS) geodetic receiver. The reference values were compared with the coordinates from the image and the RMSE (Root Mean Square Error) was calculated. The images were also compared visually with higher resolution aerial photographs to detect any anomalies.

The accuracy of the atmospheric correction was assessed by comparing values at selected locations on the image with values from spectrometric measurements in the field. Reference field measurements were made using a Spectral Evolution PSR+ 3600 spectroradiometer. The spectral resolution of the measurements was standardised for comparison. The RMSE was calculated for each point and it was verified whether the value obtained was within the specified error limit. The process of extracting values from the image, resampling and comparison with reference values was automated using the R language.

9.2.8. Quality control of multispectral data

During the project, 14 multispectral datasets were collected. The original plan was to acquire multispectral images from the satellite system. However, due to problems in obtaining data for the study area within the adopted timeframe, related to unfavourable weather conditions, it was decided to replace the satellite data with aerial data from 2017 onwards.

The multispectral satellite images for one acquisition consisted of at least two images. The first stage of quality control was to check whether the images were taken at intervals of no more than two weeks and that they were taken with the correct angle of sensor deviation from the nadir. The next step was to check the cloud cover on the images, which was not allowed to cover more than 5% of the total study area.

The acquired images were subjected to three basic processes: radiometric, atmospheric and geometric correction with orthorectification.

The radiometric correction was carried out by the company responsible for the image processing, Airbus DS. The first on-board correction was performed to correct sensitivity differences between the detectors (internal detector alignment) and to correct for abnormal detectors. Subsequently, the panchromatic band was improved and noise was removed. The final correction step was to resample the pixels (Shannon sampling, see Tan Jiang 2019) to obtain the appropriate pixel resolution (2 m for multispectral and 0.5 m for panchromatic images). At this stage of the processing, the spatial resolution of the provided images was checked.

The atmospheric correction was performed with the code LOWTRAN (Kneizys et al. 1988), which uses modelling of radiative transfer through the atmosphere. This takes into account the physical properties of the atmosphere and the conditions under which the images were taken. Spectral reflectance curves for thirteen different radiometrically fixed objects taken with a Spectral Evolution PSR+ spectrometer during field measurements were used to check the accuracy of the atmospheric correction and spectral resolution.

A geometric correction was performed using Rational Polynomial Coefficient (RPC) points and points measured with a GNSS receiver in the field. The next step was orthorectification, which was performed using a Digital Terrain Model (DTM) with a field pixel size of 2 m, created from airborne laser scanning data acquired in 2015. The accuracy of the geometric correction was verified using measurement points taken in the field. The measurement was performed with a geodetic GNSS RTK (Real Time Kinematic) receiver. In the case of the atmospheric and geometric correction with orthorectification, the mean standard error (MSE) and root mean square error (RMSE) were calculated using the points measured in the field. It was assumed that the RMSE error for the atmospheric correction should be less than 0.5 nm. For geometric correction and orthorectification, the error had to be less than 0.7 pixel.

The first step of quality control of airborne multispectral imaging was to verify that all images taken on a single day were taken at a maximum interval of 7 days and in windless and cloudless weather with a minimum sun elevation above the horizon of 20°. In addition, the lateral and frontal overlap of the images were checked with a minimum of 70 and 80%, respectively, as well as the spatial (0.25 m) and radiometric resolution (at least 12 bits). The

acquired images were subjected to geometric correction based on photo points measured in the field, followed by a bilinear orthorectification process performed with a 1 m resolution Digital Terrain Model derived from airborne laser scanning data acquired in 2015. As with the multispectral satellite imagery, geometric correction and orthorectification were performed based on 34 points measured in the field with a GNSS geodetic receiver, calculating the MSE and RMSE. Correctly processed data had an RMSE value of fewer than 2 pixels (less than 0.5 m).

9.3. Methodology

9.3.1. Dynamics of changes of selected forest stand inventory characteristics on the basis of multi-temporal airborne laser scanning data

Forest stand growing stock

In the applied method for calculating the stand volume for 2015 and 2019, a uniform methodological approach was adopted for both dates. First, based on the ALS data, models for volume (V) were created using the ABA PC method. This method uses statistics calculated for a point cloud from a given sample area. The reference for the point cloud analysis was measurements of stand characteristics using the traditional method. The models developed were based on the following statistics:

- **fe_cbcMe** – third power mean of the Z coordinates of the first reflections (return number = 1),
- **le_p50_var_h** – variance of the height of the last returns (return number = number of returns) located above the half-height determined by the maximum and minimum height of ALS points within the analysed sample plot.

After parameterisation of the models for individual years, the models took the following form:

for 2015:

$$V = 2.839413 * \exp(0.09323122 * fe_{.1m_cbcMe} + 0.01059306 * le_p50_var_h)$$

for 2019:

$$V = 2.778733 * \exp(0.09000275 * fe_{.1m_cbcMe} + 0.01575373 * le_p50_var_h)$$

The evaluation of goodness-of-fit indices of the V_{2015} model on the 2019 data were respectively: $R^2=0.62$, $RMSE=7.83$, $RMSE\%=33.45$, $BIAS=1.62$.

The models were implemented over the entire study area in a 22.36 m × 22.36 m (5 ar) grid for both dates of remote sensing data collection. In this way, the total volume (live

and dead trees) of each 5 ha fragment of the area of the Polish part of the Białowieża Forest was determined using the ABA method. Significant stand dieback occurred in 2015-2019. In order to determine the volume of living trees, the volume of standing dead trees was calculated and subtracted from the total volume of the stand previously determined using the ABA method. For this purpose, the results of the segmentation - detection of individual trees were used. First, the trees measured in the field and visible in the segmentation results were identified. The field measurements provided information on tree species and tree volume. The segments were used to derive tree characteristics based on the CHM: height variables, crown projection areas and crown volume. These variables were used to build models to determine the volume of individual trees by deciduous trees, pines and spruces. The models developed took the form of:

$$V_i = 0.000041 \cdot H_{max}^{2.292069} \cdot area^{0.834182}$$

$$V_{so} = 0.246032 + 0.000176 \cdot (H_{max} \cdot Crown)$$

$$V_{sw} = \left(\frac{H_{max}}{(30.14176 - 0.21965 \cdot H_{max})} \right)^3$$

where:

H_{max} – maximum height of individual tree;

$area$ – tree crown surface area;

$Crown$ – tree crown volume.

The volume model for spruce was developed on a set of 686 trees (Stereńczak et al. 2019), model for pine was developed on a reference set consisting of 156 trees. Volume model for deciduous trees was based on a set of 296 observations (alder - 83, birch - 52, oak - 47, hornbeam - 39, linden - 29, aspen - 20, maple - 14, ash - 12).

Table 9.2. Evaluation indices for the goodness-of-fit of V_{sw} , V_i , V_{so} models on reference data

Index	V_{sw}	V_{so}	V_i
R ²	0.68	0.86	0.78
RMSE	2.0	0.41	0.82
RMSE%	40.00	20.89	49.18
MAE	0.69	0.30	0.53
MAE%	27.6	15.33	32.18
BIAS	0.040	0.027	0.012
BIAS%	1.5	1.37	0.75

The calculated stand volume for the 5 ar grid and the data on the volume of individual dead trees made it possible to determine the volume of living trees and to assign it to individual stands (forest sub-compartments) of the Białowieża Forest. First, the volume sum from the grids intersecting their area was assigned to the forest sub-compartment. For grids whose area did not cover 100% of the area of the forest stand, the percentage of the volume assigned to the grid was taken into account as the percentage share of the grid in the respective sub-compartment. In this way, the volume calculated from the statistics of ALS for the years 2015 and 2019 was assigned to each sub-compartment. This value characterises the total volume in a given grid, i.e. the standing dead and living trees. To remove the volume of dead trees from the total volume of the stand, the dead trees were selected from the layer of individual trees and their volume was subtracted from the sub-compartments where their centroids were located. In this way, the volume of living trees in the sub-compartments was determined.

Forest stand height

Information on individual trees was used to determine the height of the stands. Based on the 2019 segmentation results and the maximum height of a single segment (i.e. tree) obtained from the Canopy Height Model for the 22.36 m × 22.36 m grid, the mean tree height was calculated. These values were averaged over the entire area of the forest sub-compartments. The height determined in this way is actually the height of the upper tree layer and was calculated on the basis of a complete measurement of this feature in the sub-compartment.

9.3.2. Dynamics of changes in the species composition of forest stands based on multitemporal airborne laser scanning data.

Airborne laser scanning datasets were collected three times during the project. Two datasets were collected in 2015 (leaf-on and leaf-off season) and one dataset in 2019 (leaf-on season). For the leaf-on season datasets, the aerial images were acquired in parallel so that spectral reflectance values in the NIR, R and G channels could be assigned to each point in the 3D ALS point cloud. Individual trees were extracted based on the method described by Stereńczak et al. (2020a). Based on data from 2015 and 2019, individual trees were classified into the following species: spruce, pine, deciduous, and divided into 'live' and 'dead' classes, using the methodology developed by Kamińska et al. (2018). This made it possible to estimate the number of individual tree species in the upper layers of the stands and to determine their health status, as well as to analyse changes in species structure over the duration of the project.

9.3.3. Dynamics of changes in vertical structure and canopy closurew

Vertical structure analysis

Modelling of the vertical structure of forest stands was based on data from 482 (5 ar) sample plots located in the Polish part of Białowieża Forest, where inventory surveys

were made in 2015. Statistics were calculated for these plots from ALS data from the same year.

To build the model, logistic regression was used in the form:

$$P(Y = 1|x_i) = \frac{e^{a_0 + \sum_{i=1}^k a_i x_i}}{1 + e^{a_0 + \sum_{i=1}^k a_i x_i}}; i = 1 \dots k$$

where:

Y – a dichotomous variable with values: 1- multilayer structure, 0- single-layer structure;

a_i – regression coefficient;

x_i – height percentiles from ALS data for the sample plots;

k – number of plots analyzed.

The maximum likelihood method was used to estimate the parameters of the model. The model was built using a hierarchical method. 70% of the study plots (337 sample plots) were used to build the model, while the remaining 30% (145 plots) were used to validate it. The search for the best subset of explanatory variables resulted in an optimal model of the form:

$$P(Y = 1|x_i) = \frac{e^{-2.2047+0.2181P_{15}-0.0762P_{55}+0.0939P_{95}}}{1+e^{-2.2047+0.2181P_{15}-0.0762P_{55}+0.0939P_{95}}};$$

where:

P_{15} – 15th percentile for height;

P_{55} – 55th percentile for height;

P_{95} – 95 percentile for height.

The optimal model accurately identified 72.6% of cases where a single-layer structure was present, and 66.86% of cases where a multi-layer structure was present. The overall classification accuracy on the training set was OA=70% and on the validation set OA=63.95%.

Canopy closure analysis

The analysis of the horizontal structure should be understood in this case as the analysis of the canopy closure of the first floor of the stands of the Białowieża Forest in 2015. The canopy closure of the forest in the sub-compartments was calculated using a layer of individual trees determined by the segmentation method (Sterenczak et al. 2020a) and a layer of gaps,

the detection and definition of which is described below. Gaps larger than 2 ares were used for crown closure analysis in accordance with the 2012 Forest Management Plan (FMP). The canopy closure analysis was carried out for each of the forest sub-compartments and consisted of the following steps:

- selection of individual trees (segments) whose centroid is located inside the sub-compartments and whose height is greater than 7 m;
- selection of the part of the gap layer that overlaps with the sub-compartment;
- counting of the areas of the crown projections of trees within the bounds of the sub-compartments and the areas of gaps within the sub-compartment;
- calculation of the canopy closure coefficient from the formula:

$$\text{canopy closure ratio} = \frac{\text{crown projection area}}{\text{sub-compartment area} - \text{gap area}}$$

The steps described are repeated for each of the sub-compartment.

The stand canopy closure was determined for all trees in the sub-compartments, with the exception of dead trees. The calculated values of the canopy closure ratio, taking values from 0 to 100%, were divided into five categories, resulting from the level of canopy cover:

- < 30% – none closure,
- 30–45% – open canopy closure,
- 46–65% – broken canopy closure,
- 66–85% – moderate canopy closure,
- > 85% – full canopy closure.

After applying above mentioned methodology for both analysis periods, the canopy closure in the forest sub-compartments for 2015 and 2019 were obtained. Canopy cover was analysed for 16,057 sub-compartments representing only areas with stands in Białowieża Forest.

9.3.4. Gap dynamic

ALS data from 2015 and 2019 were used to analyse gap dynamics. These data were used to create gap maps for both time periods and compare the changes in both areas and within gaps that occurred over the 4 years. For the purposes of the analyses, the following definition

of a gap was adopted: an open area in a stand with a vegetation of height lower than 2 m and an area of more than 20 m². Gaps occurring in the Białowieża Forest were divided according to their area into small (≤ 5 ar), medium (5-30 ar), large (30-50 ar) and very large (> 50 ar) gaps.

Gap detection was carried out for the entire Polish part of the Białowieża Forest. The processing was done in the same way for the 2015 and 2019 airborne laser scanning data using the Canopy Height Model, which is the difference between the Digital Surface Model (DSM) and the Digital Terrain Model (DTM). Based on the identified heights of potential gap areas, it was possible to develop a raster mask for gaps in which pixels with a value of 1 represented locations where the vegetation relative height was less than 2 m. Regions above this height were given a value of 0 in the mask. Since it was not possible to process the entire model CHM at the same time, a special algorithm had to be developed to generate a gap mask from such a large data set. The generation of the gap mask was carried out in regions defined by an experienced operator who identified dense forest complexes separated by roads or major watercourses. A mask of gap areas was generated for each region. Gaps, which were represented as individual pixels and represent potential errors in processing airborne laser scanning data into an elevation grid, were removed from the masks. Each region was then polygonised, i.e. the raster was converted to vector polygons. The polygons from each region were merged into a single layer. The resulting layer was then filtered by removing single objects of less than 1 m². In the final stage of processing, the polygons were intersected with the layer of forest sub-compartments in the Białowieża Forest. Gaps touching the boundary of the aggregate area were removed from the trimmed layer, as they were potentially part of a larger gapless open space. After the automatic selection process, an additional visual inspection of all polygons obtained was carried out based on high-resolution aerial photographs to exclude processing errors.

To analyse changes in the number and size of gaps, vector layers with gaps from two points in time, 2015 and 2019, were required. The layers are stored as tables in a PostGIS database, so all calculations regarding the number of gaps in the database were based on SQL queries. Since layers with annotated attributes for the gap area were available, the total gap area and its change in 2019 were calculated in the same way.

9.4. Results

9.4.1. Dynamics of changes of selected forest stand inventory characteristics on the basis of multi-temporal airborne laser scanning data

Forest growing stock and volume

The results of determining the growing stock of forest stands in the Białowieża National Park (BNP) for dead and live trees in 2015 and 2019 show minor differences in the volume dynamics of standing live and dead trees (Fig. 9.1, 9.2 and 9.3). In contrast, in the areas outside the Białowieża National Park, the volume of living trees decreased on average by 35 m³ ha⁻¹, and dead trees increased by 29 m³ ha⁻¹ (Fig. 9.1 and 9.2). The greatest change in the growing stock of living trees was recorded for the areas located in Białowieża Forest District - a decline of 38.2 m³ ha⁻¹. The largest change in the standing volume of standing dead trees was recorded in the stands in the Hajnówka Forest District - it was an increase of 31.9 m³ ha⁻¹ (Tab. 9.3 and 9.4).

Table 9.3. The average growing stock of forest stands in 2015 and 2019 in individual administrative districts of the Polish part of Białowieża Forest

Administrative District	2015		2019	
	Growing stock of living trees [m ³ ha ⁻¹]	Growing stock of dead trees [m ³ ha ⁻¹]	Growing stock of living trees [m ³ ha ⁻¹]	Growing stock of dead trees [m ³ ha ⁻¹]
Białowieża National Park	412.6	18.7	414.3	18.9
Browsk Forest District	400.7	12.5	368.9	43.5
Hajnówka Forest District	406.1	11.9	370.0	43.8
Białowieża Forest District	405.3	25.2	367.1	50.1

During the study period, i.e. between 2015 and 2019 in the entire Polish part of the Białowieża Forest, the total volume of living trees calculated on the basis of remote sensing data decreased by 8.5% (2.09 million m³), while the volume of standing dead trees increased by 147.7%. The decrease in the volume of living trees was the same in all forest districts and amounted to about 10%, while in the Białowieża National Park it occurred only to a small extent and amounted to almost 3 thousand m³. In terms of the number of dead trees, the increase was highest in the Browsk and Hajnówka forest districts, while this value decreased by 2% in the Białowieża National Park.

Table 9.4. The growing stock of forest stands in 2015 and 2019 in individual organisational districts of the Polish part of Białowieża Forest

Administrative District	2015		2019	
	Growing stock [m ³]	Stock of dead standing trees [m ³]	Growing stock [m ³]	Stock of dead standing trees [m ³]
Białowieża National Park	4,228,138	198,352	4,225,313	194,820
Browsk Forest District	7,279,477	246,727	6,528,579	887,947
Hajnówka Forest District	7,809,234	251,295	7,014,110	898,789
Białowieża Forest District	5,108,576	383,521	4,571,349	682,983
TOTAL	24,452,426	1,079,895	22,339,351	2,664,539

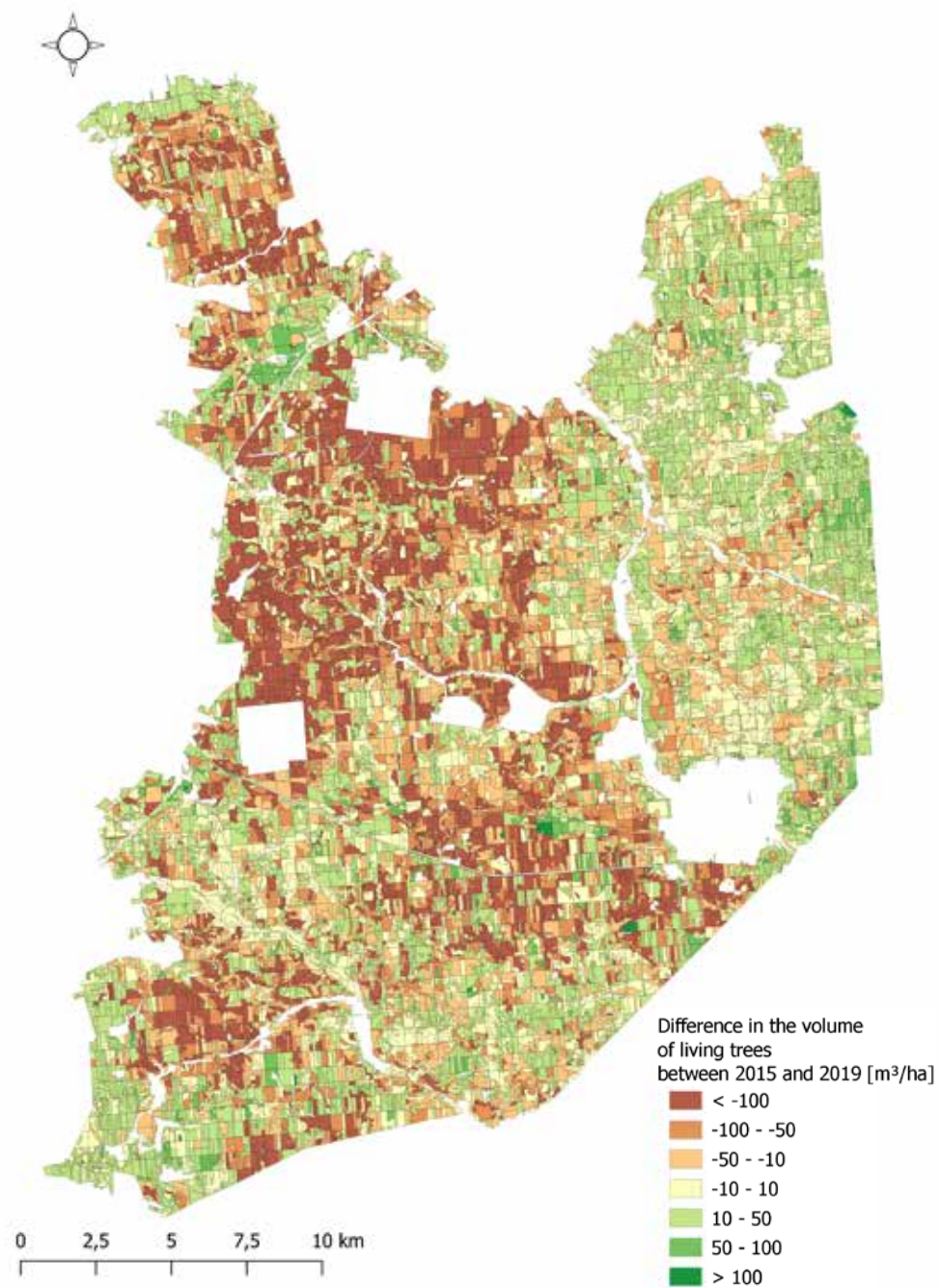

Figure 9.1. The difference in the volume of living trees in sub-compartments of BF between 2015 and 2019

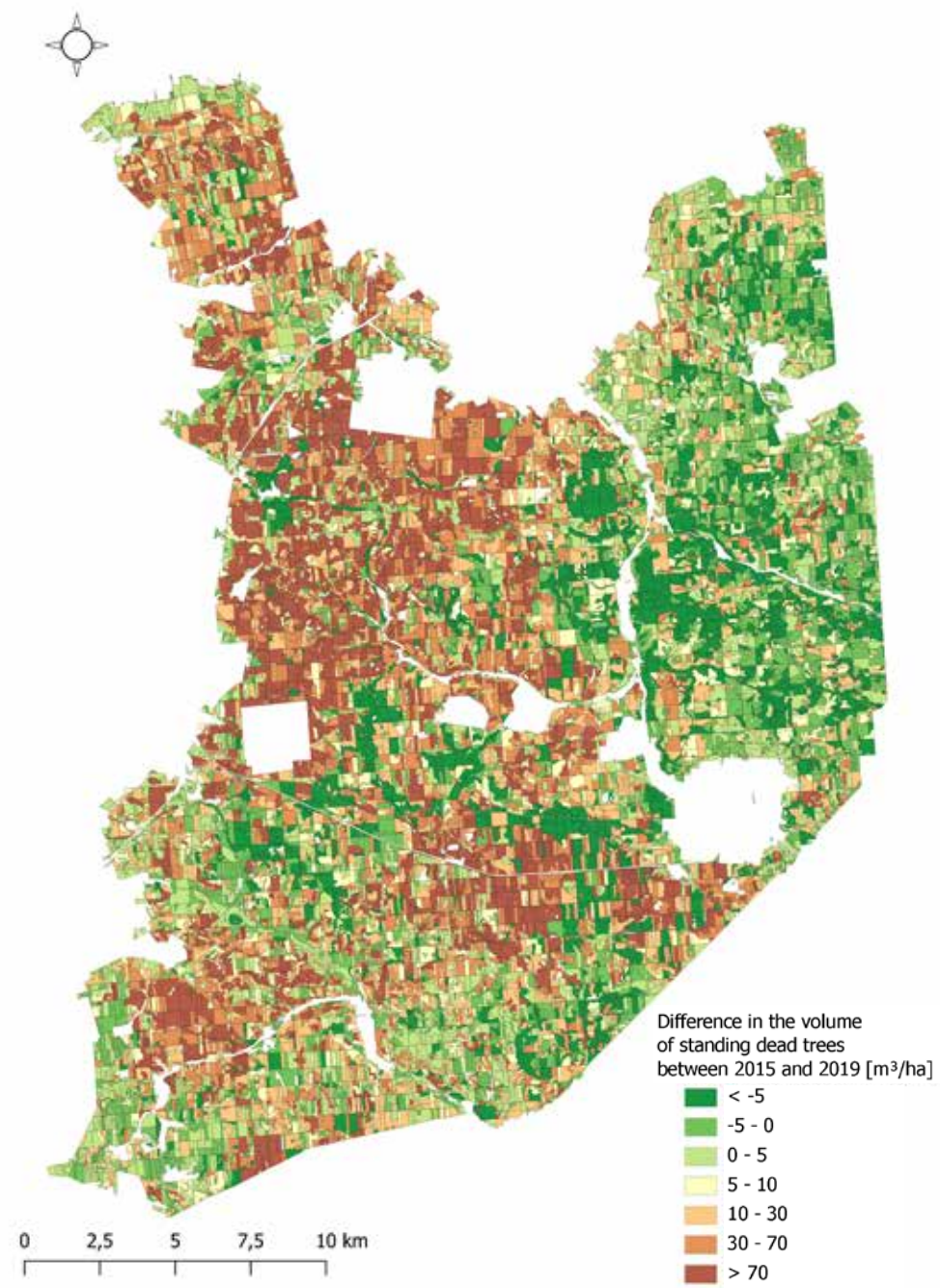

Figure 9.2. The difference in the volume of standing dead trees in the sub-compartments of BF between 2015 and 2019

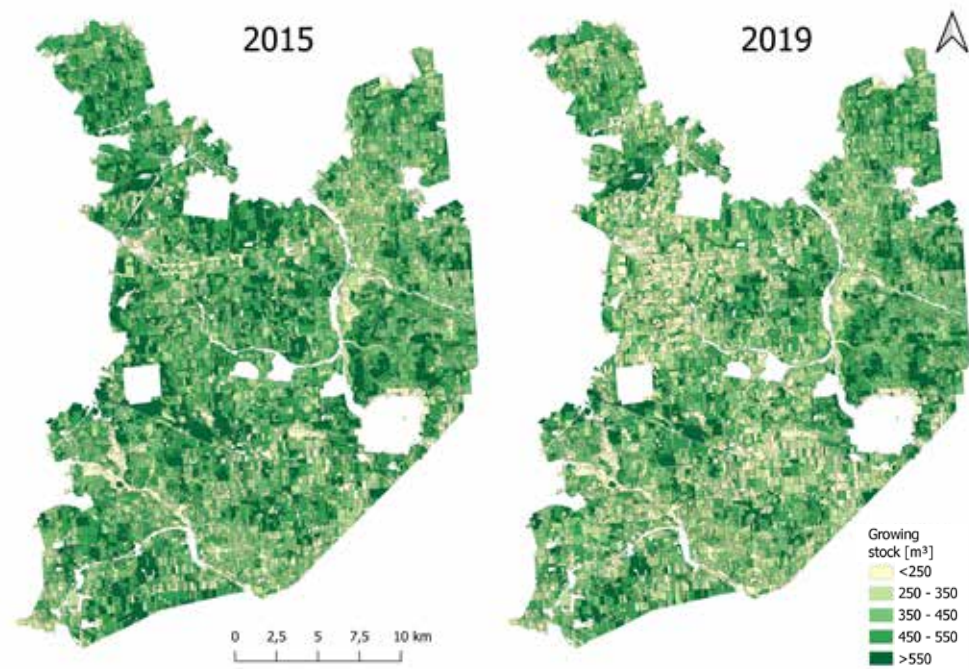

Figure 9.3. The growing stock of living trees in the forest sub-compartments of the Polish part of Białowieża Forest in 2015 and 2019

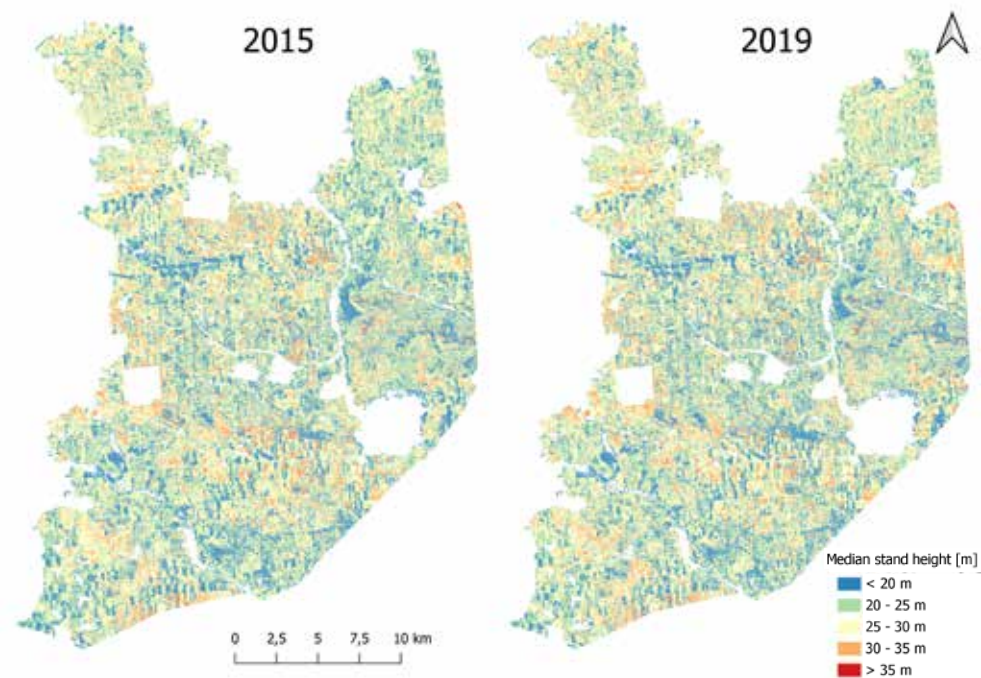

Figure 9.4. Median stand height in the 5 ar grid (pixels) in 2015 and 2019

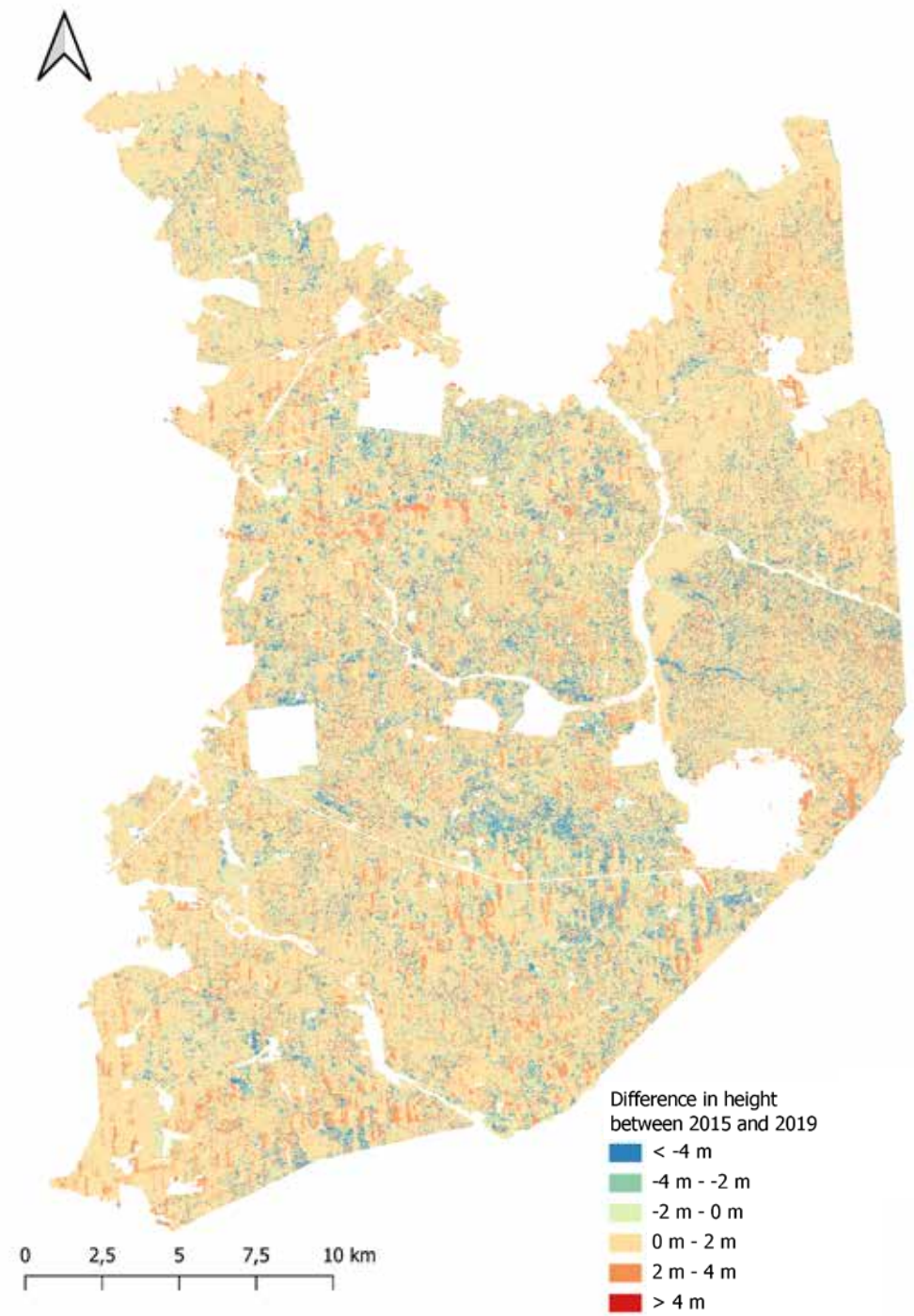

Figure 9.5. Difference in median stand height in 5 ar grids (pixels) between 2015 and 2019

Forest stand height

By compiling the area of BF, where the median stand height changed, the following values were determined:

- 3,544 ha with a difference of less than -4 m (6.2% of the area),
- 2,490 ha with a difference of -4 m to -2 m (4.4% of the area),
- 9,520 ha with a difference of -2 m to 0 m (16.8% of the area),
- 34,130 ha with a difference of 0 m to 2 m (60.1% of the area),
- 5,979 ha with a difference of 2 m to 4 m (10.5% of the area),
- 1,093 ha with a difference of more than 4 m (1.9% of the area).

When analysing the change in the median, it can be seen that the value increased on average in all forest districts except for the Białowieża Forest District, which is probably mainly related to the intensive bark beetle outbreak and harvesting in this forest district.

9.4.2. Dynamics of changes in species composition based on multitemporal airborne laser scanning data

In 2015, in the Polish part of the Białowieża Forest, deciduous trees accounted for the largest proportion of living trees (59.6%), followed by spruce (21.0%) and pine (15.8%). Among the dead trees, the largest proportion was deciduous trees (1.9%), spruces (1.3%) and pines (0.4%) (Fig. 9.6). The highest proportion of deciduous trees, both living and dead, was found in Białowieża National Park, where it amounted to 68.2% and 2.6% of all trees, respectively. The highest proportion of live spruces was in the Hajnówka Forest District (23.3%) and of pines in the Browsk Forest District (18.5%). Among the dead conifers, the highest proportion of dead spruce was recorded in the Białowieża Forest District (2.5%) and of dead pine in the Białowieża National Park (0.5%).

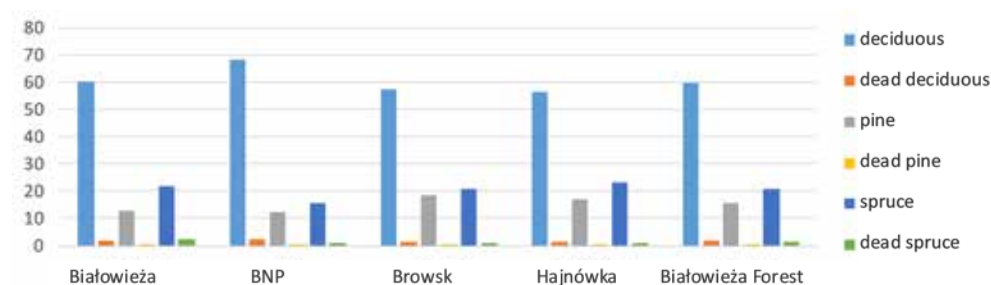

Figure 9.6. The percentage share of the individual tree species in the Polish part of the Białowieża Forest was determined on the basis of the area of crown projections on a horizontal plane in 2015

The changes in the structure of the stands of the Białowieża Forest, mainly related to the spread of the bark beetle outbreak as well as with commercial and protection activities, are directly reflected in the proportion of individual tree species. In the Białowieża Forest in 2019, data determined on the basis of the crown area showed that 61.7% of the total number of all standing live and dead trees was occupied by deciduous trees, 16% by pines and 13.7% by spruces. Among the dead trees, spruce had the highest proportion (6.2%), followed by deciduous trees (1.9%) and pines (0.5%) (Fig. 9.7). The highest proportion of living deciduous trees was in the Białowieża National Park with a share of 67.4%. The highest proportion of live pines was found in the Browsk Forest District (19.1%) while live spruces were found in the Białowieża National Park (16%). As for dead trees, the highest proportion of dead spruce was recorded in the Browsk Forest District (7.3%), while dead deciduous trees and dead pines were found in the Białowieża Forest District (2.5% and 0.6%, respectively).

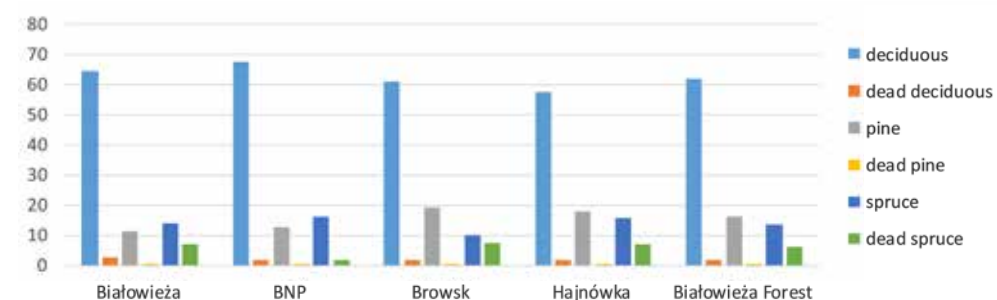

Figure 9.7. Percentage share of individual tree species in the Polish part of the Białowieża Forest determined from the area of crown projections on a horizontal plane in 2019

The results for the 2015 and 2019 classifications clearly show a continuing trend towards the death of spruce stands in the Białowieża Forest during this period, which also has a direct impact on changes in the stand structure of other forest-forming species in the area. In all forest districts, a trend towards a significant decrease in the proportion of spruce was observed, with a simultaneous increase in the proportion of dead spruce. In the forest districts, this also led to an increase in the share of deciduous tree species, which previously mostly occupied the 2nd floor of the stand. Interestingly, in the Białowieża National Park, changes of no more than 1% were observed in the individual tree species, both living and dead (Fig. 9.8 and 9.9).

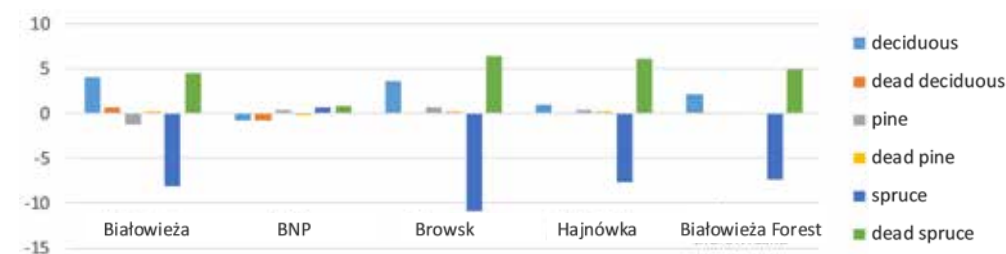

Figure 9.8. Percentage difference in the proportion of individual tree species in the Polish part of Białowieża Forest determined on the basis of the area of crown projections on a horizontal plane between 2015 and 2019

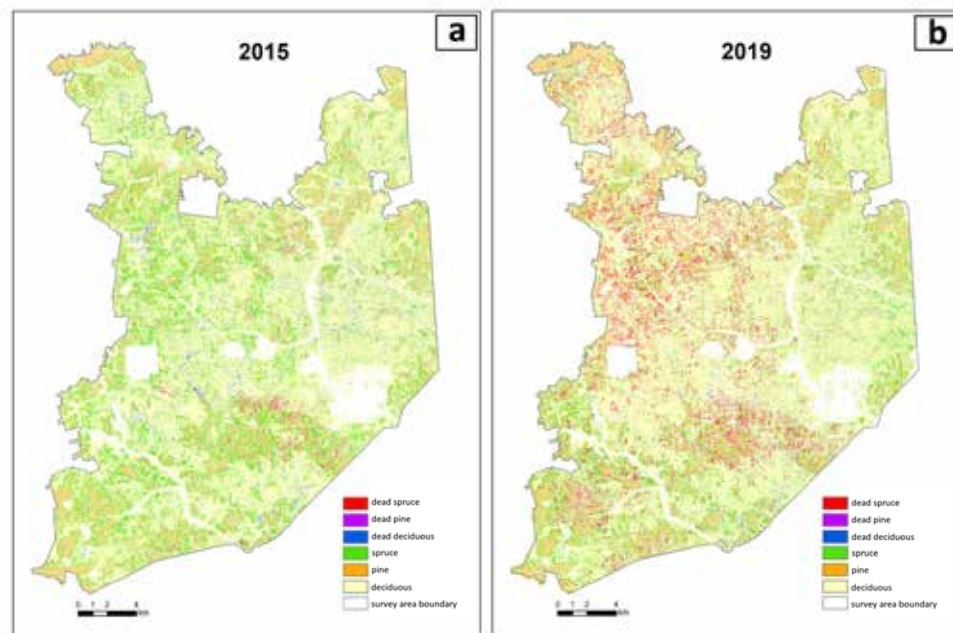

Figure 9.9. Species classification based on ALS data in 2015 (a) and 2019 (b)

Table 9.5. Area of stand fragments with single- and multi-layer structure in the Polish part of the Białowieża Forest in 2015 and 2019

Administrative District	Area occupied by a particular stand structure [ha]			
	Single-layer		Multi-layer	
	2015	2019	2015	2019
Białowieża Forest District	6,173	7,079	5,978	5,072
Browsk Forest District	10,061	10,818	6,800	6,042
Hajnówka Forest District	10,465	11,351	7,867	6,981
Białowieża National Park	5,256	5,696	4,678	4,237
TOTAL	31,955	34,944	25,323	22,332

9.4.3. Dynamics of changes in the vertical structure and canopy closure in forest stands

Vertical forest stand structure analysis

Over the course of four years, the vertical structure of the stands of the Polish part of the Białowieża Forest has been simplified. Between 2015 and 2019, the proportion of stands with a single-layer structure increased compared to multi-layer stands (Tab. 9.5). This was often associated with the death of spruce in the upper layer of the stand, which led to a simplification of the stand structure and the replacement of the multi- or two-layer structure with a single-layer structure. The largest changes in terms of the area were observed in the Białowieża Forest District (906 ha), where the intensity of bark beetle infestation was the highest in the studied period. The lowest changes in terms of the area were recorded in the Białowieża National Park (440 ha), where the mentioned bark beetle outbreak had the lowest dynamics. The vertical structure of tree stands changed on 5% of the area of the Polish part of the Białowieża Forest (Tab. 9.5 and Fig. 9.10 and 9.11).

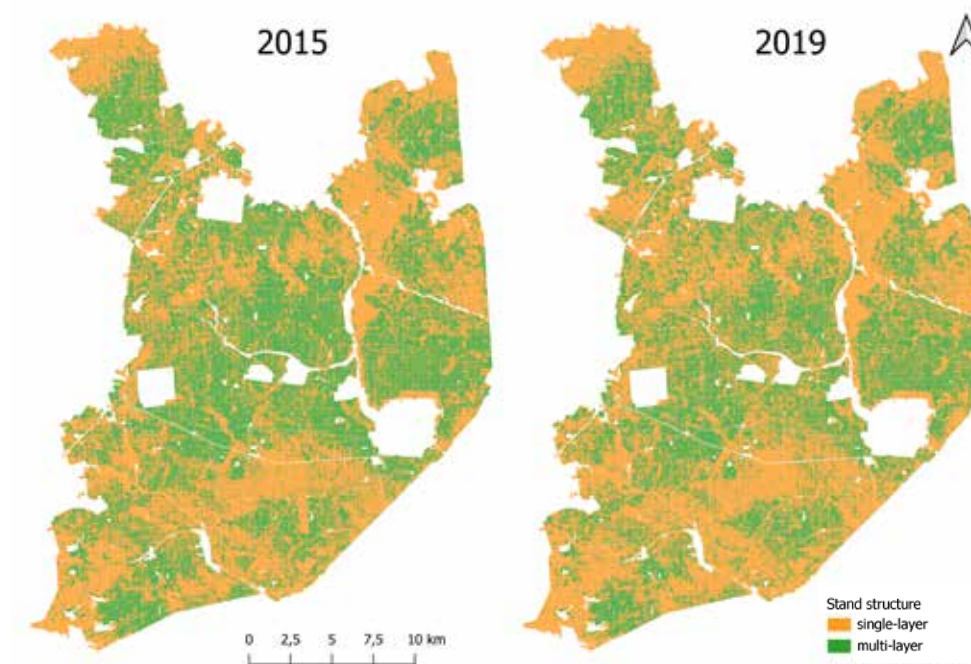

Figure 9.10. Spatial distribution of stand fragments with different vertical structure in the Polish part of the Białowieża Forest in 2015 and 2019

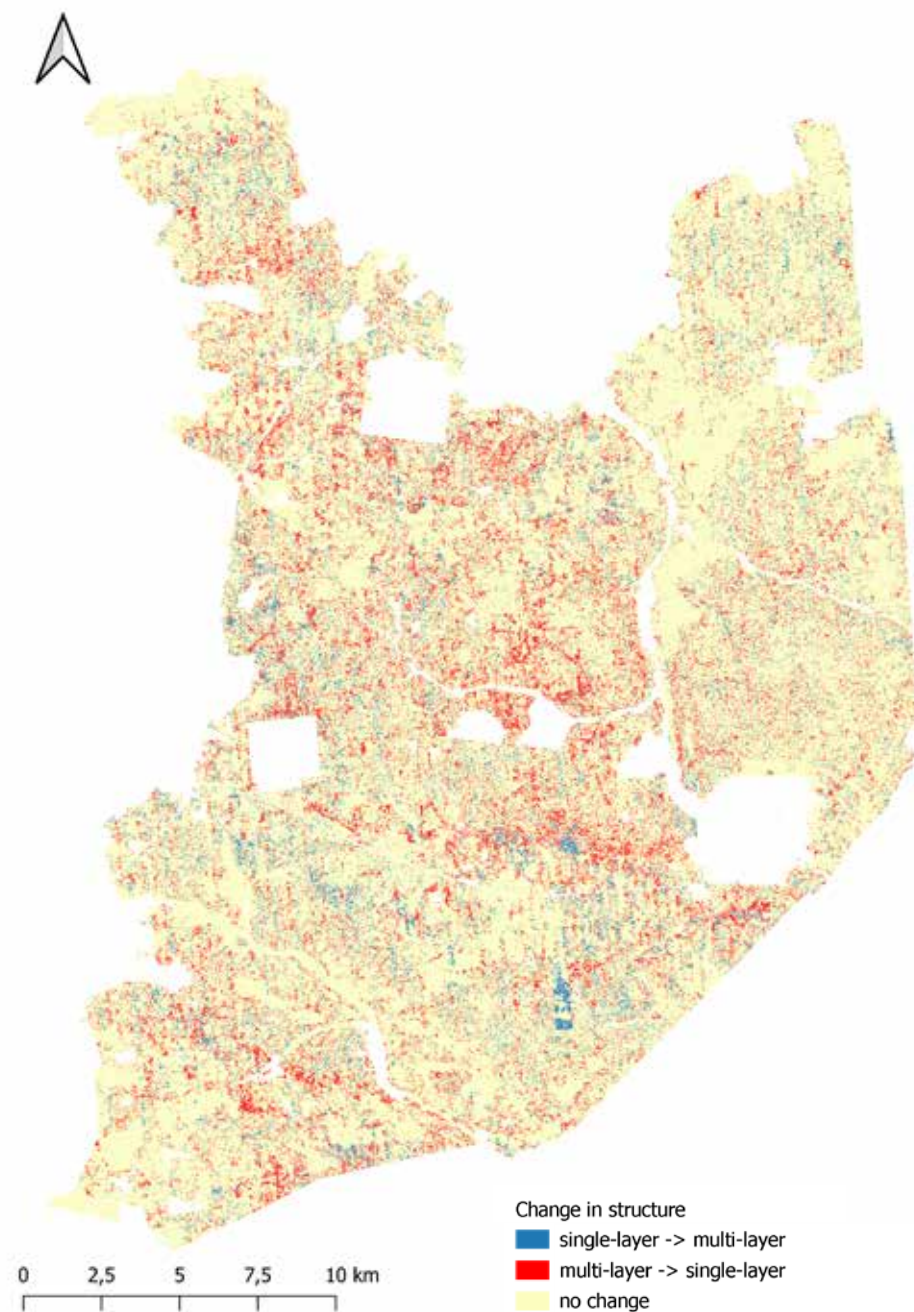

Figure 9.11. Spatial distribution of changes in the vertical structure of forest stand fragments in the Polish part of the Białowieża Forest in the period 2015-2019

Stand canopy closure analysis

Canopy closure was analysed for 16,057 sub-compartments containing only stands of the Białowieża Forest (excluding open areas). The changes in canopy closure in the period 2015–2019 are mainly due to the bark beetle outbreak (Tab. 9.6 and Fig. 9.12). This caused the death of a large part of the spruce population which dominated the stand structure due to its age and usually formed the first layer of the stand.

Table 9.6. The number of sub-compartments with a given canopy closure ratio in the Polish part of the Białowieża Forest excluding areas with dead trees in 2015 and 2019

Administrative District	full canopy closure		moderate canopy closure		broken canopy closure		open canopy closure		none	
	2015	2019	2015	2019	2015	2019	2015	2019	2015	2019
Białowieża Forest District	1,287	956	1,798	1,472	232	586	42	274	24	95
Browsk Forest District	1,999	1,579	2,172	1,788	130	676	20	207	16	87
Hajnówka Forest District	2,574	1,985	2,748	2,200	184	883	26	298	10	176
Białowieża National Park	692	771	1,843	1,556	311	401	5	55	4	72
TOTAL	6,552	5,291	8,561	7,016	857	2,546	93	834	54	430

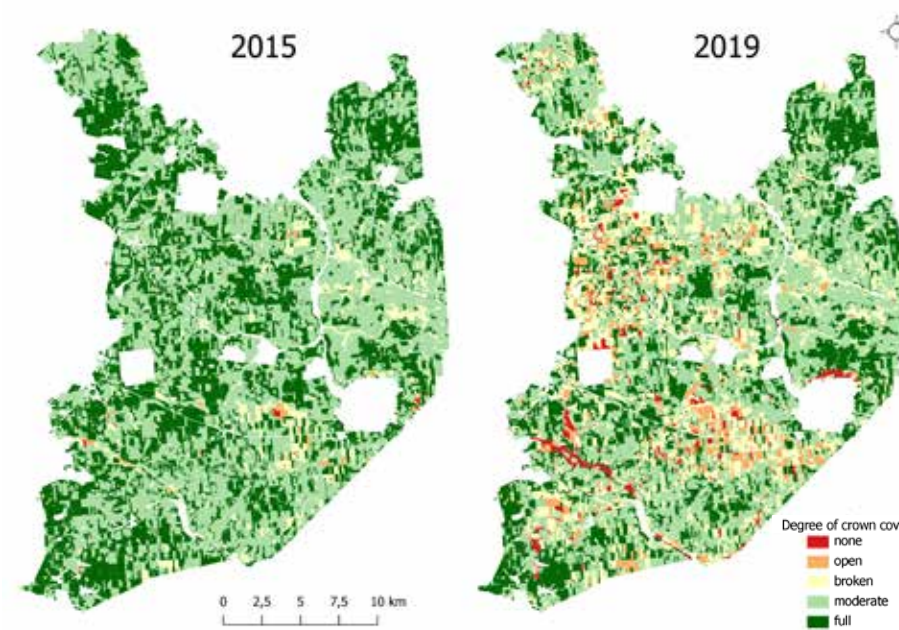

Figure 9.12. Spatial distribution of the canopy closure ratio of stands of the Polish part of Białowieża Forest excluding dead trees in individual segments in 2015 and 2019

When analysing the change in the ratio of crown closure during the period 2015-2019 (Tab. 9.7), it can be seen that the largest number of sub-compartments (1,737) changed from moderate to broken canopy closure. There were similarly numerous changes in the case of full canopy closure: in 1,613 sub-compartments it changed to moderate canopy closure, which was undoubtedly an effect of the dynamically developing bark beetle outbreak at that time.

Table 9.7. Summary of the change in the degree of canopy closure in sub-compartments in the Polish part of the Białowieża Forest excluding the areas covered with dead trees between 2015 and 2019

		The level of canopy cover in 2019				
		None	Open	Broken	Moderate	Full
The level of canopy closure in 2015.	None	21	14	6	12	1
	Open	33	30	18	11	1
	Broken	92	164	454	144	4
	Moderate	250	552	1,737	5,237	785
	Full	39	74	332	1,613	4,500

9.4.4. Gap dynamics

Gaps in forest stands can appear, overgrow or expand, individual adjacent gaps can also merge into one, and a large gap can divide into two or more. To analyse the changes between and within individual gaps, it is necessary to recognise these relationships (Fig. 9.13).

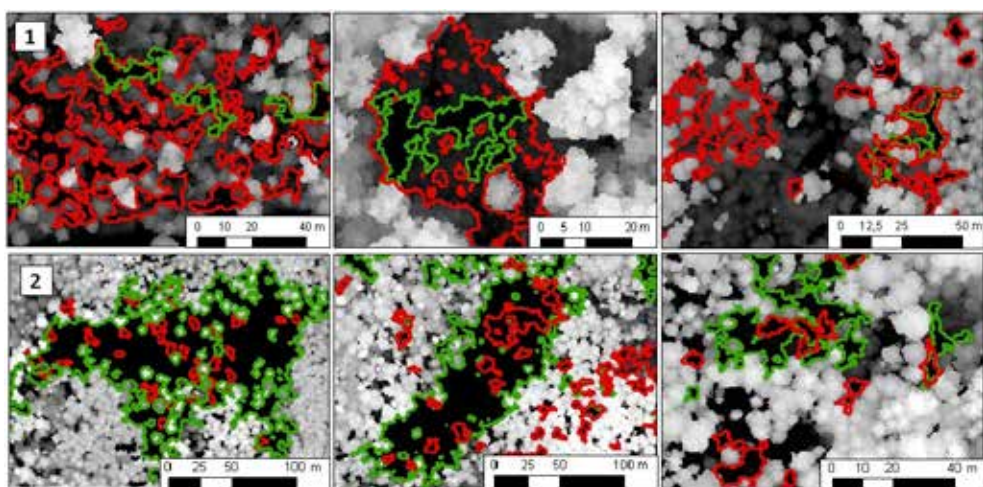

Figure 9.13. Gap dynamics - examples of gaps overgrowing (1) and expanding (2). Red colour - 2015, green colour - 2019, base layer - DTM 2019

In the area of the Polish part of Białowieża Forest, 254,016 gaps with a total area of 2189.4 ha were detected in 2015, while in 2019 - 252,006 gaps with a total area of 2601.7 ha (Tab. 9.8).

Table 9.8. Total area and a number of gaps generated in a given year and their dynamics in the period 2015–2019 in the Polish part of Białowieża Forest (PB)

Date	Number of gaps	Total area of gaps [ha]	Average area of gaps [ha]	Min. Area of gaps [ha]	Max. Area of gaps [ha]	% coverage of BF by gaps
2015	254016	2189.4	0.0086	0.0020	4.6045	3.87
2019	252006	2601.7	0.0103	0.0020	9.3946	4.60
change	-2010	+412.3	+0.0017	-	+4.7901	+0.73

During 2015-2019, the total number of gaps decreased by 2,010, while the total area of gaps increased by 412.3 ha. The area of individual gaps increased by a maximum of 4.7901 ha, while the average area of individual gaps increased by 0.0017 ha. The percentage share of gaps in the area of the Polish part of the Białowieża Forest also increased - by 0.73 percentage points. In 2019, the area of gaps in spruce stands increased by more than 12 percentage points compared to 2015 (Tab. 9.9).

Table 9.9. Proportion of species in gaps and their dynamics in 2015-2019 in the Polish part of the Białowieża Forest

Species	Percentage in the total gaps area		Difference
	2015	2019	
other	5.91	6.37	0.46
birch	3.1	3.33	0.22
oak	5.74	5.3	-0.44
hornbeam	6.73	4.81	-1.92
lime	8.81	5.86	-2.95
alder	18.55	11.8	-6.74
pine	22.92	21.96	-0.96
spruce	28.24	40.58	12.34

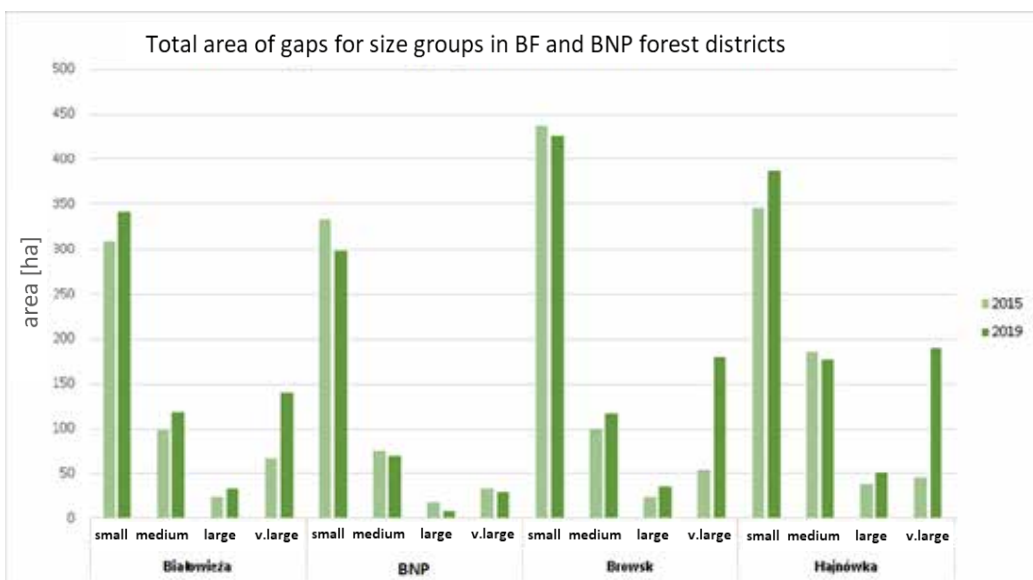

Figure 9.14. Changes in the total area of gaps for size groups in the forest districts of the Polish part of the Białowieża Forest (BF) and the Białowieża National Park (BNP) in the period 2015–2019

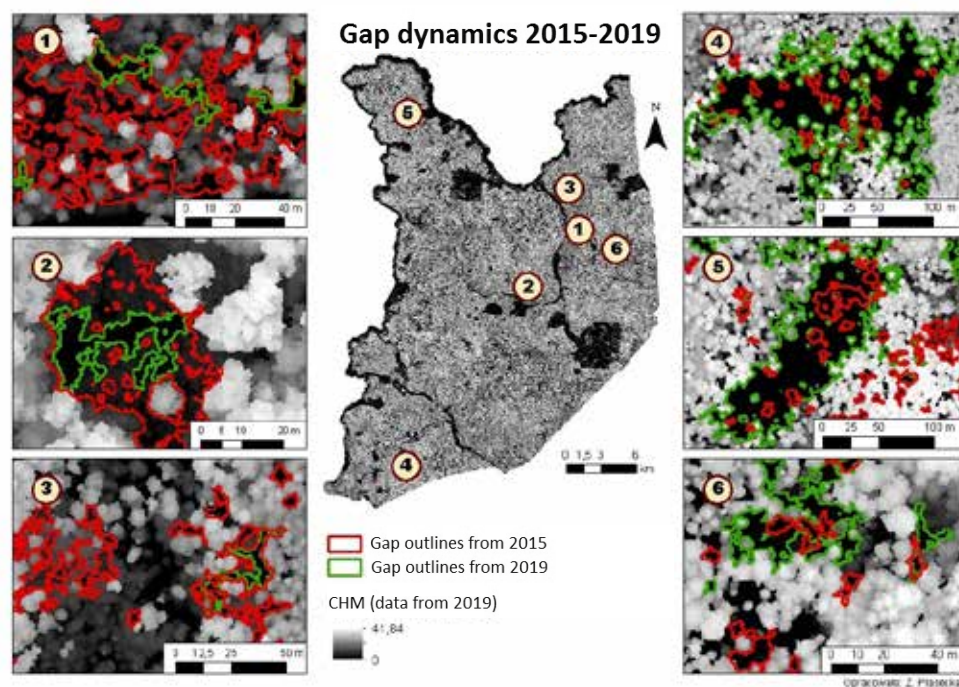

Figure 9.15. Dynamics of selected gaps in the Polish part of Białowieża Forest in 2015–2019

In three forest divisions of the Polish part of the Białowieża Forest, an increase in the total area of gaps was observed: in the Białowieża Forest District - by 136.3 ha, in the Białobok Forest District - by 141.1 ha, in the Hajnówka Forest District - by 188.4 ha. In the Białowieża National Park, a decrease in the total area of gaps by 53.5 ha was recorded. Changes in the area of gaps can also be seen in the different size groups (Fig. 9.14 and 9.15).

9.5. Discussion

The results presented in this chapter are only a part of the remote sensing analyses conducted within the project and published in previous papers (e.g. Erfaniferad et al, 2018, 2019; Kamińska et al, 2018, 2020, 2021; Kraszewski et al, 2020; Laurin et al. 2020; Mielcarek et al. 2018, 2020; Modzelewska et al. 2020, 2021; Olpenda et al. 2019; Stereńczak et al. 2017, 2019, 2020a, 2020b). In many cases, the data processing and analysis methodologies presented in this chapter have been described in detail in scientific papers, hence the frequent references to specific publications.

In the LIFE+ ForBioSensing project, different remote sensing data sets were used. Airborne laser scanning data were used - thanks to their attributes - to reconstruct the ground surface by converting a point cloud into a Digital Terrain Model and the surface reflecting the objects on the ground surface by converting a point cloud into a Digital Surface Model. By subtracting the values of the corresponding pixels in the DSM and DTM, a model representing all objects on the surface with their relative height was obtained - a normalized DSM; and for forest areas - the Canopy Height Model. The CHM was used in many analyses carried out for the purpose of monitoring the Polish part of the Białowieża Forest. In particular, it was used in the process of detecting individual trees. Individual tree crowns identified in 2015, the first year in which remote sensing data were collected, formed the basis for most of the work related to the analysis of changes in the stands of the Białowieża Forest. In particular, the results of the segmentation of CHM together with the results of classification of digital aerial or satellite images supported the temporal and spatial analysis of the spread of bark beetle outbreak in the Białowieża Forest, reflected in the number of standing trees inventoried. In addition, remote sensing data were used to determine the volume of standing dead trees, the dynamics of changes in growing stock, and to identify trees in the Białowieża Forest that are dangerous from a tourism perspective (Stereńczak et al. 2017), as well as to analyse the vertical and horizontal structure of the forest stands. These analyses, carried out for such a large forest area in terms of individual trees and multitemporal data, are unique. The developed methods of using remote sensing data are of great importance from the cognitive point of view and allow implementation of the obtained results in practice.

An essential element of remote sensing analysis is the proper collection and quality control of the data provided. Data quality control should be an integral part of all analyses. Special attention must be paid not only to the correctness of the input data but also to the quality and correctness of the products generated throughout the process. Each stage of quality control should prevent the operator from receiving undesirable results due to incorrect data. The probability of errors occurring increases with the complexity of the analytical process, which may consist of many steps and integrate information from many different data sets.

Quality control should focus first on the input data and then on the individual sub-products of the production process. The final confirmation of the correctness of the entire data analysis process is the evaluation of the final product, which verifies its compliance with expectations and determines its quality. Automating the process of quality control (Kraszewski et al. 2020) and subsequent elements of the analyses saves time and at the same time enables the review of entire data sets submitted after any corrections.

The data used in this chapter was a large set of digital information, which is a specific example of the collection of so-called Big Data. It was a large volume of data of several terabytes that required an innovative approach to its processing and included data of different types: 2D and 3D remote sensing and numerical data. The integration of these data and their mutual analysis has led to new information that cannot be achieved by analysing individual data sets. For example, the airborne laser scanning data collected in 2015 and 2019 alone took up 403 GB, to which must be added the spectral data and as-built survey data collected in 2015, 2017 and 2019 (over 150,000 records). At the beginning of the project - in 2014 - there were not many cloud-based tools and solutions currently available, so getting a handle on proper data storage and processing was a challenge.

Modelling of the volume of the Białowieża Forest stands was carried out using the well-known and proven method ABA PC (Næsset 2002; Parkitna et al. 2021). The values obtained are in agreement with the results of the ground-based analyses (Chapter 4). The prediction accuracy determined in the sample plots took good values, mainly due to the edge effect, which has also been confirmed in other studies in the region (Laurin et al. 2020). The edge effect occurs when the crowns of trees that were not measured in the field (because their trunks were not within the monitoring plot) penetrate the surface and therefore leave a trace in the data from ALS. As a result, the variables used in the modelling of the volume in the sample plot are distorted because ALS points that were just reflected from the crowns of the trees not measured in the sample plot are included in their calculation. This effect is exacerbated when test plots with a relatively small area in relation to tree size are used, especially in stands with diverse structure. In the stands of the Białowieża Forest, we are dealing with both situations. Nevertheless, the obtained results agree very well with the results of the field-based measurements, so we can conclude that the applied method provides accurate and reliable information about the volume and growing stock of the Białowieża Forest. It should be noted that the information on the volume of dead trees was included in the analysis on the basis of the ITD (Individual Tree Detection) method. This approach is not often found in the literature and allowed us to provide comprehensive and locally precise information on the dynamics of Białowieża Forest stands.

The height of the stands was determined in the most accurate way, as the measurement of the height of all trees was used, which was determined with a single tree detection algorithm (Stereńczak et al. 2020a, 2020b). This type of measurement is accurate and is often used with ALS data to determine the characteristics of individual trees (Mielcarek et al. 2018). The presented method for determining stand heights differs from the standard inventory method as it uses information from all trees and not only sampled ones. On the one hand, this has advantages as the height is determined more accurately, but the disadvantage of this method is that it is difficult to compare it with the height determined for the sub-compartment

by means of a methodology adopted in forest management practices. Thanks to the unified methodology, it was possible to carry out an accurate analysis of changes in the height of forest stands in the entire Polish part of the Białowieża Forest. The changes recorded were related to the height growth of trees, but also to changes in the structure of forest stands in the area, mainly due to bark beetle outbreak, which reached unprecedented levels in the period studied (Grodzki 2016).

The analysis of the species structure, or more precisely the proportion of pine, spruce and broadleaf tree species together, primarily served to illustrate and quantify the far-reaching changes caused by the bark beetle infestation. The proportion of spruce in the upper layer of the stand decreased by about 40% between 2015 and 2019. Such a dynamic change indicates intensive thinning as a result of the bark beetle infestation. Thanks to the possibility of monitoring the condition of individual trees (Kamińska et al. 2018), it was possible to determine the dynamics and spatial extent of the bark beetle outbreak spread in 2015 (Stereńczak et al. 2019) and in 2015-2019 (Kamińska et al. 2021), as well as to identify the factors determining the progress of the bark beetle outbreak (Kamińska et al. 2020, 2021; Stereńczak et al. 2020b).

The analysis of the dynamics of the forest stand structure confirmed the previous results, i.e. it revealed the fragments of the Polish part of the Białowieża Forest where the greatest changes occurred as a result of bark beetle infestation, economic activities and protection measures, as well as other processes and phenomena (e.g. strong winds). The proposed methodological solutions made it possible to analyse the changes in the period 2015-2019 in a consistent and objective way, which was previously not possible for the entire study area using ground-based data. An important observation was the fact of a strong separation of the first layer of the forest, but also an indication that in many stands of the Białowieża Forest there was a second layer exposed by the outbreak. This was particularly visible in the vertical structure, which was simplified in many places (about 3,000 ha), i.e. two-layered stands were replaced by single-layered ones. The increasing outbreak also caused the dieback of entire stands, which was reflected, among other things, in an increase in the total area of gaps in the stands of the Białowieża Forest by 412 ha. The area of gaps increased in managed forests (in the Białowieża Forest District - by 136 ha, in the Browsk Forest District - by 141 ha, in the Hajnówka Forest District - by 188 ha), while it decreased in the Białowieża National Park, where the total area of gaps decreased by over 53 ha.

The analyses presented in this chapter indicate dynamic changes in forest stands in the Polish part of the Białowieża Forest during the study period. Such dynamic changes in stand structure have certainly created new conditions for tree growth in the area (see Spies et al. 1990; Bertemucci et al. 2002; Dobrowolska and Veblen 2008). It can be expected that in the coming years the cleared areas, if not occupied by e.g. reed grass *Calamagrostis* spp., will be colonised by new trees, which may lead to stands with a different species composition than the current stands.

9.6. Conclusion

The use of remote sensing data to monitor stand dynamics - even of such complex structure and species diversity - is justified and provides a complete and consistent record of change. An important element in the use of remote sensing data is access to qualified specialists and data analysis tools. The standard GIS (Geographic Information System) and remote sensing software used for spatial analysis does not include some of the tools that were used in the ForBioSensing project. Therefore, the project created numerous applications, mostly in R, which methodically supported the analytical activities and automated many work steps.

Airborne laser scanning data was used to determine the dynamics of the growing stock of living and dead trees in the Polish part of the Białowieża Forest between 2015 and 2019. During this period, the total volume of living trees in the entire area analysed, calculated on the basis of remote sensing data, decreased by 8.5% (2.09 million m³), while the volume of dead trees increased by 147.7%. The decrease in the volume of live trees was the same in all forest districts and amounted to about 10%, while in the Białowieża National Park it occurred only to a small extent, almost 3,000 m³.

The usefulness of airborne laser scanning data for species composition analysis was confirmed, based on three species groups: deciduous trees, pines and spruces. The project attempted to classify selected tree species using ALS point data for the first time in an area where dense stands clearly predominate, with very optimistic results.

Airborne laser scanning data were also used to analyse changes in the size and location of gaps in the stands of the Białowieża Forest. The total number of gaps in 2015-2019 decreased from 254,016 to 252,006, while the total area of gaps increased by more than 412 ha and amounted to 2602 ha in 2019, which is about 4.2% of the area of the Polish part of the Białowieża Forest. From this we could conclude that in most cases the gaps are expanding and merging together, which is mainly due to the dieback of spruce stands as a result of progressive bark beetle outbreak.

Based on the analysis of airborne laser scanning data, a change in stand structure from a multi-layered structure to a single-layered structure was also observed between 2015-2019. This was often associated with the death of spruce in the upper layer of the stand and the emergence of a second storey, resulting in a simplification of the stand structure. Most such changes occurred in the Białowieża Forest District (906 ha), the fewest in the Białowieża National Park (440 ha). The structure changed on an area of 3,000 ha in the Polish part of the Białowieża Forest.

The use of remote sensing data requires quality control. Data providers make mistakes when processing the data. The result is data of poorer quality, which in extreme cases is unusable. The process of quality control itself prolongs tasks, so it must be included in the process of purchasing and receiving remote sensing data.

References

- Anonymous 1887. Verwendung der Ballonphotographie zu forstwirtschaftlichen Zwecken. *Zeitschrift für Luftschiffahrt und Physik der Atmosphäre*, 6: 285–286
- Balenović I., Seletković A., Pernar R., Marjanović H., Vuletić D., Paladinić E., & Benko M. 2011. Digital photogrammetry—State of the art and potential for application in forest management in Croatia. *South-east European forestry: SEEFOR*, 2(2): 81–93.
- Bertemucci P., Coates K.G., Harper K.A. & Wright E.F. 2002. Gap disturbances in northern old-growth forests of British Columbia, Canada. *Journal of Vegetation Science*, 13(5): 685–696.
- Będkowski K. 2015. The history of the development of photogrammetry and remote sensing in Polish forestry. *Teledetekcja Środowiska* 52: 5-15. [in Polish]
- Bohlin J., Wallerman J., Fransson J.E.S. 2012. Forest variable estimation using photogrammetric matching of digital aerial images in combination with a high-resolution DEM. *Scandinavian Journal of Forest Research*, 27(7): 692–699.
- Cochran W.G. 1977. *Sampling techniques* (3rd Edition). John Wiley & Sons, New York.
- Corona P., Fattorini L. 2008. Area-based lidar-assisted estimation of forest standing volume. *Canadian Journal of Forest Research*, 38: 2911–2916.
- Dalponte M., Bruzzone L., Gianelle D. 2008. Fusion of hyperspectral and LIDAR remote sensing data for classification of complex forest areas. *IEEE Transactions on Geoscience and Remote Sensing*, 46: 1416–1427. <https://doi.org/10.1109/TGRS.2008.916480>.
- Dobrowolska D., Veblen T.T. 2008. Treefall-gap structure and regeneration in mixed *Abies alba* stands in central Poland. *Forest Ecology and Management*, 255: 3469–3476.
- Erfaniferad Y., Stereńczak K., Kraszewski B., Kamińska A. 2018. Development of a robust canopy height model derived from ALS point clouds for predicting individual crown attributes at the species level. *International Journal of Remote Sensing*. <https://doi.org/10.1080/01431161.2018.1508916>.
- Erfaniferad Y., Stereńczak K., Miścicki S. 2019. Management strategies alter competitive interactions and structural properties of Norway spruce in mixed stands of Białowieża Forest, Poland. *Forest Ecology and Management*, 437: 87–98.
- Fassnacht F.E., Latifi H., Stereńczak K., Modzelewska A., Lefsky M., Waser L.T., Straub C., Ghosh A. 2016. Review of studies on tree species classification from remotely sensed data. *Remote Sensing and Environment*, 186. <https://doi.org/10.1016/j.rse.2016.08.013>.
- Grodzki W. 2016. Mass outbreaks of the spruce bark beetle *Ips typographus* in the context of the controversies around the Białowieża Primeval Forest. *Forest Research Paper*, 77(4): 324–331.
- Heinzel J., Koch B. 2012. Investigating multiple data sources for tree species classification in temperate forest and use for single tree delineation. *International Journal of Applied Earth Observation and Geoinformation*, 18: 101–110. <https://doi.org/10.1016/j.jag.2012.01.025>.
- Holmgren J., Barth A., Larsson H., Olsson H. 2012. Prediction of stem attributes by combining airborne laser scanning and measurements from harvesters. *Silva Fennica*, 46(2): 227–239.

- Hycza T., Stereńczak K., Bałazy R. 2018. Potential use of hyperspectral data to classify forest tree species. *New Zealand Journal of Forestry Science*. <https://doi.org/10.1186/s40490-018-0123-9>
- Hyypä J., Inkinen, M. 1999. Detecting and estimating attributes for single trees using laser scanner. *Photogrammetric Journal of Finland*, 16: 27–42.
- Kamińska A., Lisiewicz M., Stereńczak K., Kraszewski B., Sadkowski R. 2018. Species-related single dead tree detection using multi-temporal ALS data and CIR imagery. *Remote Sensing of Environment*, 219: 31–43. <https://doi.org/10.1016/j.rse.2018.10.005>.
- Kamińska A., Lisiewicz M., Kraszewski B., Stereńczak K. 2020. Habitat and stand factors related to spatial dynamics of Norway spruce dieback driven by *Ips typographus* (L.) in the Białowieża Forest District. *Forest Ecology and Management*, 476, 118432. <https://doi.org/10.1016/j.foreco.2020.118432>.
- Kamińska A., Lisiewicz M., Kraszewski B., Stereńczak K. 2021. Mass outbreaks and factors related to the spatial dynamics of spruce bark beetle (*Ips typographus*) dieback considering diverse management regimes in the Białowieża Forest. *Forest Ecology and Management*, 498, 119530. <https://doi.org/10.1016/j.foreco.2021.119530>.
- Kraszewski B., Piasacecka Ż., Sadkowski R., Stereńczak K. 2020. Automatic Airborne Laser Scanning Data Quality Control Procedure for Environmental Studies. *Folia Forestalia Polonica, Series A* 62(4):317-326. doi: 10.2478/ffp-2020-0030
- Kneizys F.X., Shettle E.P., Abreu L.W., Chetwynd J.H., Anderson G.P., Gallery W.O., Selby J.E.A., Clough S. A., 1988. Users Guide to LOWTRAN 7. Air Force Geophysics Laboratory, Hanscom Air Force Base, Massachusetts.
- Laurin G.V., Puletti N., Grotti M., Stereńczak K., Modzelewska A., Lisiewicz M., Sadkowski R., Kuberski Ł., Chirici G., Papale D. 2020. Species dominance and above ground biomass in the Białowieża Forest, Poland, described by airborne hyperspectral and lidar data. 2020, *International Journal of Applied Earth Observations and Geoinformation*, 92, 102178. <https://doi.org/10.1016/j.jag.2020.102178>
- Lechner A.M., Giles M. Foody G.M, Boyd D.S. 2020. Applications in Remote Sensing to Forest Ecology and Management. *One Earth*, 2(5): 405–412. <https://doi.org/10.1016/j.oneear.2020.05.001>.
- Lindberg E., Hollaus M. 2012. Comparison of Methods for Estimation of Stem Volume, Stem Number and Basal Area from Airborne Laser Scanning Data in a Hemi-Boreal Forest. *Remote Sensing*, 4: 1004–1023.
- Mielcarek M., Stereńczak K., Khosravipour A. 2018. Testing and evaluating different LiDAR-derived canopy height model generation methods for tree height estimation. *International Journal of Applied Earth Observations and Geoinformation*, 71: 132–143.
- Mielcarek M., Kamińska A., Stereńczak K. 2020. Digital aerial photogrammetry (DAP) and airborne laser scanning (ALS) as sources of information about tree height – comparisons of the accuracy of remote sensing methods for tree height estimation. *Remote Sensing*, 12, 1808. <https://doi.org/10.3390/rs12111808>.
- Modzelewska A., Fassnacht F.E., Stereńczak K. 2020. Tree Species Identification within an extensive forest area using airborne hyperspectral data. *International Journal of Applied Earth Observations and Geoinformation* 84, 101960. <https://doi.org/10.1016/j.jag.2019.101960>.
- Modzelewska A., Kamińska A., Fassnacht F.E., Stereńczak K. 2021. Multi-temporal hyperspectral tree species classification in the Białowieża Forest World Heritage site. *Forestry: An International Journal of Forest Research*, cpaa048. <https://doi.org/10.1093/forestry/cpaa048>.
- Næsset E. 2002. Predicting forest stand characteristics with airborne scanning laser using a practical two-stage procedure and field data. *Remote Sensing of Environment* 80: 88–99.
- Nelson R., Krabill W., Tonelli J. 1988. Estimating forest biomass and volume using airborne laser data. *Remote Sensing of Environment* 24: 247–267. [https://doi.org/10.1016/0034-4257\(88\)90028-4](https://doi.org/10.1016/0034-4257(88)90028-4).
- Nowakowska J.A., Hsiang T., Patynek P., Stereńczak K., Olejarski I., Oszako T. 2020. Health Assessment and Genetic Structure of Monumental Norway Spruce Trees during A Bark Beetle (*Ips typographus* L.) Outbreak in the Białowieża Forest District, Poland. *Forests*, 11, 647. DOI: 10.3390/f11060647.
- Olpenda A., Stereńczak K., Będkowski K. 2019. Estimation of Sub-canopy Solar Radiation from LiDAR Discrete Returns in Mixed Temporal Forest of Białowieża, Poland. *International Journal of Applied Earth Observations and Geoinformation*, 79: 116–132.
- Packalen P., Maltamo M. 2007. The k-MSN method for the prediction of species-specific stand attributes using airborne laser scanning and aerial photographs, *Remote Sensing of Environment*, 109: 328–441.
- Parkitna K., Krok G., Lisańczuk M., Mitelsztedt K., Ukalski K., Magnussen S., Markiewicz A., Miścicki S., Stereńczak K. 2021. Modelling growing stock volume of forest stands with the use of selected LiDAR Area Based Approaches in various predictive models. *Forestry: An International Journal of Forest Research*. <https://doi.org/10.1093/forestry/cpab01>.
- Potapov P., Yaroshenko A., Turubanov S., Dubinin M., Laestadius L., Thies C., Aksenov D., Egorov A., Yesipova Y., Glushkov I., Karpachevskiy M., Kostikova A., Manisha A., Tsybikova E., Zhuravleva I. 2008. Mapping the world's intact forest landscapes by remote sensing. *Ecology and Society* 13(2): 51. <https://doi.org/10.5751/ES-02670-130251>.
- Seely H.E. 1935. Use of aerial photographs for forestry purposes. *Forestry Chronicle*, 11: 287.
- Seely H.E. 1929. Computing tree heights from shadow in aerial photographs. *Forestry Chronicle*, 5: 24–27.
- Spurr S.H. 1948. *Aerial photographs in forestry*. New York.
- Spies T.A., Franklin J.F. and Klopsch M. 1990. Canopy gaps in Douglas-fir forests of the Cascade Mountains. *Canadian Journal of Forest Research*, 20: 649–658.
- Stereńczak K. 2010. Technologia lotniczego skanowania laserowego jako źródło danych w półautomatycznej inwentaryzacji lasu. *Sylwan*, 154(2): 88–99.
- Stereńczak K., Zasada M. 2011. Accuracy of tree height estimation based on LIDAR data analysis. *Folia Forestalia Polonica, Series A-Forestry*, 53(2): 123–129.

- Stereńczak, K., Miścicki, S. 2012. Crown delineation influence on standing volume calculations in protected area, International Archives of the Photogrammetry, Remote Sensing and Spatial Information Sciences, Volume XXXIX-B8, 2012, XXII ISPRS Congress, 25 August – 01 September 2012, Melbourne, Australia.
- Stereńczak K., Kraszewski B., Mielcarek M., Piasecka Ż. 2017. Inventory of standing dead trees in the surroundings of communication routes – remote sensing contribution to the potential risk assessment. *Forest Ecology and Management*, 402: 76–91. <https://doi.org/10.1016/j.foreco.2017.07.018>
- Stereńczak K., Mielcarek M., Modzelewska A., Kraszewski B., Fassnacht F.E., Hilszczański J. 2019. Intra-annual *Ips typographus* outbreak monitoring using multi-temporal GIS analysis based on hyperspectral and ALS data in the Białowieża Forests. *Forest Ecology and Management*, 442: 105–116.
- Stereńczak K., Kraszewski B., Mielcarek M., Piasecka Ż., Lisiewicz M., Heurich M. 2020a. Mapping individual trees with airborne laser scanning data in an European lowland forest using a self-calibration algorithm. *International Journal of Applied Earth Observations and Geoinformation*, 93, 102191. <https://doi.org/10.1016/j.jag.2020.102191>.
- Stereńczak K., Mielcarek M., Kamińska A., Kraszewski B., Piasecka Ż., Miścicki S., Heurich M. 2020b. Influence of selected habitat and stand factors on bark beetle *Ips typographus* (L.) outbreak in the Białowieża Forest. *Forest Ecology and Management*, 459, 117826. <https://doi.org/10.1016/j.foreco.2019.117826>.
- Sołoduchin W. I., Kulasow A. G., Utenkow B. I., Żukow A. J., Mażugin I. N., Emalanow W. P., Kopolow I. A. 1977. Sjomka profila krony dieriewa s pomoszczju lazirnego dalnomiera. *Lesnoje Choziajstwo* 2: 71-73.
- Sołoduchin W. I., Mażugin I. N., Żukow A. J., Narkiewicz W. I., Popow J. W., Kulasow A. G., Marasin L. E., Sokołow S. A. 1979a. Laziernaja aerosionka profilej lesa. *Lesnoje Choziajstwo* 10: 43-45.
- Sołoduchin W. I., Żukow A. J., Mażugin I. N., Bokow T. K., Poleżaj W. M. 1979b. Wozmożnosti lazirnoj aerosiemki profilej lesa. *Lesnoje Choziajstwo* 10: 53-58.
- Tan L., Jiang J. 2019. *Digital Signal Processing, Fundamentals and Applications*. Academic Press. <https://doi.org/10.1016/C2017-0-02319-4>.
- White J.C., Wulder M.A., Varhola A., Vastaranta M., Coops N.C., Cook B.D., Pitt D., Woods M. 2013. A best practices guide for generating forest inventory attributes from airborne laser scanning data using an area-based approach. *The Forestry Chronicle*, 89: 722–723.
- Wulder M.A., Dymond C.C., White J.C., Leckie D.G., & Caroll A.L. 2006. Surveying mountain pine beetle damage of forests: A review of remote sensing opportunities. *Forest Ecology and Management*, 221: 27–41.
- Wulder M.A., Bater C.W., Coops N.C., Hilker T., White J.C. 2008. The role of LiDAR in sustainable forest management. *The Forestry Chronicle*, 84: 807–826. <https://doi.org/10.5558/tfc84807-6>.

10. Determination of selected tree biometric characteristics on the basis of a single measurement by terrestrial laser scanning

Bartłomiej Kraszewski

Forest Research Institute, Department of Geomatics, Sękocin Stary, 3 Braci Leśnej St., 05-090 Raszyn
b.kraszewski@ibles.waw.pl

Abstract

Knowledge of the characteristics of individual trees in sample plots is important information that provides a reference base for large-scale analyses of forest environments. Measurement with the inventory methods used so far, based on the use of measuring devices such as compasses, forest calipers, altimeters and range finders, is time-consuming and generates high acquisition costs. With the advent of terrestrial laser scanning technology, it has become possible to use sets of 3D points to extract these features faster using computer algorithms. The main objective of the analysis presented in this chapter was to establish the possibility of detecting a single tree and determining its basic biometric characteristics: diameter at breast height, height and volume. The tests were carried out on 99 sample plots in the Polish part of Białowieża Forest, where inventory measurements were carried out during the fully-leafed period in 2015, 2017 and 2019. Tree detection was performed with a proprietary algorithm and its accuracy was verified using reference measurement data collected using traditional techniques. In addition, having a collection of almost 4597 trees, the influence of the distance of the tree from the scanner and the size of its diameter at breast height on the accuracy of the determination of the features of this specimen was analysed. The study concluded that a random single tree can be detected with an average accuracy of 61.5% on the basis of a terrestrial laser scanner measurement. The error in diameter at breast height measurement was on average 10% of the measured value, while the volume was 39%. The tree height determined from the TLS data was on average about 40% lower than the reference height, whereas from the ALS data it was 12% lower. The errors in diameter and volume measurements were not dependent on the distance between the tree and the scanner. In conclusion, the single station measurement is sufficient to determine the diameter and location of a tree with satisfactory accuracy. However, for more detailed analyses it is necessary to obtain data from more sites or during the leafless period.

10.1. Introduction

Field measurement of trees on sample plots plays a significant role in the study of forest ecosystems as well as in forest condition monitoring and management of forest areas. The data collected during this measurement provide knowledge on the structure, distribution and dynamics of forest stands. Tree surveying is usually carried out using traditional methods based on „direct contact” with each object and using altimeters, range finders, compasses and

forest calipers. These methods are expensive and require a lot of time and resources, and the traditional measurement mode significantly limits the number of sites inventoried in one day. With the development of terrestrial laser scanning technology, there has also been a process of implementing it in forest stand inventories to speed up and objectify the data collection process.

The first commercial terrestrial laser scanner was introduced to the market in 1998. This system allowed the measurement of millions of 3D points surrounding the scanner. In recent years there have been significant developments in this technology, involving a reduction in scanning units as well as an increase in spatial resolution and scanning speed, thereby increasing the mobility of scanning stations and broadening the possibilities for their use in various aspects of forestry research.

The biggest advantage of terrestrial laser scanning is the ability to inventory all the trees in a given inventory area quickly, with a high level of accuracy down to a few millimetres. From the acquired data, tree attributes such as diameter at breast height, tree height, stem curve, etc. can be automatically obtained (Liang et al. 2013).

To date, there have been many scientific papers devoted to the automatic analysis of terrestrial laser scanning data in forest environments. Most of these publications deal with the process of obtaining attributes to describe a stand or individual trees from which productivity and changes in forest structure can be determined. The first publications focused specifically on Terrestrial Laser Scanning (TLS) data mining to extract simple attributes such as diameter at breast height and height (Erikson and Karin, 2003; Lovell et al, 2003; Simonse et al, 2003; Aschoff and Spiecker, 2004; Hopkinson et al. 2004; Pfeifer et al. 2004; Parker et al. 2004; Schütt et al. 2004; Thies et al. 2004; Watt and Donoghue 2005). Later, authors began to extract more detailed attributes from these data, such as stem curve based on cross-sections (Liang et al. 2013). Subsequently, it has been demonstrated that TLS data can be a good source of information for determining volume and biomass at the sample plot and individual tree level (Yu et al. 2013; Kankare et al. 2013; Astrup et al. 2014; Liang et al. 2014b).

In 2018, a publication (Liang et al. 2018) comprehensively analysed multiple methods for single tree attribute detection from TLS data. The analysis was carried out for different stand types and for different data types (single and multi-scanning). Detection accuracy was evaluated using two parameters: completeness (determines which part of the trees recognised using the algorithm is referenced in the reference) and correctness (determines how many trees out of all detected trees is correct). Based on the results obtained, it was found that single scans can detect trees with 75% completeness and 90% correctness for easy stands (600 trees/ha, 20 cm mean diameter at breast height), with 60% completeness and 90% correctness for medium stands (1000 trees/ha, 15 cm mean diameter at breast height) and with 30% completeness and 90% correctness for difficult stands (2000 trees/ha, 10 cm mean diameter at breast height). When data from multiple sites are acquired, completeness increases to 90% for medium stands and 70% for difficult stands with 100% correctness, and existing algorithms were able to determine the diameter at breast height and the stem curve to within 1-2 cm.

The work carried out within the project focused on the possibility of determining basic tree attributes on 99 sample plots of varying structure. Attributes such as tree location, diameter at breast height and volume were determined (based on the formula determined in the RemBioFor project on model trees). The data were analysed in terms of the dependence of diameter at breast height and volume values on distance from the scanner, as well as on diameter size.

10.2. Materials and Methods

10.2.1. TLS data

Terrestrial laser scanning (TLS) data were acquired between 2015 and 2019 in three survey campaigns (2015, 2017, 2019). These data were obtained for 99 circular inventory plots distributed in the Polish part of Białowieża Forest (Fig. 10.1).

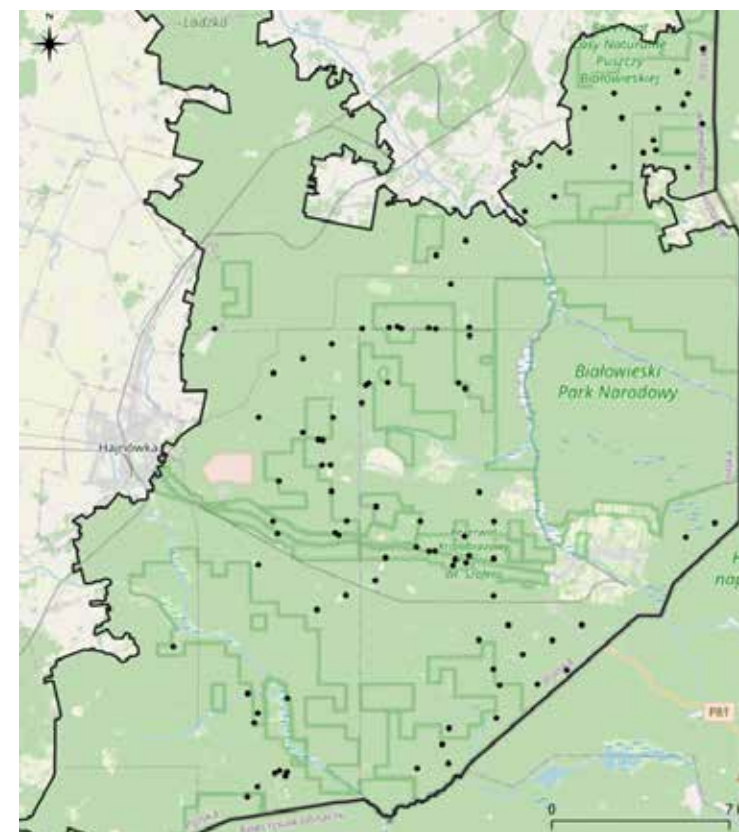

Figure 10.1. Distribution of sample plots where TLS measurements were carried out in the Polish part of Białowieża Forest

The scans were performed with a Trimble TX5 phase scanner (Fig. 10.2). The scanner scanned the area over its entire range, i.e. for the horizontal angle (from 0 to 360 degrees) and for the vertical angle (from -60 to 90 degrees). The scanning resolution was 6.1mm/10m, giving 28.4 points/degree. The total scan size was 10314 x 4298 points (approximately 44 million points). A single scan was taken for each sample plot, for which additional images were acquired. The scanning time per site was approximately 8 minutes (Fig. 10.2).



Figure 10.2. Trimble TX5 phase scanner in the process of performing a scan on a sample plot (photo Kamil Pilch)

Point sets acquired in the field were processed using dedicated software FARO Scene 6.0. Processing consisted of pre-filtering the outlier points using a Grid filter, colouring the point cloud using the images acquired by the scanner, and exporting the data to a text file containing the XYZ coordinates, intensity value and RGB from the images. The exported text files were then saved in LAZ format. In order to standardise the resolution of the point cloud, while reducing its size for processing, it was generalised using a 1cm voxel grid.

10.2.2. Detection of trees and their parameters

Single tree detection on the 2015 TLS data was carried out using a proprietary algorithm developed as part of the project. The algorithm first generated a Digital Terrain Model (DTM) for each circular sample plot and then normalised the obtained point clouds using it. The normalised dataset was filtered using normal and statistical vector information and the geometric distribution of points. In the final stage, the filtered set of points was divided into smaller subsets into which cylinders were fitted by the RANSAC method. For the matched cylinders, the intersections of the main axis of the solid with the plane $z = 1.3$ m (centre of the tree) were determined.

For each of the detected trees, the volume was then calculated using a different developed algorithm, which first cut out a point cloud with a radius of 0.5 m from a tree centre. RANSAC (Fisher and Bolles, 1981) was then used to fit circles into the point cloud sections cut off every 10 cm, counting from 0 to the maximum height of the cut-out. For each fitted circle, its position and radius were recorded. This information was then used to filter outliers. To do this, a linear model was fitted to the groups of values (z , radius), (z , x), (z , y) with RANSAC (range = 1 cm, $n = 5$, iterations = 100). Sections deviating by 1cm from the radius model and by 2 cm from the models for coordinates were discarded. As a result of filtering, trees containing less than five sections were considered a detection error and removed from further analysis. For the remaining trees, volume was calculated as the sum of the volumes of truncated cones, whose bases were the circles fitted into individual sections based on the following formula:

$$V = \frac{\pi}{3} \cdot h \cdot (R^2 + R \cdot r + r^2)$$

where:

h - height of the truncated cone,

R - base radius,

r - top surface radius.

The volume was calculated for two ranges of sections:

- v – from the ground level (0 m) to the section designated for the highest points, and if there was no value of radius for section 0, a radius from the lowest section of a tree,
- from the ground level (0 m) to the section at the height of 5m, and if there was no value of radius for the 5m section, the radius was determined from a linear model fitted with RANSAC at the value (z , radius).

From $v5m$, the volume of the whole tree was calculated with use of the formula determined within the RemBioFor project:

$$V = -0,08977 + 3,01185 \times v5m$$

For each tree, the DBH (diameter at breast height) was also determined by fitting a circle to the points at 1.3m height, or if there were no points, by determining the radius from a linear model.

The determined position of the trees was used to integrate the results of the terrestrial laser scanning measurements with the terrestrial forest inventory measurements (on the same sample plots) in 2015. For this, an algorithm developed within the project was used, which was based on the iterative finding of groups of four points in two sets (from TLS and field measurements), whose distances, DBH values and azimuths are mutually corresponding within assumed limits. For these assumptions, there were many such corresponding groups in the sets, so the algorithm iteratively matched whole sets with specific trees on the basis of corresponding groups of points and checked the fitting of the remaining trees. The solution with the best fit was selected for the transformation of TLS data to the layout from field measurements. The parameters for the transformation were the XY translation of the scan centre and the rotation angle.

The fitted TLS data from 2015 served as a reference for the transformation of data from subsequent measurement campaigns - in 2017 and 2019. Mutual orientation of sets of points was performed using the Iterative Closest Point (ICP) method (Besl et al. 1992). However, before fitting, the transformed point clouds underwent a normalisation process based on the generated Digital Terrain Model (DTM) from the 2015 data. The reference and processed sets were then generalised to 1 cm resolution. Based on the height values from the DTM, the shift value between the sets along the Z axis was calculated. In the final stage, the sets were filtered using the Statistical Outlier Removal (SOR) filter (Rusu 2013), and points whose neighbourhood did not meet the planarity condition were removed. The filtered sets were integrated using the ICP method.

The mutually integrated TLS data for the period 2015–2019 were then used to calculate the volume of individual trees for each year using the same method as for the 2015 data. A layer containing the location of tree positions and diameter at breast height generated from the 2015 TLS data was used as a starting layer for this process.

The set of individual trees detected on the TLS data in 2015–2019 contained 4597 objects. Such a large set made it possible to analyse the influence of distance from the scanner and diameter at breast height on the accuracy of determining basic tree attributes.

In order to better analyse the accuracy of the diameter at breast height and volume determination from the TLS data, the trees were further divided into four thickness groups:

- group 0 - diameter at breast height 70-150 mm - 1475 trees;
- group 1 - diameter at breast height 150-300 mm - 2018 trees;
- group 2 - diameter at breast height 300-450 mm - 757 trees;
- group 3 - diameter at breast height over 450 mm - 347 trees.

The final processing step was to determine tree heights from the TLS data. TLS cloud points located 0.5 m from the tree location were used for this. The maximum value of the Z coordinate of these points was taken to be the height of the tree.

The integration of TLS data with reference measurements also allows the height of the trees in the highest storey of the stand to be determined from airborne laser scanning data, or more precisely from the segmentation product derived from this data. For this purpose, a segment containing this tree trunk is defined for each tree location with TLS. The tree is then assigned the height determined from the Crown Height Model (CHM) for the segment. However, some trees are below the highest storey of the stand and the height determined for them is incorrect. In order to eliminate such cases, a formula determining the height of the tree on the basis of the known diameter at breast height, determined on the basis of the inventory measurements on all plots, was used (the accuracy of the model fit was $R^2 = 0.7972$):

$$h = 11,496 \times \ln(\text{dbh}_{\text{TLS}}) - 40,998$$

When the difference in height from the segments and from the formula was not within the range (-2.5 m; 2.5 m), height was not assigned.

10.2.3. Method of validating results

Tree detection accuracy was evaluated using three measures proposed by Liang et al. (2018): completeness, correctness and average accuracy. Completeness determines what proportion of trees detected using the algorithm have a reference in the reference data. Correctness, on the other hand, determines how many trees out of all those detected are correct. Completeness and correctness are defined by the formula:

$$\text{Completeness} = \frac{n_{cor}}{n_{ref}}$$

$$\text{Correctness} = \frac{n_{cor}}{n_{det}}$$

where:

n_{cor} – number of trees correctly detected from the TLS data;

n_{ref} – number of reference trees measured in the field;

n_{det} – number of all trees detected from the TLS data.

The average detection accuracy determines the correctness of the detection of a randomly selected reference tree. It is defined as:

$$\text{Average accuracy} = \frac{2 \cdot n_{cor}}{n_{ref} + n_{det}}$$

The accuracy of tree position, diameter at breast height, tree height and volume was assessed according to the methodology proposed by Liang et al. (2018) using RMSE (root mean square error) and bias. Accuracy scores were calculated by comparing the detected value \hat{y}_i with the field measured y_i (i is the tree index). RMSE was determined from the formula:

$$RMSE = \sqrt{\frac{1}{n_{det}} \sum_{i=1}^{n_{det}} (\hat{y}_i - y_i)^2}$$

Bias was determined by the formula:

$$Bias = \frac{1}{n_{det}} \sum_{i=1}^{n_{det}} (\hat{y}_i - y_i)$$

In addition, the relative value of RMSE and Bias in percentage was calculated, which is a comparison of them to the average reference value \bar{y} , defined as:

$$\bar{y} = \frac{1}{n_{det}} \sum_{i=1}^{n_{det}} y_i$$

RMSE% was calculated from the formula:

$$RMSE\% = \frac{RMSE}{\bar{y}} \cdot 100\%$$

Bias% was calculated from the formula

$$Bias\% = \frac{Bias}{\bar{y}} \cdot 100\%$$

Due to the stand structure on the validation sample plots they were divided into three groups:

- easy structure - sample plots with clear visibility of tree trunks and low stem density (20 plots),
- medium structure - sample plots with moderate stem density and moderate undergrowth density (50 plots),
- difficult structure - plots with high stem density and dense undergrowth vegetation (29 plots) (Fig. 10.3).

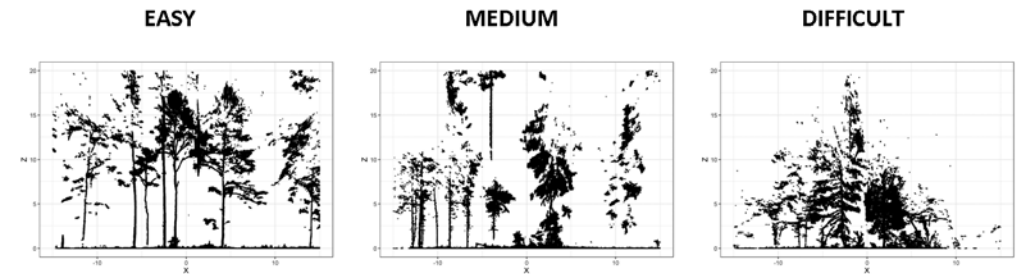

Figure 10.3. Profiles through point clouds for three different types of sample plots, defined by the structure of the stands growing on them

An assessment of the accuracy of the detection of individual trees and their attributes in the sample plots from the TLS data was carried out only for the 2015 survey campaign, which was the benchmark survey.

10.3. Results

10.3.1. Tree detection accuracy

The correctness of tree detection on all types of sample plots was performed to a very high level - more than 80%. For the easy and medium structure plots, the correctness was the same at 90%. Regarding the other two parameters - completeness and average accuracy - a decrease was evident as the density of vegetation in the plot increased. For completeness, values ranged from 60% for easy plots to 37% for difficult plots. The average accuracy of the easy plots was 71% and decreased by 6% for the medium plots and by as much as 22% for the difficult plots (Fig. 10.4).

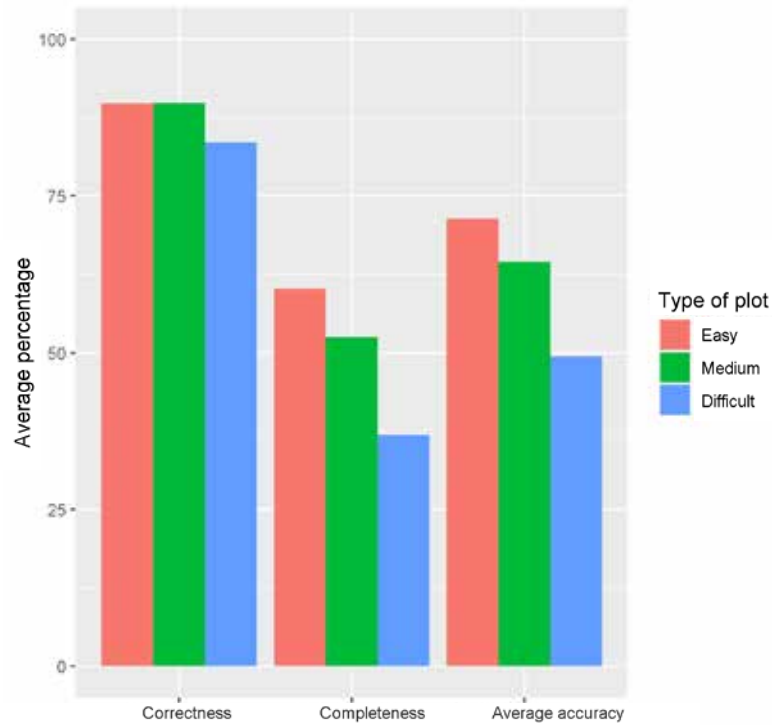

Figure 10.4. Summary of mean values of parameters determining the accuracy of tree detection using TLS data for particular types of sample plots in the Polish part of Białowieża Forest (cf. Fig. 10.1 and Fig. 10.3)

10.3.2. Accuracy of tree location, diameter at breast height and volume

In the analysis of the results, a decrease in localization accuracy expressed by RMSE was evident as vegetation density increased for medium plots by 1 cm and difficult plots by 3 cm compared to easy plots. At the same time, the accuracy of determining the position of the tree was performed on average with an $RMSE_{xy}$ of 18 cm. In all cases the measurement had a systematic error of 1 cm (Tab. 10.1).

Table 10.1. Accuracy of determining the location of trees using TLS data for particular types of sample plots in the Polish part of Białowieża Forest (compare Fig. 10.1 and Fig. 10.3).

Type of plot	$RMSE_x$ [cm]	$RMSE_y$ [cm]	$RMSE_{xy}$ [cm]	$Bias_x$ [cm]	$Bias_y$ [cm]
Easy	12.0	12.1	17.1	-1.26	1.13
Medium	12.8	13.1	18.3	-0.36	0.10
Difficult	15.1	13.3	20.1	-1.91	0.66

With regard to diameter at breast height, the RMSE increased as the difficulty of the area increased. However, looking at the RMSE percentage, the accuracy was the same for each group. The systematic error also increased with increasing vegetation density (Tab. 10.2).

Table 10.2. Accuracy of determining the diameter at breast height of trees using TLS data for particular types of sample plots in the Polish part of Białowieża Forest (compare Fig. 10.1 and Fig. 10.3)

Type of plot	$RMSE_{DBH}$ [mm]	$RMSE_{DBH}$ %	$Bias_{DBH}$ [mm]	$Bias_{DBH}$ %
Easy	21.6	10.6	-0.64	-0.31
Medium	25.6	10.5	-1.87	-0.77
Difficult	29.1	10.9	-3.04	-1.14

The volume was also determined less accurately as the difficulty of the plot increased. The RMSE percentage was at a high level - over 50% of the calculated value. The difficulty of the plot on which the measurement was made also influenced the systematic error (Tab. 10.3).

Table 10.3. Accuracy of determining the volume trees using TLS data for particular types of sample plots in the Polish part of Białowieża Forest (compare Fig. 10.1 and Fig. 10.3)

Type of plot	$RMSE_v$ [m ³]	$RMSE_v$ %	$Bias_v$ [m ³]	$Bias_v$ %
Easy	0.32	59.4	-0.052	-9.41
Medium	0.40	50.8	-0.072	-9.07
Difficult	0.56	56.2	-0.127	-12.7

10.3.3. Accuracy of tree height determination

The influence of vegetation density in the sample plot was evident in the accuracy of tree height determination from the TLS data. The denser the vegetation, the higher the RMSE value. At the same time, in relation to the reference values, the RMSE% increased from 33.7% (easy plots) to 45.1% (difficult plots). A significant increase in the systematic error was also evident, increasing 3-fold for medium plots and 4-fold for difficult plots in relation to easy plots (Tab. 10.4).

Table 10.4. Accuracy of determining tree height using TLS data for particular types of sample plots in the Polish part of Białowieża Forest (compare Fig. 10.1 and Fig. 10.3)

Type of plot	RMSE _H [m]	RMSE _H %	Bias _H [m]	Bias _H %
Easy	6.73	33.7	-1.35	-6.77
Medium	8.89	42.1	-3.81	-18.1
Difficult	9.91	45.1	-5.99	-27.3

With regard to the accuracy of tree height determination from ALS on individual types of sample plots, the RMSE value for all types of plots was at the same level - on average 2.6 m, which was two to three times higher than the height determined from TLS. The errors obtained represented on average 12.6% of the value of the determined height. For the most difficult plots, the error accounted for the smallest proportion of the determined height, only 10.4%. For all plots, the systematic error was similar - not exceeding 1 m (Tab. 10.5).

Table 10.5. Accuracy of determining tree height using ALS data for particular types of sample plots in the Polish part of Białowieża Forest (compare Fig. 10.1 and Fig. 10.3).

Type of plot	RMSE _{hALS} [m]	RMSE _{hALS} %	Bias _{hALS} [m]	Bias _{hALS} %
Easy	2.79	13.9	-0.56	-2.8
Medium	2.85	13.5	-0.89	-4.2
Difficult	2.29	10.4	-0.66	-3.0

10.3.4. Dependence of the accuracy of the diameter at breast height and volume of trees on their distance from the scanner

In the analysis of the dependence of the difference between the tree diameter at breast height value determined from the TLS data and that measured in the field on the distance of the tree from the scanner, no apparent deviation was found to depend on this factor. Both the values of the differences and their percentage reference for most trees were distributed close to 0 (Figs. 10.5–10.6).

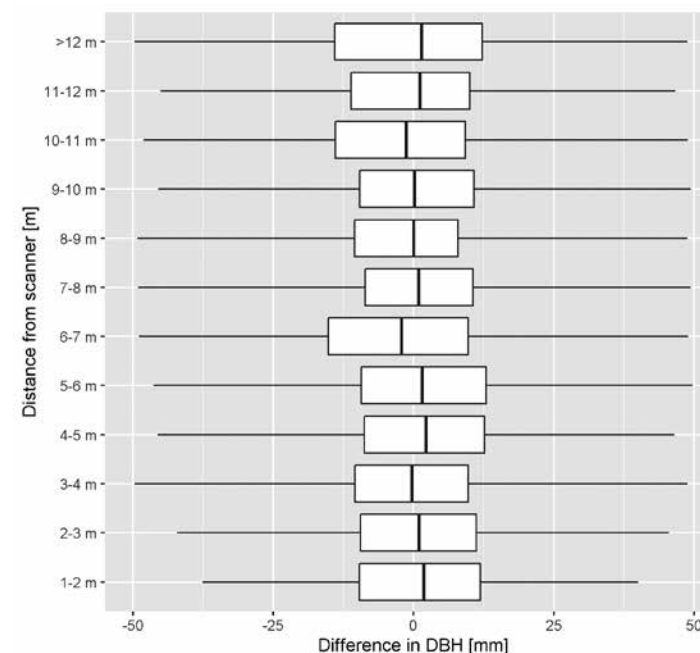

Figure 10.5. Distribution of tree diameter at breast height differences (determined using TLS data and measured in the field in the sample plot) as a function of the distance between the tree and the scanner

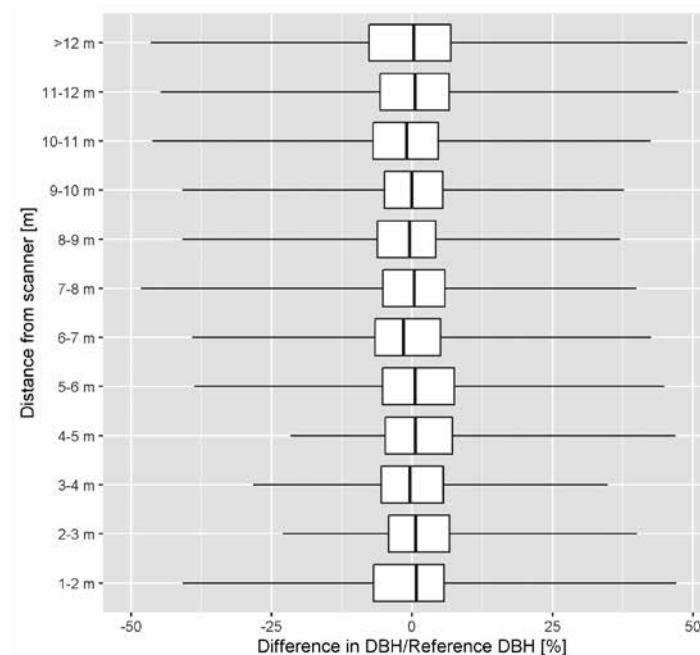

Figure 10.6. Percentage distribution of tree diameter at breast height differences (determined using TLS data and measured in the field in the sample plot) as a function of the distance between the tree and the scanner

With regard to tree volume, there was also no apparent dependence on the distance between the tree and the scanner for the difference in values determined from the TLS data and those calculated on the basis of the field measurements. However, it can be seen that there were many more trees throughout the distance range for which the volume from the TLS data was overestimated (Figs. 10.7–10.8).

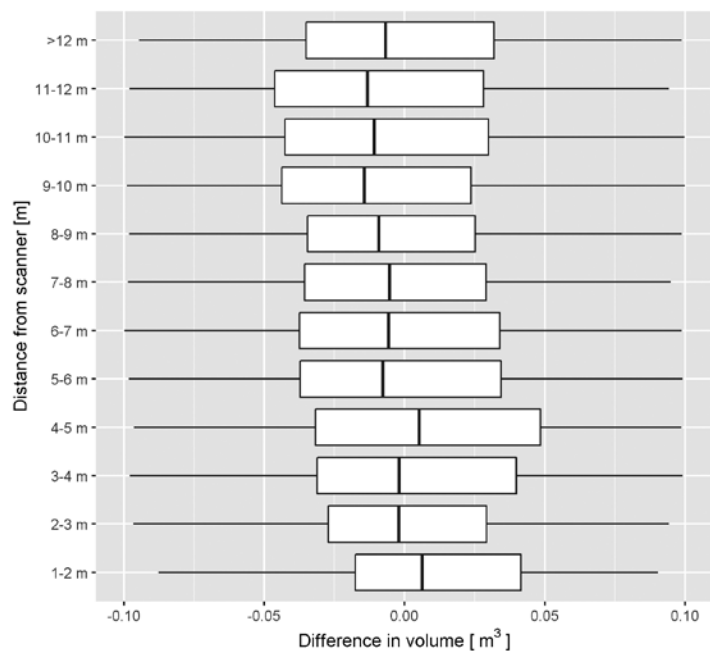

Figure 10.7. Distribution of volume differences (determined using TLS data and calculated on the basis of field measurements on the sample plot) as a function of tree distance from the scanner

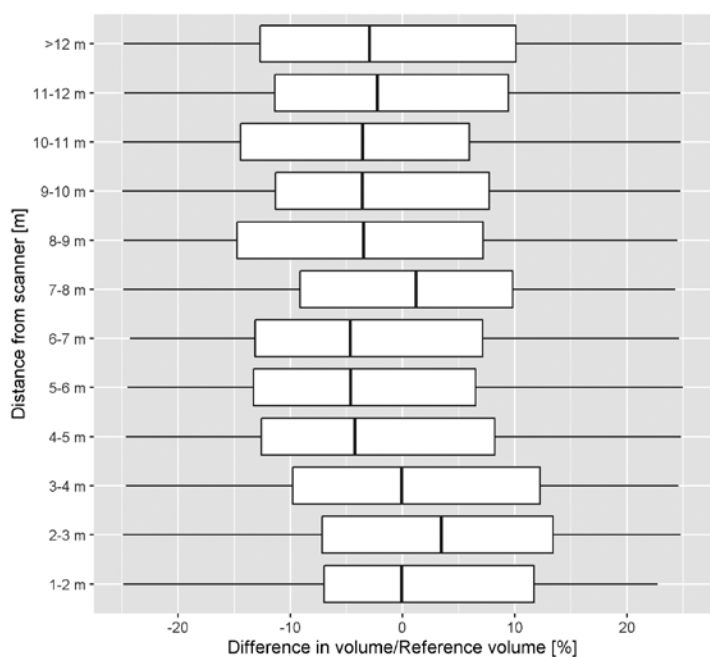

Figure 10.8. Distribution of volume/reference volume differences (determined using TLS data and measured in the field on the sample plot) as a function of tree distance from the scanner

10.3.5. Dependence of the accuracy of the diameter at breast height and volume of trees on diameter at breast height

An analysis of the distribution of differences in tree diameter at breast height values determined from the TLS data and measured in the field revealed a shift in the median value with increasing tree diameter at 1.3 m height (i.e. breast height), as well as a widening of the range of differences with increasing diameter at breast height values. In the case of the ratio of the difference of the value determined from the TLS data to the breast height from the field data, a similar range of values was apparent in each group of tree diameter at breast height with a slight shift in the mean values (Figs. 10.9–10.10).

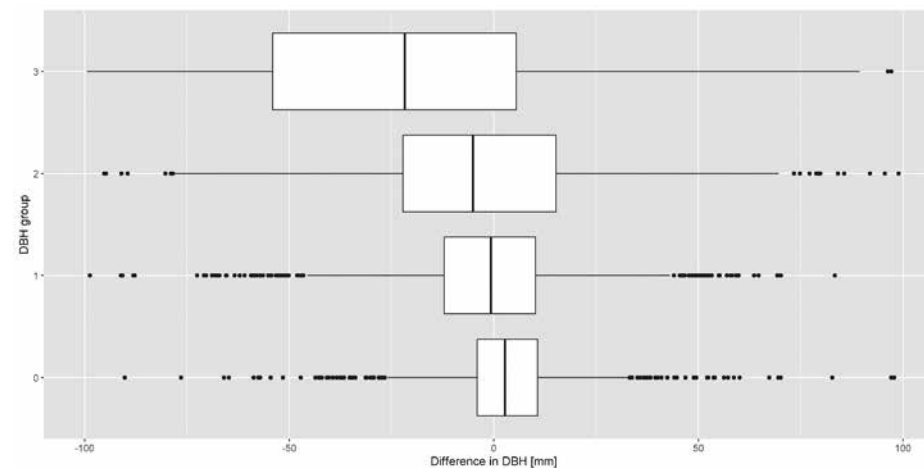

Figure 10.9. Distribution of differences between the TLS-determined diameter at breast height and the reference diameter at breast height by group (group 0 - 70-150 mm, group 1 - 150-300 mm, group 2 - 300-450 mm, group 3 - more than 450 mm)

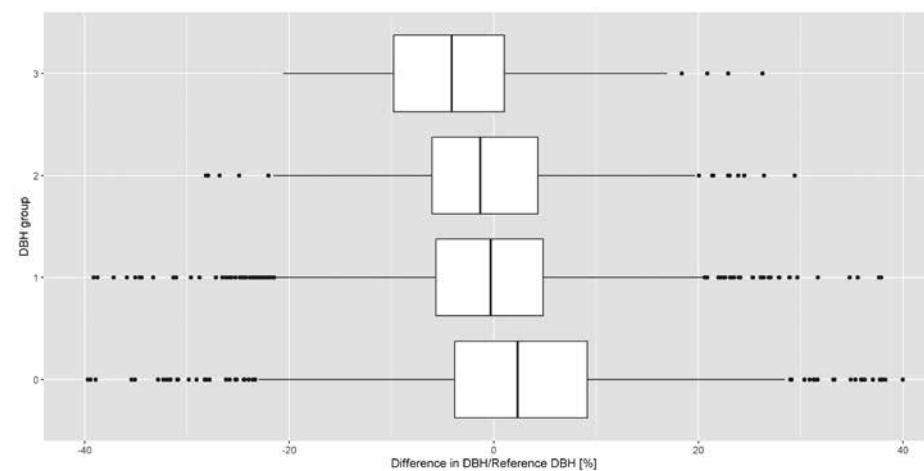

Figure 10.10. Graph of the ratio of the difference to the reference diameter at breast height by DBH group (group 0 - 70-150 mm, group 1 - 150-300 mm, group 2 - 300-450 mm, group 3 - more than 450 mm)

In the case of tree volume, significant differences were apparent between the actual values and those determined from TLS for the two groups of trees with diameter at breast height above 300 mm. For trees with a diameter at breast height greater than 450 mm, an overestimation of volume was also apparent in the TLS data relative to the field data. When comparing the ratio of the difference of the volume values determined from the TLS data to the actual volume, overestimation was evident in all diameters at breast height groups. In addition, group 0 was found to have a larger range of variation in values than the other groups (Figs. 10.11–10.12).

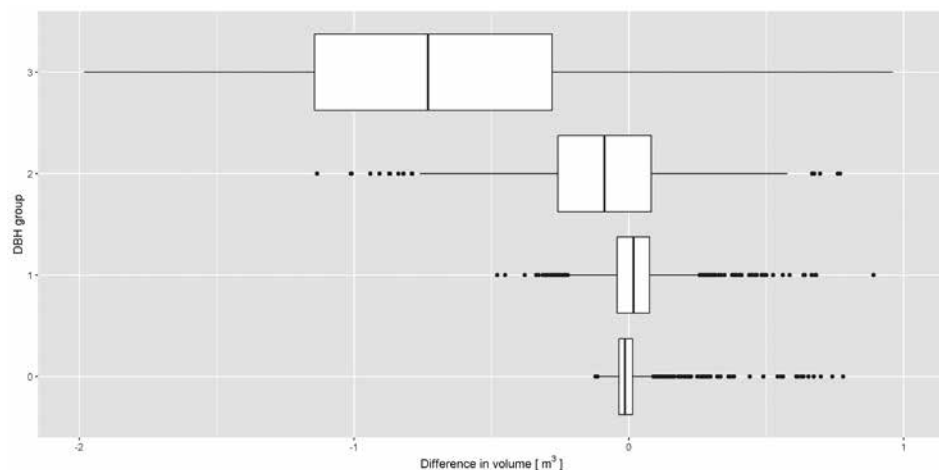

Figure 10.11. Distribution of differences between the volume determined from TLS and the reference volume by DBH group (group 0 - 70-150 mm, group 1 - 150-300 mm, group 2 - 300-450 mm, group 3 - more than 450 mm)

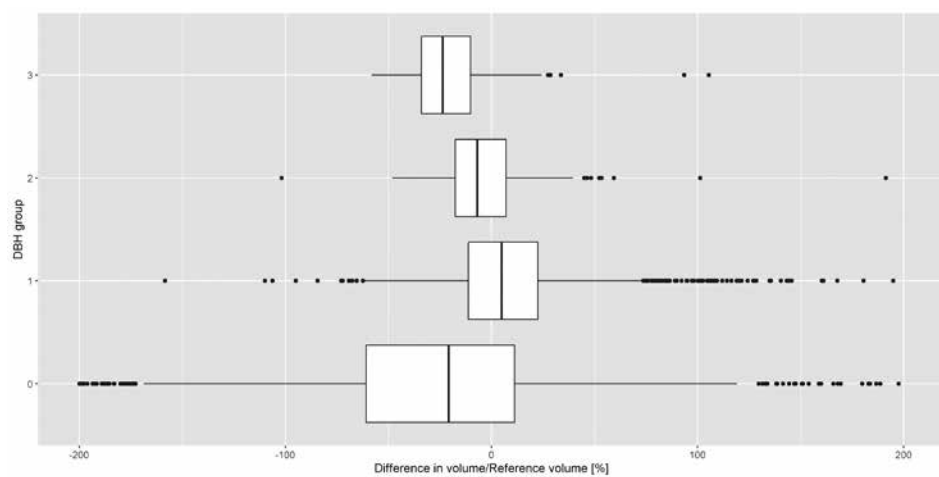

Figure 10.12. Graph of ratio of difference to reference volume by DBH group (group 0 - 70-150 mm, group 1 - 150-300 mm, group 2 - 300-450 mm, group 3 - more than 450 mm)

10.3.6. Change dynamics for the period 2015–2019

Measurements over several years make it possible to analyse changes in diameter at breast height and tree volume over time. The median value for differences with the same sign (cf. Fig. 10.13) was 142.12%, with a range of 75% tree values from 75.0% to 291.4%, indicating that differences from the TLS data were overestimated. Changes in diameter at breast height averaged -2 mm. Most trees were in the 0-200% range (Fig. 10.13).

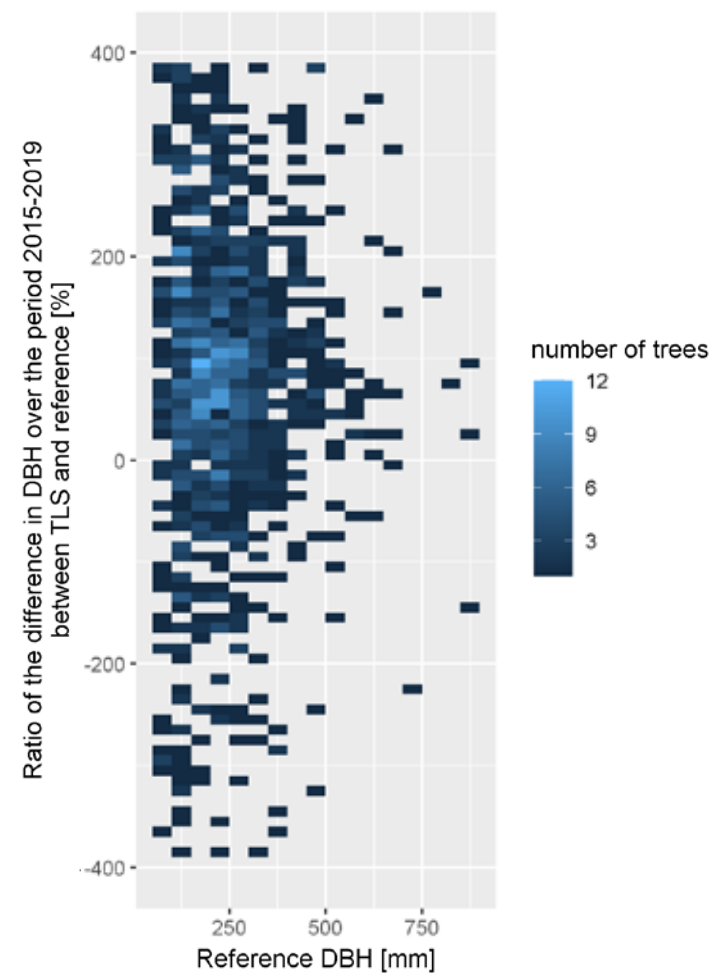

Figure 10.13. Ratio of the difference in single tree diameter at breast height values over the period 2015–2019 from TLS data and reference data (from sample plots) according to diameter at breast height size. Positive percentages refer to the ratio with the same sign. The values below represent differences of opposite signs

For volume, the median value was 107%, with a ratio of between 54% and 244.9% for 75% of the trees. The average volume difference between 2015 and 2019 was -0.03 m^3 . Most trees were between 0 and 100% (Fig. 10.14).

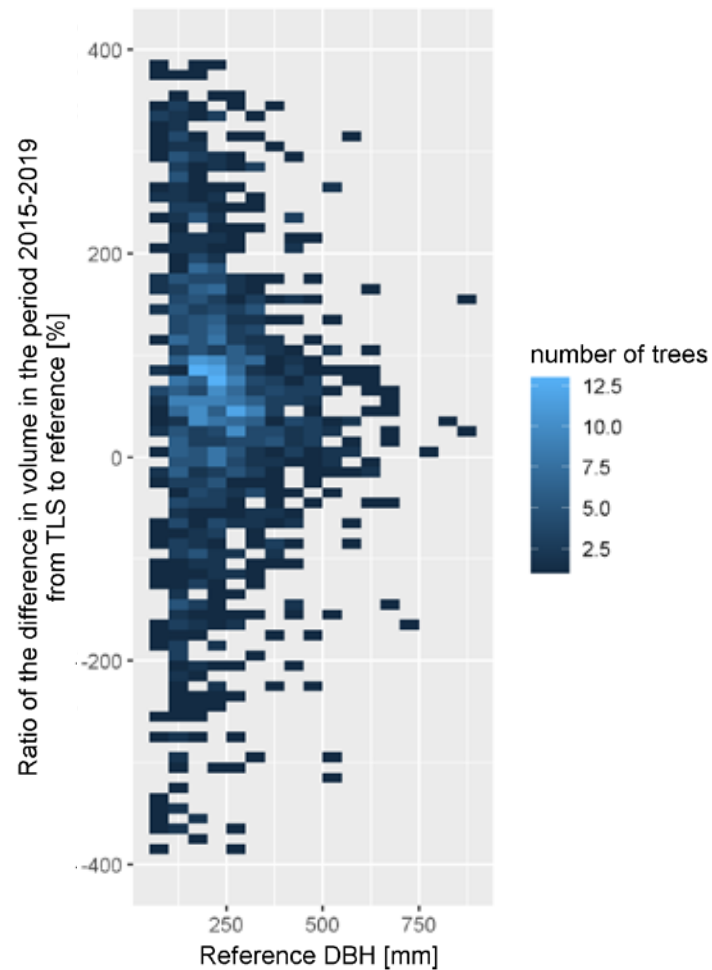

Figure 10.14. Ratio of the difference in volume values of individual trees in the period 2015–2019 from TLS data and from reference data (from sample plots) according to diameter at breast height size. Positive percentages refer to the ratio with the same sign. The values below zero represent differences of opposite signs

10.4. Summary and discussion

Summarising the results of the analysis of the detection of individual trees and their attributes obtained from terrestrial laser scanning data from single scanning sites located in the centre of the sample plots, it should be stated that:

- based on the algorithm developed, an average of 49.5% (completeness) of the trees in each plot can be detected in relation to the reference data. Such a low score in relation to the values presented by Liang et al. (2018) may be due to the specificity of the analysed site, which is not a typical commercial forest with little complex

stand structure. In addition, the result was also influenced by the fact that the data were collected entirely during the growing season. Many plants on the sample plots with the developed assimilative apparatus making it difficult to measure correctly with the terrestrial laser scanner,

- the correctness of tree detection was on average 88% which was equivalent to the correctness obtained by Liang et al. (2018),
- the average accuracy of tree detection was 61.5%, which means that we are able to detect a random reference tree with this probability,
- the accuracy of tree detection decreases as the density of vegetation in the undergrowth increases,
- we are able to determine the diameter at breast height from the TLS data with an RMSE of ± 26 mm, which is consistent with previous publications (Liang et al. 2018), and the measurement error was on average 10% of the measured value,
- the diameter at breast height measurement from the TLS data had a small systematic error Bias of -3.4 mm, representing about 1% of the measured value,
- the height of individual trees from the TLS data can be determined with an accuracy of RMSE ± 8.7 m, which is on average about 40% of the tree height. By integrating TLS and ALS data, it is possible to improve the accuracy of height determination to RMSE = ± 2.5 m (12% of tree height),
- the systematic error in Bias height measurement with TLS had an average value of -4.2 m, and -0.7 m when measured with ALS segments. These errors represented -18% and -3.2% of the measured tree heights, respectively,
- the volume measurement had a RMSE error of ± 0.37 m³, which was on average 39% of the measured value,
- based on automatic tree detection, we are able to map the location of a tree with an accuracy of ± 19 cm,
- the error values for diameter at breast height and volume are not dependent on the distance between the tree and the scanner,
- the size of the difference between the breast height values determined from the TLS data and the field data increases with increasing tree diameter at breast height, although in percentage terms it is not significant. This means that the algorithm is always wrong by the same percentage of the measured diameter at breast height,
- the size of the difference between the volume values determined from the TLS data and the field data increases with increasing tree diameter at breast height, but in percentage terms it behaves the same,
- it is not possible to determine the dynamics of diameter at breast height and volume changes over such a short period as 5 years on the basis of TLS data, because there are significant differences in the results for all groups of trees.

A TLS measurement from a single site is a sufficient data set to determine the diameter at breast height, location and volume of individual trees. For more detailed analyses and to improve the accuracy of the determination it is necessary to acquire data from a larger number of sites, albeit with an increase in the time taken to acquire the data. Improved detection accuracy can also be achieved by acquiring data during the leafless period when other plants and tree foliage will not interfere with the ground scanner measurement.

10.5. Acknowledgements

I would like to thank all the staff of the ForBioSensing project who participated in the acquisition of the terrestrial laser scanner data and the inventory measurements on the sample plots, without which this chapter would not have been written. In particular, I would like to thank: Małgorzata Białczak, Łukasz Kuberski, Miłosz Mielcarek, Aneta Modzelewska, Żaneta Piasecka, Kamil Pilch, Karol Rzczycki and Rafał Sadkowski. I would also like to thank Grzegorz Krok for valuable discussions and support in conducting the research.

References

- Aschoff T., H. Spiecker H. 2004. Algorithms for the automatic detection of trees in laser scanner data. *The International Archives of the Photogrammetry, Remote Sensing and Spatial Information Sciences*: 71–74.
- Astrup R., Ducey M. J., Granhus A., Ritter, T., von Lüpke N. 2014. Approaches for estimating stand-level volume using terrestrial laser scanning in a single-scan mode. *Canadian Journal of Forest Research*, 44(6): 666–676.
- Besl, Paul J., McKay N.D. 1992. A Method for Registration of 3-D Shapes. *IEEE Transactions on Pattern Analysis and Machine Intelligence*. 14 (2): 239–256. DOI:10.1109/34.121791.
- Erikson M., Karin V. 2003. Finding tree-stems in laser range images of young mixed stands to perform selective cleaning. In: *Proceedings of the ScandLaser Scientific Workshop on Airborne Laser Scanning of Forest*: 244–250.
- Fischler M. A., Bolles R.C. 1981. Random sample consensus: a paradigm for model fitting with applications to image analysis and automated cartography. *Communications of the ACM*, 24(6), 381-395.
- Hopkinson C., Chasmer L., Young-Pow C., Treitz P. 2004. Assessing forest metrics with a ground-based scanning lidar. *Canadian Journal of Forest Research*, 34(3): 573–583.
- Kankare V., Holopainen M., Vastaranta M., Puttonen E., Yu X., Hyyppä J., Alho P. 2013. Individual tree biomass estimation using terrestrial laser scanning. *ISPRS Journal of Photogrammetry and Remote Sensing*, 75:64–75.
- Liang X., Kankare V., Yu X., Hyyppä J., Holopainen M. 2013. Automated stem curve measurement using terrestrial laser scanning. *IEEE Transactions on Geoscience and Remote Sensing*, 52(3), 1739–1748.
- Liang X., Hyyppä J., Kaartinen H., Lehtomäki M., Pyörälä J., Pfeifer N., Huang H. 2018. International benchmarking of terrestrial laser scanning approaches for forest inventories. *ISPRS Journal of Photogrammetry and Remote Sensing*, 144: 137–179.
- Lovell J.L., Jupp D.L.B., Culvenor D.S., Coops N.C. 2003. Using airborne and ground-based ranging lidar to measure canopy structure in Australian forests. *Canadian Journal of Forest Research*, 29: 607–622, DOI: 10.5589/m03-026.
- Parker G.G., Harding D.J., Berger M.L. 2004. A portable LIDAR system for rapid determination of forest canopy structure. *Journal of Applied Ecology*, 41(4): 755–767.
- Pfeifer N., Gorte B., Winterhalder D. 2004. Automatic reconstruction of single trees from terrestrial laser scanner data. In *Proceedings of 20th ISPRS Congress*, 35: 114–119. Istanbul: ISPRS.
- Rusu R.B. 2013. *Semantic 3D object maps for everyday robot manipulation*. Springer.
- Schütt C., Aschoff T., Winterhalder D., Thies M., Kretschmer U., Spiecker H. 2004. Approaches for recognition of wood quality of standing trees based on terrestrial laserscanner data. *Laser-scanners for forest and landscape assessment. Proceedings of the ISPRS working group VIII/2, Freiburg, Germany. International Archives of Photogrammetry, Remote Sensing, and Spatial Information Sciences*, 36: 179–182.
- Simonse M., Aschoff T., Spiecker H., Thies M. 2003. Automatic determination of forest inventory parameters using terrestrial laserscanning: 252–258.
- Thies* M., Pfeifer N., Winterhalder D., Gorte B.G. 2004. Three-dimensional reconstruction of stems for assessment of taper, sweep and lean based on laser scanning of standing trees. *Scandinavian Journal of Forest Research*, 19(6): 571–581.
- Watt P.J., Donoghue D.N.M. 2005. Measuring forest structure with terrestrial laser scanning. *International Journal of Remote Sensing*, 26(7): 1437–1446.
- Yu X., Liang X., Hyyppä J., Kankare V., Vastaranta M., Holopainen M. 2013. Stem biomass estimation based on stem reconstruction from terrestrial laser scanning point clouds. *Remote Sensing Letters*, 4(4): 344–353.

11. Determination of selected stand characteristics with analysis of their changes in 2015–2019 using multi-temporal terrestrial laser scanning data

Kamil Kędra

Forest Research Institute, Department of Geomatics, Sękocin Stary, 3 Braci Leśnej St., 05-090 Raszyn
k.kedra@ibles.waw.pl

Abstract

The use of terrestrial laser scanning (TLS) data in this project aimed to test whether a point cloud acquired at a single position can be used to analyse spatial changes in temperate forest stands. Terrestrial laser scanning data collected from the same monitoring plots in 2015, 2017 and 2019 were used for the study.

The terrestrial laser scanning data were processed to extract various spatial statistics from them. The spatial statistics were in turn used to build predictive models for the basal area (BA), a number of trees (N) and volume (V). The models were then applied to the three datasets, allowing an analysis of the magnitude and direction of change on the analysed plots.

Thanks to the method used of analysing TLS data obtained from a single laser scan of the entire sample plot (without recording individual trees), qualitatively acceptable models were created for the basic stand characteristics: BA , N and V . This first attempt to apply such models for predicting changes in stand characteristics in two- and four-year periods confirmed the possibility of predicting the trend of changes in stand characteristics, especially in the long term and based on the compensation principle (the error of predicting changes did not exceed the actual magnitude of changes). The presented use of terrestrial laser scanning data requires further research and development of analytical methods for TLS point cloud analysis.

Keywords: multi-temporal analysis, basal area, number of trees, volume

11.1. Introduction

Current methods for using terrestrial laser scanning (TLS) to determine the structural attributes of a forest at the scale of a sample plot are limited to two major groups of methods. Attributes of the first type (a), based on statistical analysis of the distribution of TLS cloud points, include statistics on height distribution and TLS point density (Gobakken & Næsset 2008; Næsset 2004; Nilsson 1996), and variables related to the so-called ‘gap probability’ (vertical gap probability) (Lovell et al. 2011), through which a vertical vegetation profile can

be obtained that describes the vegetation area per unit volume (Plant Area Volume Density, PAVD) as a function of elevation (Calders et al. 2014). The second group of methods (b) is primarily concerned with geometric modelling. Variables describing forest structure are obtained more indirectly than in the case of (a), namely not from the TLS cloud points themselves, but from the geometric model created using the TLS point cloud. Although there are numerous studies on geometric modelling from TLS data (Calders et al. 2020; Newnham et al. 2015), only a small proportion of them explicitly address modelling at the sample plot level (Annighöfer et al. 2019; Ehbrecht et al. 2017; Willim et al. 2019).

Under the ForBioSensing project (Kędra et al. 2020a–c), researchers implemented a method for geometric modelling from TLS data at the scale of a sample plot (here, $500 \text{ m}^2 = 5 \text{ ares} = 0.05 \text{ hectares}$); previously used to identify the irregularity of vegetation distribution in the lower storeys of a stand (indicate complexity) (Willim et al. 2019); and to identify the intensity of neighbour competition in relation to the young trees analysed (Annighöfer et al. 2019). In general, the method consists of circumscribing a polygon on a “flattened” TLS point cloud layer (a cut-out point cloud layer containing the breast height (1.3 m), with the Z-values of the point heights zeroed out). Then, the basic measures of the polygon thus obtained were calculated: area and perimeter, which were then used to determine the polygon’s complexity index (McGarigal & Marks 1995). This method is based on a number of previous papers, in particular, the method proposed by Ehbrecht et al. (2017), where the complexity index was calculated from vertical profiles of the TLS point cloud. It is worth noting that this method does not require the location or size of individual trees to be determined; unlike geometric methods based on the scale of a single tree (Calders et al. 2020; Newnham et al. 2015), where (indirect) assessment at the scale of a sample plot involves summing the values obtained for individual trees.

The modifications of the approximation method aimed at adapting it to the description of the main stand structure in terms of three characteristics: basal area (area at breast height, BA , m^2), “numerical” (number of trunks, N , pcs) and volume (V , m^3). It has been shown (Kędra et al. 2020a–c) that after filtering the vertices of the basal polygon (in relation to breast height) according to the variation of the location of the analogous polygon corner points in the vertical gradient and expanding the number of variables describing the shape and size of the polygons, it is possible to obtain polygon characteristics that correlate significantly with the above-mentioned main stand traits, at the level of $r > 0.6$ (Kędra et al. 2020a–b).

This chapter reports the results of developing and applying selected empirical models for prediction of BA , N and V with the variables of TLS (Kędra et al. 2020a–b) to determine structural changes on sample plots established in the stands of the Polish part of the Białowieża Forest.

11.2. Materials and Methods

11.2.1. Study area and the stand characteristics analysed

The measurements were carried out on 94 fixed circular sample plots with a radius of 12.62 m (area $S_a = 500 \text{ m}^2$). The sample plots were distributed in the area of the Polish part of the Białowieża Forest, except for the area of the Białowieża National Park (BNP). The sample plots varied in terms of tree species composition: from plots with a clear dominance of a single species to mixed plots with variable proportions of individual species. In terms of tree number, sample plots with pine, spruce or oak as the dominant species in the stand were dominated; the age of the dominant stand ranged from 30 years to 250 years (median=100 years) (Fig. 11.1; according to the expert assessment carried out as part of the ForBioSensing project). Measurements on permanent sample plots were carried out in 2015, 2017 and 2019; a detailed description of the measurements can be found in the report of the ForBioSensing project (Paluch & Kuberski 2020). For this study, measurements on living or dead trees with diameter at breast height diameter of 7 cm or more were used, including stems broken above a height of 2.5 m above the ground. Measurements of individual trees were used to calculate three stand characteristics: basal area (BA, $\text{m}^2 \text{ 0,05}^{-1} \text{ ha}^{-1}$), number of trees (N, $\text{N } 0,05^{-1} \text{ ha}^{-1}$) and volume (V, $\text{m}^3 \text{ 0,05}^{-1} \text{ ha}^{-1}$). Table 11.1 provides a summary of these characteristics, for the three measurement periods.

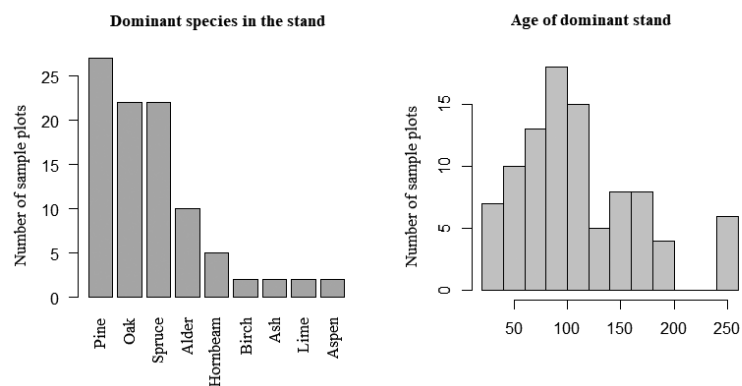

Figure 11.1. Number of sample plots by dominant species and histogram of the dominant stand age; according to expert assessment carried out for the ForBioSensing project

Table 11.1. Summary values of stand characteristics: basal area (BA, m^2), volume (V, m^3) and number of trees (N, pcs), for 94 sample plots (total area equal to 4.7 ha), in three measurement periods (2015, 2017 and 2019)

	2015	2017	2019
$\Sigma \text{BA (m}^2\text{)}$	170.9	169.8	164.9
$\Sigma \text{V (m}^3\text{)}$	2233.5	2229.7	2167.2
$\Sigma \text{N (n)}$	3087	3010	2929

11.2.2. TLS measurements

The first measurements were made between 26 July and 6 August 2015, with a Trimble TX5 phase scanner (resolution about 6 mm at 10 m). Further TLS measurements were made in 2017 and 2019, also during the growing season. A single TLS scan was taken from the centre of each of the 94 sample plots. The TLS data have been lightly processed: they were pre-filtered using the software FARO Scene and generalised with a 1 cm voxel grid to standardise the resolution of the point clouds over the entire sample plot area. The resulting TLS point clouds formed the basis for determining the TLS variables. For the 2015 and 2017 measurement periods, the entire set of 94 TLS scans was used; however, for the 2019 period, one sample plot was excluded from the analysis (due to lush vegetation).

11.2.3. Parameters adopted for the calculation of the shape indices and description of the variables

To obtain TLS data that could potentially explain the variations in included stand characteristics, a number of modifications were made to the previously used geometric TLS point cloud modelling methods at the sample plot level (Tab.11.2). Polygons were described on selected points from laser scanning that were furthest from the centre of the sample plot, within specific slices (Fig. 11.2). Four variants for the angular resolution of the polygons (centre angle of a single slice) were considered. The size of the angle and at the same time the number of slices affect the number of missed cloud points, the complexity of the resulting polygon and the computational requirements. A basic resolution (1°), two finer subdivisions (0.2° and 0.5°) and a variant with lower angular resolution (2°) were tested. Sets of several

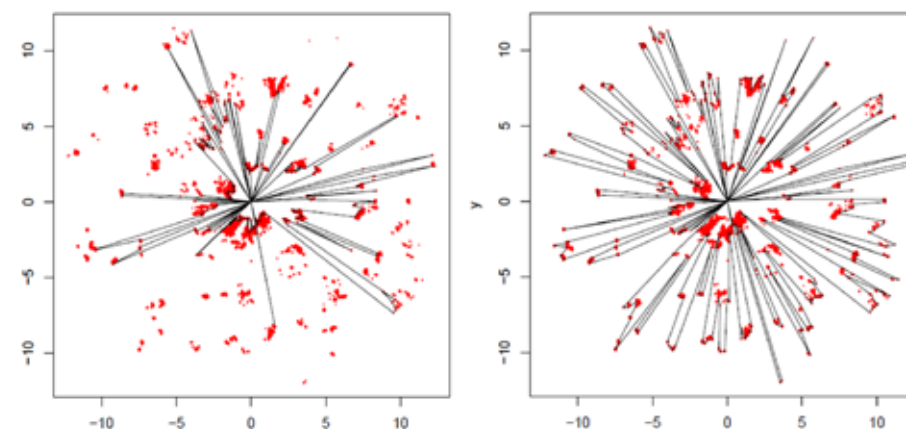

Figure 11.2. Two ways to describe the polygon on the (same) point cloud layer; left: vertices of the polygon are selected points from the laser scan, within 1-degree slices closest to the centre of the centre of the sample plot (similar to Willim et al. 2019); right: vertices of the polygon are selected points from the laser scan, within 1-degree slices furthest from the centre of the sample plot (similar to Annighöfer et al. 2019)

horizontal point cloud layers (Kędra et al. 2020a-c) were used to determine the shape indices, allowing for the vertical height gradient (up to 5.85 m above the ground). Finally, the best results were obtained for a set of three point cloud layers that ranged up to a height of 2.35 m (L1: points with heights between 1.25 m and 1.35 m; L2: points with heights between 1.75 m and 1.85 m; L3: points with heights between 2.25 m and 2.35 m). A new method was used to filter points belonging to the polygon described on the points of the base layer (with a height equal to the diameter at breast height), based on the coefficient of variation of the position of the points in the vertical gradient belonging to different layers but to the same section of the sample area. The coordinates of the vertices of the base polygon located within the slices for which the coefficient of variation of the distance between the vertices of the three polygons considered exceeded an empirically determined threshold ($CV = 0.035$) were set to zero (Fig. 11.3); in this way, „stable” points were distinguished that presumably describe tree trunks..

There are three types of surfaces that make up the total size of the sample area (Fig. 11.3): (a) the „effective” scanning area - the area penetrated by the laser beam before it encountered the scanned object; (b) the „free” area - the area where the scanning beam did not encounter any object (or where the points of the base polygon were erased in the filtering phase of CV); (c) the „occluded” area, which is equal to the size of the sample area (500 m^2) minus the combined size of areas (a) and (b). The range of variation measures for the size and shape of the resulting polygons was greatly expanded. The set of variables analysed ranged from the simplest measures such as area size and polygon perimeter (obtained using the „pracma” package in R (Borchers, 2019)) to more complex shape indices such as the „perimeter area index” (PAR) (Lovejoy 1982; Mandelbrot 1977) and the shape index (SHPI) (Patton, 1975) to as yet unpublished indices derived from the combination of two or more simpler measures (Kędra et al. 2020a-b). A total of 92 TLS variables were tested (23 shape indices \times 4 angular resolutions). Finally, the best models for the three selected stand characteristics were formed by 11 TLS variables representing all four angular resolutions (Tab. 11.3). These variables can be divided into three groups: (A) variables for whole polygons; (B) variables for second-order polygons (parts of whole polygons); (C) variables using information on the variation of the location of polygon vertices.

point cloud base layer parameters	1.3 m \pm 50 cm (100 cm)	1.3 m \pm 70 cm, -100 cm	1,3 m \pm 5 cm (10 cm)
(170 cm)	1.3 m \pm 5 cm (10 cm)	1°(?)	0.2°, 0.5°, 1°, 2°
angular resolution	1°	1°(?)	0.2°, 0.5°, 1°, 2°
criterion for the selection of points as vertices of a polygon	minimum distance from the scanner	maximum distance from the scanner	maximum distance from the scanner
number of layers	1	1	3
filtration of the vertices of the base polygon	no	no	yes

Table 11.2 Comparison of the three methods resulting in TLS shape indices

source:	Willim et al. (2019)	Annighöfer et al. (2019)	Kędra et al. (2020a-c)
aim of geometric modelling	determination of the degree of irregularity of the vegetation distribution in the lower stand level (complexity index)	determination of the degree of intensity of neighbourhood competition in relation to the saplings analysed	description of the main stand structure in terms of BA, V and N
radius of circular plot	15 m	5 m	12.62 m
voxelisation	yes, 1 cm	no	yes, 1 cm

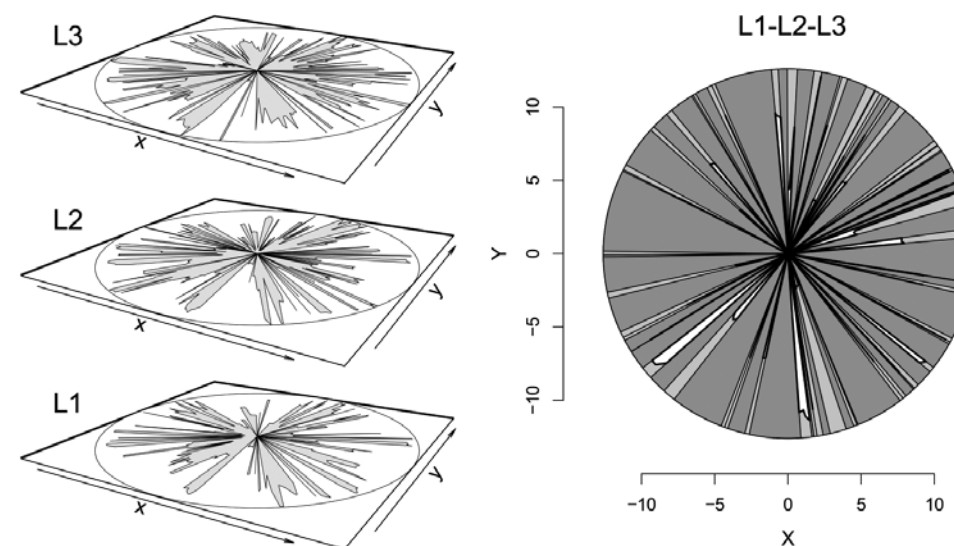

Figure 11.3. Example of three TLS point cloud layers considered (L1: points with height from 1.25 m to 1.35 m; L2: points with height from 1.75 m to 1.85 m; L3: points with height from 2.25 m to 2.35 m); L1-L2-L3: resulting polygon, after applying filtration of vertices of the base polygon (L1) - white colour (bold outline): „effective” scanning area - the area penetrated by the laser beams before they hit the scanned object; dark grey colour: „free” area - the area where the scanner beam did not hit any object (or where the points of the base polygon were filtered out in the filtering phase of CV); light grey: „occluded” area, equal to the size of the sample area (500 m^2) minus the combined size of areas (a) and (b)

Table 11.3. List of 12 variables (polygon size and shape indices) derived from the horizontal layers of the TLS point cloud; Type: A: whole-polygon variables, B: second-order polygon variables (parts of whole-polygons), C: variables using information about the variation in the location of the vertices of the polygons; angular resolution of the underlying polygon

Type	TLS variable	description	resolution (°)
A	AREA	polygon area (,pracma' package in R)	1.0
	SHPI1	polygon shape indicator (Patton, D. R. 1975)	0.2
	SHPI2		1.0
	SHPI3		2.0
B	Npoly		number of second-order polygons
	meanNpoints	average number of points of second-order polygons	2.0
	Nclear	number of areas where no objects were detected by the laser beam	0.2
	Cmax	the area of the largest (distinct) area in which the laser beams did not detect any objects	1.0
C	CV_RLE1	coefficient of variation of the distances of the individual points of the polygon from the centre pp, assuming 1-m distance intervals	2.0
	CV_RLE2	coefficient of variation of the number of returns of the unique distances of the points of a polygon from the centre pp, assuming 1-m distance intervals	1.0
	AREA_RLE2	polygon area (AREA), weighted by the coefficient of variation (CV_RLE2) of the locations of the individual points of the polygon	1.0
	AREA_PER_RLE2	polygon area per unique location of the points composing the polygon, weighted by the coefficient of variation (CV_RLE2)	1.0

11.2.4. Analysis of the suitability of TLS indices for predicting changes in BA (m²), N (pcs) and V (m³), at the sample plot scale

The best models for stand properties (for 2015 measurements), obtained using a semi-automated linear modelling and selection procedure taking into account interactions between the TLS explanatory variables (Kędra et al. 2020a-b), were used to predict structural changes in the stands of the Białowieża Forest (2015–2017–2019) within the studied sample plots. For both basal area (BA15) and volume (V15), the included interactions between TLS variables significantly improved the model [1, 2], while for tree number (N15) a simple linear model without interactions remained the best model [3]. In the leave-one-out cross-validation, the model determination coefficients were close to or above the $R^2=0.5$. $R^2_{BA15}=0.49$; $R^2_{V15}=0.51$; $R^2_{N15}=0.78$). In terms of prediction percentage error (%RMSE), values ranged from 22.1% for N15, through 23.4% for BA15, to 31.5% for V15 (Kędra et al. 2020a-b). In terms of prediction percentage error (%RMSE), values ranged from 22.1% for N15, through 23.4% for BA15, to 31.5% for V15 (Kędra et al. 2020a-b).

$$[1] \quad BA15 \sim AREA_RLE2 \times SHPI1 + Cmax \times SHPI4$$

$$[2] \quad V15 \sim AREA_PER_RLE2 \times AREA + AREA_PER_RLE2 \times Nclear + meanNpoints$$

$$[3] \quad N15 \sim Npoly + CV_RLE1 + SHPI3$$

The relationships between stand characteristics and individual TLS shape indices (2015 measurement) were analysed using Pearson's correlation coefficient, which determines the intensity and direction of the linear relationship between two variables. The variability of individual TLS shape indices, over the years (2015–2017–2019), was analysed using statistics: mean value (\bar{x}) and coefficient of variation (cv); the range of changes in TLS indices, between the outlying measurement periods (2015 and 2019), was also determined. The evaluation of the prediction of the values of stand characteristics in the 2017 and 2019 periods, using models parameterised from the 2015 measurement data, was carried out in two stages: (1) analysis of prediction quality using standard evaluation measures: root mean square error (RMSE), percentage of this error, relative to the mean value of the measurement (%RMSE), percentage bias (%BIAS) and coefficient of determination (R -sq.); (2) prediction analysis of the balance of stand characteristics (summary value), using the percentage error, with respect to the value obtained from field measurements, at the beginning of the balance period in question (2015–2017, 2017–2019 and 2015–2019).

11.3. Results and Discussion

All TLS shape indices analysed showed a significant correlation with at least one stand characteristic (Tab. 11.4). Six of the twelve TLS variables analysed showed significant correlations with all three stand characteristics. TLS variables referring to whole polygons de-

scribed in a point cloud (type A) and/or to the distribution of individual polygon vertices (type C) were more likely to have significant correlations with basal area (*BA*) and volume (*V*), while type B indicators (referring to parts of polygons or second-order polygons) had the highest correlation coefficients with number of trees (*N*). This group also had the highest correlation value ($r=0.88$) between *N* and the number of second-order polygons (*Npoly*). This result confirms that filtering the vertices of the base polygon (with respect to a height of 1.3 m) led to the expected results, leaving mainly points belonging to individual tree trunks. Similarly, a high correlation value ($r=0.60$) was obtained for the relationship between *N* and the area of the whole polygon (*AREA*), which is the summed value of the area of the second-order polygons in the number *Npoly*. The variable *AREA* was the only TLS variable in group A that showed positive correlations with *BA* and *V* ($r=0.48$ and $r=0.35$, respectively). The other variables in this group, i.e. the shape indices describing the complexity (or irregularity) of the resulting polygon (in terms of three different angular resolutions: *SHPI1*, *SHPI3*, *SHPI4*), showed negative correlation coefficients with *BA* and *V* (from $r=-0.17$ to $r=-0.46$, respectively). At the same time, a significant increase in correlation was observed with increasing angular resolution of the polygon (increasing number of vertices in the polygon), which could be related to a further increase in its complexity. It follows that sample plots with higher values of *BA* and *V* showed less irregularity in relation to *SHPI1* and *SHPI3*. However, the TLS variables that showed the strongest relationship with *BA* and *V* belonged to group C of the TLS indices, namely: *AREA_RLE2* and *AREA_PER_RLE2*. The variable *AREA_RLE2* is derived from the total size of the area of the polygon (*AREA*), while the variable *AREA_PER_RLE2* is derived from the averaged size of the area of the polygon, in terms of the number of classified groups of polygon vertices with similar distance from the centre of the sample plot area (probably describing the same tree trunk or tree trunks closer together). In addition, both variables contain a coefficient of variation related to the location of the individual polygon vertices (*CV_RLE2*), as a weight (multiplier) of the mentioned plot sizes. The additional component of the variable *AREA_PER_RLE2* allowed a slightly higher correlation with *V* ($r=0.61$) than in the case of the variable *AREA_RLE2* ($r=0.59$); however, it also caused a significant decrease in the correlation with *BA* and even a change in the direction of the relationship with the feature *N*.

Table 11.4. A list of 12 variables (indices of size and shape of polygons) obtained from horizontal layers of the TLS point cloud; Type: A: variables for whole polygons, B: variables for second order polygons (parts of whole polygons), C: variables using information on variation in the location of polygon vertices; angular resolution of the underlying polygon; BA15corr, V15corr, N15corr: Pearson correlations of TLS variables with breast height area, volume and number of stems (respectively; 2015 survey data); bold: correlations significant at . 0.05; bold and underlined: correlations significant at the .001 level; light grey: non-significant correlations

Type	TLS variable	BA15corr	V15corr	N15corr
A	AREA	0.48	0.35	0.60
	SHPI1	-0.45	-0.46	0.10
	SHPI3	-0.35	-0.43	0.30
	SHPI4	-0.17	-0.21	0.15
B	Npoly	0.23	0.02	0.88
	meanNpoints	0.46	0.44	0.23
	Nclear	0.01	-0.18	0.77
	Cmax	-0.10	0.03	-0.45
C	CV_RLE1	0.34	0.24	0.33
	CV_RLE2	0.34	0.42	-0.19
	AREA_RLE2	0.65	0.59	0.38
	AREA_PER_RLE2	0.53	0.61	-0.18

Analysis of the variability of the TLS indices, over the period 2015–2017–2019 showed relatively stable patterns of coefficients of variation, within each measurement period (Tab. 11.5). With that said, the most recent period (2019) was characterised by slightly higher variability in most TLS indicators. Overall, the *CV* (2015 and 2017 measurements) attained values ranging from 8.09% (*meanNpoints* variable in 2017) to 44.90% (*Cmax* variable in 2015); while, for the 2019 measurements, the *CV* attained a maximum value of 53.79% (*AREA_RLE2* variable). Since, as already noted, this TLS variable is positively correlated with *BA* and *V*; it is reasonable to assume that the variability of these stand characteristics may also have been highest in the last measurement period. High *CV* values tended to be associated with a wide range of percentage changes in TLS indices between the 2015 and 2019 measurements. The widest ranges of variation (more than $\pm 100\%$) concerned two indices: the already mentioned *AREA_RLE2* and *Cmax* (area of greatest „clearance” between the sides of the TLS polygon). In the case of the latter indicator, the range of variation even exceeded $\pm 200\%$; which may suggest that this is a variable that is extremely „sensitive” to structural changes in the stand. A certain exception is the variable *Npoly*, which, despite a significant *CV* (up to 45.33%), was not characterised by an exceptionally wide range of changes 2015-2019 (between -67.0% and 87.9%).

Type	TLS variable	2015		2017		2019		minΔ	maxΔ	minΔ [%]	maxΔ [%]
		\bar{x}	cv [%]	\bar{x}	cv [%]	\bar{x}	cv [%]				
A	AREA	20.23	39.03	20.45	42.01	18.84	47.11	-18.81	34.64	-93.0	171.2
	SHP11	57.18	34.28	56.54	32.79	58.27	36.59	-40.99	67.72	-71.7	118.4
	SHP13	36.70	25.00	36.59	26.63	36.98	31.85	-18.50	37.39	-50.4	101.9
	SHP14	28.17	22.86	26.92	23.92	27.39	25.64	-20.96	25.36	-74.4	90.0
	Npoly	23.89	39.89	23.46	41.55	21.95	45.33	-16.00	21.00	-67.0	87.9
B	meanNpoints	4.71	8.75	4.75	8.09	4.70	8.42	-1.67	1.91	-35.4	40.6
	Nclear	37.96	29.45	37.19	31.88	35.55	32.98	-17.00	33.00	-44.8	86.9
	Cmax	56.45	44.90	59.48	42.34	63.18	46.71	-131.98	115.25	-233.8	204.2
C	CV_RLE1	0.35	19.37	0.34	22.41	0.34	21.48	-0.12	0.25	-35.0	72.5
	CV_RLE2	0.69	27.70	0.68	25.40	0.68	26.49	-0.37	0.23	-53.2	33.9
	AREA_RLE2	13.77	43.06	13.82	43.82	12.89	53.79	-16.38	31.23	-118.9	226.7
	AREA_PER_RLE2	0.37	44.43	0.37	42.85	0.36	51.66	-0.28	0.38	-75.1	101.9

Table 11.5. Results of the analysis of the variability of the TLS indices, over the years (2015–2017–2019): \bar{x} : mean value; CV: coefficient of variation; minΔ and maxΔ: minimum and maximum change in the index, between measurements 2015 and 2019

Predictions of BA (m^2), V (m^3) and N (pcs), in 2017 and 2019, using models parameterised from measurements in 2015, revealed relative stability in the values of the coefficient of determination R -sq. (Fig. 11.4). However, there was a decreasing trend of R -sq. values for BA and N , in the order: base model (2015 fit), 2017 predictions, 2019 predictions. This may mean that changes over time in the stands of Białowieża Forest have caused the baseline models to become progressively outdated; and the quality of any predictions remains uncertain over time; however, further gradual deterioration in prediction quality is to be expected. During the analysed period, the R -sq. values, for these two characteristics were always higher than 0.5. Whereby, for 2019, N predictions (R -sq.=0.74) were significantly more accurate than BA predictions (R -sq.=0.51). The situation was different for model V; in this case, there was a clear reduction in R -sq. values, as early as the first prediction period (2017), followed by some increase in R -sq. values for the next prediction (2019). Nevertheless, the R -sq. values were both lower than 0.5 (0.35 for 2017 and 0.42 for 2019). For this reason, the suitability of model V, for the prediction of this characteristic in later years, based on TLS data, should be considered the lowest among the models analysed. In addition, the unclear trend of the R -sq. values for the 2017 and 2019 predictions, makes the quality of possible predictions of V in the later period, remain unknown.

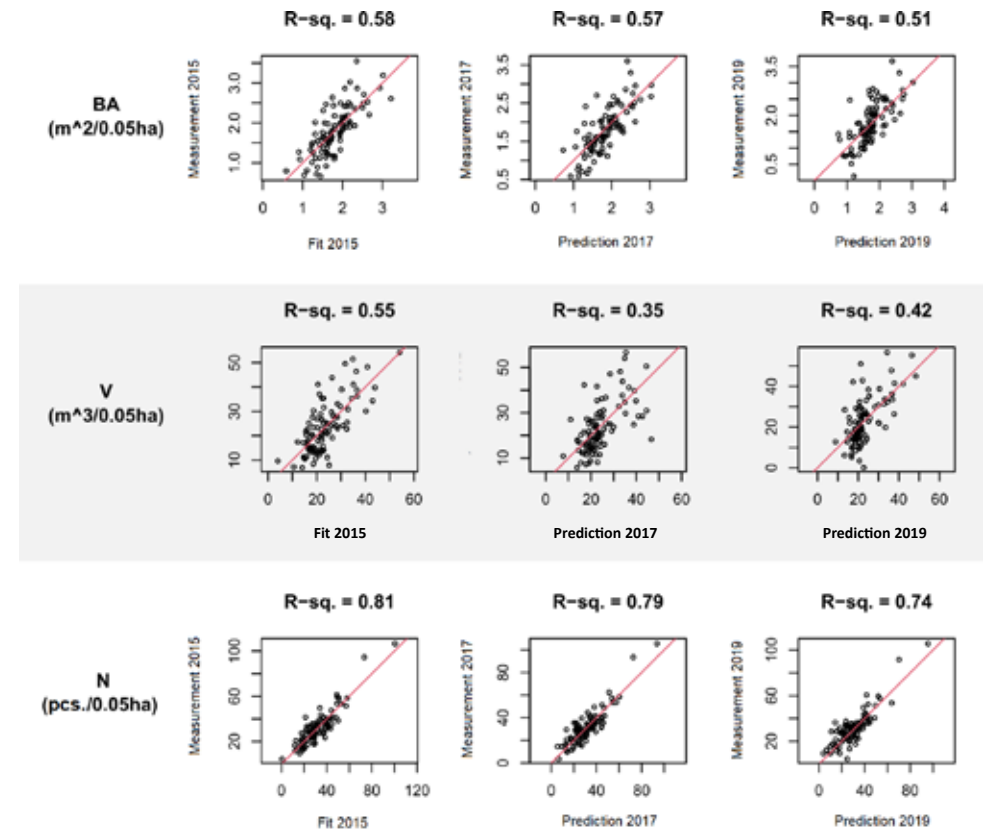

Figure 11.4. Scatter plots of points: fitted values or predictions (horizontal axis) against values obtained by field measurements (Measurement; vertical axis); for three stand characteristics: BA , V , N and for three periods: 2015, 2017 and 2019; the graph headings give the values of the coefficients of determination of the fit or prediction (R -sq.)

Tabela 11.6. Percentage balance results of three stand traits: BA, V and N, based on measurement (site-to-site) and prediction (model-to-site); percentage prediction error is given for the summed size of the characteristic at the beginning of the balancing period (2017–2015; 2019–2017; and 2019–2015)

percentage changes:	BA [%]	V [%]	N [%]
size of change 2017-2015 (field-field)	-0.61	-0.17	-2.49
size of change 2017-2015 (model-field)	1.21	2.77	-2.66
balance prediction error 2017-2015	1.82	2.94	0.16
size of change 2019-2017 (field-field)	-2.87	-2.76	-2.69
size of change 2019-2017 (model-field)	-3.69	-1.63	-6.69
balance prediction error 2019-2017	0.82	1.13	3.99
size of change 2019-2015 (field-field)	-3.35	-2.8	-5.09
size of change 2019-2015 (model-field)	-4.16	-1.67	-8.99
balance prediction error 2019-2015	0.81	1.13	3.89

The changes in the analysed stand characteristics reached up to about 5% during the period 2015–2019, and for each characteristic these changes were negative (Tab. 11.6): within the included sample plots, basal area decreased by 3.35%, volume decreased by 2.80%, and 5.09% of tree stems (alive or dead) were lost. Considering this relatively short period (four years), such changes should be considered noticeable; and, especially in the case of the number of trees, significant. Certainly, the negative trend of changes in all analysed characteristics is related to previous droughts, tree deaths and bark beetle outbreaks in the Białowieża Forest (Grodzki 2016; Nowakowska et al., 2020; Stereńczak et al. 2020). In the first (partial) accounting period (2015-2017), only for the number of trees was the trend of change correctly determined using the model, but with surprisingly high accuracy (site-to-site: -2.49%; model-to-site: -2.66%). The predicted inverse trend in the changes of BA and V (relative to actual) is probably related to the relatively low actual change in the summed values of these characteristics during this period (BA: -0.61%; V: -0.17%). In contrast, for both the second sub-period (2017–2019) and the four-year period (2015–2019), the change trends of all three characteristics were correctly predicted. Over the full measurement period, changes in terms of BA and N were overestimated ($BA_{(field-field)} = -3.35\%$ vs. $BA_{(model-field)} = -4.16\%$; $N_{(field-field)} = -5.09\%$ vs. $N_{(model-field)} = -8.99\%$). In contrast, the predicted changes in V were underestimated ($V_{(field-field)} = -2.80\%$ vs. $V_{(model-field)} = -1.67\%$). The total prediction errors of the balance of the studied characteristics using linear regression models from TLS variables did not exceed 4% of the total value of the characteristic at the beginning of the accounting period (2015) and did not exceed the magnitude of the actual change in any of the periods considered. These good results are certainly associated with the low bias of the models.

11.4. Conclusion

With the TLS data analysis method (Tab. 11.7) it is possible to obtain qualitatively acceptable models of the basic stand characteristics at the sample plot level from a single laser scan (without recording individual trees): BA, V and N (Kędra et al. 2020a-b). The TLS data used for the analysis refer to stands with different species and age structure (Fig. 11.1), which are in leaf-on condition. The quality of the prediction of stand characteristics in possible further time periods remains uncertain due to the observed deterioration or instability of the prediction quality in time periods that are further and further away from the baseline measurement (model parameterisation). To minimise this limitation, recalibration of the model or further work aimed at obtaining more stable models of stand characteristics from TLS data (size and shape indices of polygons based on horizontal TLS cloud layers, from a single laser scan).

Table 11.7. Summary of advantages and disadvantages of the TLS data analysis method used

Advantages	Disadvantages
<ul style="list-style-type: none"> - no need for multiple scans or for merging scans; - full automation (in R); - no need to segment (classify) TLS cloud points as different forest components; - simple and transparent method for obtaining TLS variables (small number of analysis steps); - low computational requirements; - medium to high correlations of the obtained TLS variables with stand characteristics (here: BA, V and N); - the possibility of predicting trends in changes in stand characteristics, especially over the long term and on a balancing basis; - the verification of the method in mixed stands with different structures in the leafed condition. 	<ul style="list-style-type: none"> - no resulting information on the location and distribution of the trees; - it is not possible to accurately determine the individual trees growth (measurement of the diameter at the breast height); - uncertainty about the quality of the prediction of stand characteristics in subsequent periods: need for recalibration of the model or further work aimed at obtaining more stable models of stand characteristics.

References

- Annighöfer P., Seidel D., Mölder A., & Ammer C. 2019. Advanced aboveground spatial analysis as proxy for the competitive environment affecting sapling development. *Frontiers in Plant Science*, 10(May), 1–12. <https://doi.org/10.3389/fpls.2019.00690>.
- Borchers H.W. 2019. *pracma: Practical Numerical Math Functions*. R package version 2.2.9. <https://cran.r-project.org/package=pracma>.
- Calders K., Adams J., Armston J., Bartholomeus H., Bauwens S., Bentley L. P., Chave J., Danson, F.M., Demol M., Disney M., Gaulton R., Krishna Moorthy S.M., Levic S.R., Saarinen N., Schaaf C., Stovall A., Terry L., Wilkes P., & Verbeeck H. 2020. Terrestrial laser scanning in forest ecology: Expanding the horizon. *Remote Sensing of Environment*, 251(April), 112102. <https://doi.org/10.1016/j.rse.2020.112102>.
- Calders K., Armston J., Newnham G., Herold M., & Goodwin N. 2014. Implications of sensor configuration and topography on vertical plant profiles derived from terrestrial LiDAR. *Agricultural and Forest Meteorology*, 194: 104–117. <https://doi.org/10.1016/j.agrformet.2014.03.022>.
- Ehbrecht M., Schall P., Ammer C., & Seidel D. 2017. Quantifying stand structural complexity and its relationship with forest management, tree species diversity and microclimate. *Agricultural and Forest Meteorology*, 242: 1–9. <https://doi.org/10.1016/j.agrformet.2017.04.012>.
- Gobakken T., & Næsset E. 2008. Assessing effects of laser point density, ground sampling intensity, and field sample plot size on biophysical stand properties derived from airborne laser scanner data. *Canadian Journal of Forest Research*, 38(5): 1095–1109. <https://doi.org/10.1139/X07-219>.
- Lovejoy S. 1982. Area-perimeter relation for rain and cloud areas. *Science*, 216(4542): 185–187. <https://doi.org/10.1126/science.216.4542.185>.
- Lovell J. L., Jupp D.L.B., Gorsel E. van, Jimenez-Berni J., Hopkinson C., Chasmer L., & van Gorsel E. 2011. Foliage profiles from ground based waveform and discrete point lidar. *Proceedings of SilviLaser 2011, 11th International Conference on LiDAR Applications for Assessing Forest Ecosystems*, University of Tasmania, Australia, 16–20 October 2011, 4(2006): 1–10.
- Mandelbrot B.B. 1977. *Fractals: Form, Chance, and Dimension*.
- McGarigal K., & Marks B.J. 1995. FRAGSTATS: spatial pattern analysis program for quantifying landscape structure. General Technical Report. PNW-GTR-351. <https://doi.org/10.2737/PNW-GTR-351>.
- Næsset E. 2004. Practical large-scale forest stand inventory using a small-footprint airborne scanning laser. *Scandinavian Journal of Forest Research*, 19(2): 164–179. <https://doi.org/10.1080/02827580310019257>.
- Newnham G.J., Armston J. D., Calders K., Disney M. I., Lovell J.L., Schaaf C.B., Strahler A.H., & Mark Danson F. 2015. Terrestrial laser scanning for plot-scale forest measurement. *Current Forestry Reports*, 1(4): 239–251. <https://doi.org/10.1007/s40725-015-0025-5>.
- Nilsson M. 1996. Estimation of tree heights and stand volume using an airborne lidar system. *Remote Sensing of Environment*, 56(1): 1–7. [https://doi.org/10.1016/0034-4257\(95\)00224-3](https://doi.org/10.1016/0034-4257(95)00224-3).
- Nowakowska J. A., Hsiang T., Patynek P., Stereńczak K., Olejarski I., & Oszako T. 2020. Health assessment and genetic structure of monumental Norway spruce trees during a bark beetle (*Ips typographus* L.) outbreak in the Białowieża Forest District, Poland. *Forests*, 11(6): 1–19. <https://doi.org/10.3390/f11060647>.
- Patton D.R. 1975. A diversity index for quantifying habitat “edge.” *Wildlife Society Bulletin*, 3(4): 171–173.
- Willim K., Stiers M., Annighöfer P., Ammer C., Ehbrecht M., Kabal M., Stillhard J., & Seidel D. 2019. Assessing understory complexity in beech-dominated forests (*Fagus sylvatica* L.) in central Europe—from managed to primary forests. *Sensors (Switzerland)*, 19(7). <https://doi.org/10.3390/f11060647>.

Reports, typescripts:

- Kędra K., Kamińska A., Kraszewski B., & Stereńczak K. 2020a. Porównanie predykcji wybranych zmiennych drzewostanowych z różnych zestawów danych skanowania laserowego. Raport z prac wykonanych w projekcie: Kompleksowy monitoring dynamiki drzewostanów Puszczy Białowieskiej z wykorzystaniem danych teledetekcyjnych (ForBioSensing).
- Kędra K., Kamińska A., Kraszewski B., & Stereńczak K. 2020b. Combining plot-level ALS and TLS metrics to predict key stand-structure variables in a temperate low-land complex mixed forest ecosystem. Manuscript in progress.
- Kędra K., Kraszewski B., & Stereńczak K. 2020c. Wskaźniki struktury drzewostanu uzyskane na podstawie danych z naziemnego skanowania laserowego (podtytuł: Wskaźniki kształtu TLS). Raport z prac wykonanych w projekcie: Kompleksowy monitoring dynamiki drzewostanów Puszczy Białowieskiej z wykorzystaniem danych teledetekcyjnych (ForBioSensing).
- Paluch R., & Kuberski Ł. 2020. Raport zawierający szczegółowy opis parametrów drzewostanów na naziemnych powierzchniach badawczych w roku 2015, 2017 i 2019 oraz analiza zmian. Raport z prac wykonanych w projekcie: Kompleksowy monitoring dynamiki drzewostanów Puszczy Białowieskiej z wykorzystaniem danych teledetekcyjnych (ForBioSensing).
- Wykonanie naziemnych pomiarów TLS i zdjęć hemisferycznych. Raport z prac wykonanych w projekcie: Kompleksowy monitoring dynamiki drzewostanów Puszczy Białowieskiej z wykorzystaniem danych teledetekcyjnych (ForBioSensing).

12. Tree species composition of the Białowieża Forest and its dynamics in the period 2015-2019

Aneta Modzelewska¹

¹ Forest Research Institute, Department of Geomatics, Sękocin Stary, 3 Braci Leśnej St., 05-090 Raszyn
a.modzelewska@ibles.waw.pl

Abstract

Tree species composition is one of the key variables necessary for effective forest management and planning of conservation activities. In recent years, an increasing number of studies have addressed the use of remote sensing data to determine species composition. The implementation of remote sensing allows the objectivisation of results and at the same time allows information to be obtained for a large area. Some of the more useful types of data are hyperspectral images. Their high informativeness combined with the use of machine learning algorithms enables the classification of individual tree species. The present study undertook to determine the species composition of Białowieża Forest using airborne hyperspectral imagery acquired three times in 2015 and 2017 and 2019 to assess the dynamics of change. The locations of the trees on ground plots were used as reference data. The classification included the following tree species: spruce (*Picea abies* (L.) H.Karst), pine (*Pinus sylvestris* L.), birch (*Betula pendula* Roth), oak (*Quercus robur* L.), hornbeam (*Carpinus betulus* L.), linden (*Tilia cordata* Mill.), alder (*Alnus glutinosa* Gaertn.) and other deciduous species. The Support Vector Machine algorithm (Vapnik 1999) was used. Classification accuracy varied depending on the management strategy of the area, ranging from 77% overall accuracy for managed forests to 64% for strictly protected areas. Changes in species composition between 2015 and 2019 were analysed. The biggest change occurred in spruce, which saw its share fall by 10%.

Keywords: Species composition, tree species classification, hyperspectral data

12.1. Introduction

Managing an extensive forest area is challenging and requires precise knowledge of numerous stand characteristics. Key features include information on species composition, which is essential for effective forest management (Heinzel and Koch 2012; Jones et al. 2010), modelling of other stand characteristics (Orka et al. 2013; Vauhkonen et al. 2014) as well as planning conservation activities, including biodiversity conservation (Nagendra 2001). The traditional method of obtaining information on species composition is through field work, but this is costly, lengthy and labour intensive (Ghosh et al. 2014). Moreover, information obtained in the field for selected sample plots lacks the comprehensive and spatially continuous information that can be obtained with remote sensing data. Particularly in

diverse or protected areas and those with areas inaccessible to fieldwork, the use of remote sensing data can be a solution.

The occurrence of particular tree species is closely related to habitat conditions. Vast areas of the forest lie in the temperate climate zone with continental and maritime climate influences (Jędrzejewska and Jędrzejewski 1998). The structure of the subsoil consists of a mosaic of boulder clays, glacial sands and gravels, sandstone sands and gravels and river muds, peats and silts (Kmieciak and Kwiatkowski 2009), on which mainly fertile soils have developed, such as brown earths, black earths, bog, post-bog and gley-podzolic soils. The fertile habitats have favourable conditions for the development of forest communities with a predominance of deciduous trees. Almost half of Białowieża Forest is deciduous: oak-hornbeam, alder and riparian forests, as well as early successional complexes with birch (*Betula* spp.) and aspen (*Populus tremula* L.). Coniferous and mixed forests constitute 52% of BF stands (Jędrzejewska and Jędrzejewski 1998). Faliński (1986) listed as dominant species of oak (*Quercus robur* L. and *Quercus petraea* (Matt.) Liebl.), hornbeam (*Carpinus betulus* L.), spruce (*Picea abies* (L.) H.Karst) and pine (*Pinus sylvestris* L.), followed by alder (*Alnus glutinosa* (L.) Gaertn.), linden (*Tilia cordata* Mill.), maple (*Acer platanoides* L.), birches (*Betula pendula* Roth and *B. pubescens* Ehrh.) and ash (*Fraxinus excelsior* L.). Most of the species listed still dominate the area today, but as a result of various processes, the contribution of some (elm and ash) has significantly decreased or disappeared from the area.

Various processes, such as the emergence of pathogens or insect infestations, can cause changes in species composition. The result can be the mass dieback of trees of one or more species. This happened in Białowieża Forest with Scots elm disease and the decline of ash as a result of colonisation by *Hymenoscyphus fraxineus* (T. Kowalski) Baral, Queloz & Hosoya and spruce dieback caused by bark beetle *Ips typographus* (L.) gradation. Dieback of ash and elm took place in the years preceding the ForBioSensing project, as a result of which currently these species occur sporadically in Białowieża Forest as single trees in a small number of segments and were not taken into account in remote sensing analyses due to their presence being too rare. However, trees of these species have died in recent decades and many have not yet fallen over, as a result, dead deciduous trees are relatively abundant in the study area (Kaminska et al. 2018). The species composition has been particularly affected in recent years by the bark beetle, causing mass dieback of spruce trees, the creation of new gaps (on which succession occurs in the later stages), and the overturning of trees of other species, which previously surrounded the spruce stand and did not adapt to the new conditions.

The species composition of a forest stand is a product of natural factors occurring in a given area and subsequent anthropogenic transformations resulting, for example, from forest management. The Polish part of the Białowieża Forest is unique in this respect, as part of the area is excluded from management activities, being a national park with a strict protection area and numerous reserves in the managed part. Particular stand variables, eg. forest structure or tree species mixture patterns can differ significantly in forests subjected to different management regimes. Although tree species composition of the research area is complex, all the analysed species occur all over the area. Seven most common species were classified in this study.

Remote sensing allows for the mapping of species composition in the layer visible from the airborne level. Application of the method is particularly important in large areas where field studies would be drawn out, or that are under protection or inaccessible due to natural barriers. There are examples in the literature of studies successfully applying remote sensing data in tree species classification (e.g. Dalponte et al. 2012; Ghosh et al. 2014). The use of hyperspectral data allows more species to be classified and higher accuracies to be achieved than with multispectral data (Fassnacht et al. 2016). However, the numerous papers touching on this topic mostly propose solutions for small areas, focused on development of the method or technical aspects, while papers describing species classification for extensive and complex areas are rare (Fassnacht et al. 2016; Modzelewska et al. 2020). Such research was undertaken in this project, classifying approximately 62,000 hectares of dense forest area.

When surveying areas in temperate climates, where lighting conditions change throughout the year and there are numerous phenological changes in trees during the growing season, the timing of image acquisition is also an important consideration. The literature does not provide a clear solution, and some studies have attempted to compare different time periods or assess the applicability of multi-temporal data. Such comparisons have occurred more frequently for multispectral data (e.g. Mickelson et al. 1998; Key et al. 2001; Hill et al. 2010). According to Mickelson et al. (1998), data acquired in spring and autumn were found to be more useful than summer data. Conversely, in Wolter (1995), only the multi-temporal picture could be applied to species classification. In both cases the images used were from different years and the authors recognised the need to compare one-year data. Such a comparison has been made in several studies using airborne data (Key et al. 2001; Hill et al. 2010, Tagliabue et al. 2016). In two cases the October data gave the best results (Key et al. 2001; Hill et al. 2010). Combining data from several seasons improved results in one case (Hill et al. 2010) and not in another (Key et al. 2001). In the only available study comparing several hyperspectral datasets, the merging of these datasets significantly improved the classification result (Tagliabue et al. 2016). This project compares results from 3 datasets acquired in one year (July, August and October 2015) and the following years 2017 and 2019. Maps of the dominant species in BF were produced, and the proportion of each species and the changes that occurred were analysed.

12.2. Materials and Methods

12.2.1. Data

The project used HySpex airborne hyperspectral images (VNIR-1800 and SWIR-384). Images with 5 m spatial resolution (and 2 m in 2019) in the 400-2500 nm spectral range were acquired in 2015 (three times, in July, August and October), in August 2017 and in August/September 2019. The images were radiometrically calibrated, and geometrically and atmospherically corrected by the data provider.

The reference material was data from field measurement campaigns conducted during the growing season, 2015, 2017 and 2019. The locations of selected trees were compared

with high-resolution multispectral images and a crown height model. For each of the classified mosaic images covering a fragment of Białowieża Forest, a set of reference pixels representing selected tree species was selected: spruce, pine, birch, oak, hornbeam, linden, alder and other deciduous species.

12.2.2. Image classification

Tree species detection was performed based on image classification. Images were pre-processed beforehand, which consisted of masking pixels not covered by vegetation, combining individual stripes into mosaics (the entire study area was covered by 8 mosaics) and transforming images using the Minimum Noise Fraction (MNF) method, which aims to reduce the dimensions of the spectral space and condense relevant information in the initial bands of the newly created image (Green et al. 1998). The Support Vector Machine (SVM) method (Vapnik 1999) was used to classify tree species. SVM is a supervised, non-parametric classification based on machine learning principles. The algorithm has been used in comparative work and has repeatedly performed better than matched algorithms (Melgani and Bruzzone 2004; Dalponte et al. 2008; Heinzel and Koch 2012; Mountrakis et al. 2011). The RBF kernel is often used in species classification, which was also used in this study (used in Ghosh et al. 2014; Fassnacht et al. 2014). The classification process was implemented using the R language. Classification was performed iteratively 100 times for each classified image. The reference pixels were split each time in a 70/30 ratio (70% training pixels, 30% verification pixels). The final maps for the fragments of the area were combined into one covering the whole BF area (Fig. 12.2).

12.2.3. Use of multi-temporal data

The classification procedure described above was repeated for images acquired in July, August and October 2015 and for data acquired in 2017 and 2019. Based on data from several seasons of 2015, a final map was also produced as a result of voting with the following conditions. A pixel was assigned class *x* if class *x* occurred in 2 or 3 seasons in that pixel. When a pixel had different classes in each season - the August class was assigned (this was the date when the highest accuracies were recorded). At the same time, the introduction of multi-temporal data has made it possible to eliminate several types of errors resulting from the masking process (when too many pixels are masked out). As a result, if a pixel had a value of NA (no data) in October, and was previously classified as a deciduous tree, it may have been mistakenly classified as a dead tree - it was assigned a value from August. Similarly, when a pixel with an NA value in July, later classified as pine, was most likely mistakenly masked as a dead tree (pine stands can be spectrally similar to dead spruce) - the August value.

12.2.4. Classification results versus field data

The classification results of the remote sensing materials were compared with field measurement results. The obtained classification maps were compared with the coverage of the monitoring plots by the crowns of the analysed trees. A methodology for approximate crown determination was implemented (Wietecha et al. 2019). For each monitoring plot, the proportion of area covered by tree crowns was calculated by drawing a circle around the trunk location. The radius of the circle was calculated from the relationship between height and crown area, according to species-specific formulas (Wietecha et al. 2019; Modzelewska et al. 2020).

12.3. Results

12.3.1. Classification accuracy

In 2015, the overall classification accuracy of individual images varied locally and between seasons. Locally, classification accuracies ranging from 60% to 80% were achieved, with one exception - image 7 in early summer was classified with approximately 50% accuracy. The median classification accuracy fluctuated around 70% (Fig. 12.1). For most images, the highest score was obtained for late or early summer (differences within 10-15%). Only in image 7 is there a greater difference between early and late summer (> 20%) observed.

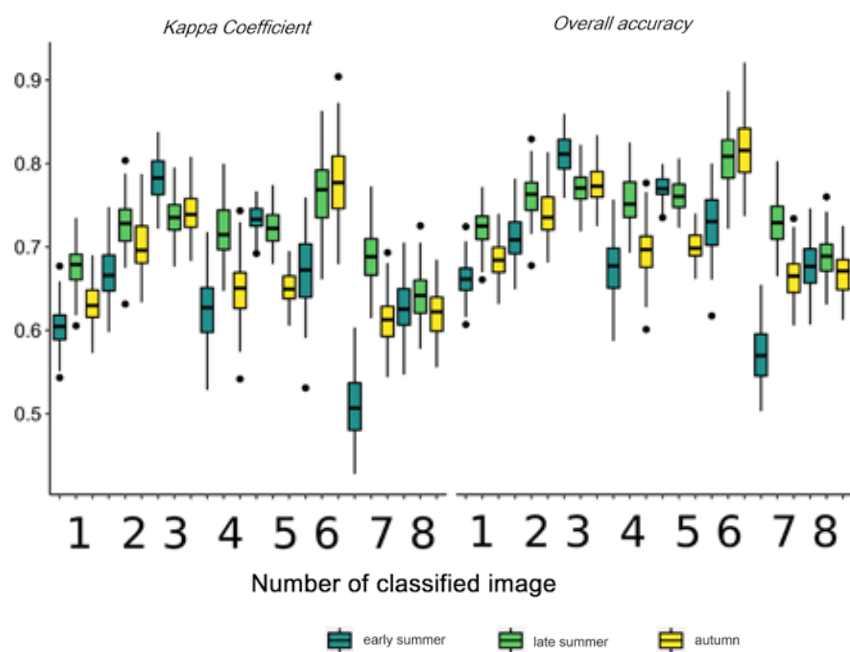

Figure 12.1. Accuracy of classification for individual fragments of the area

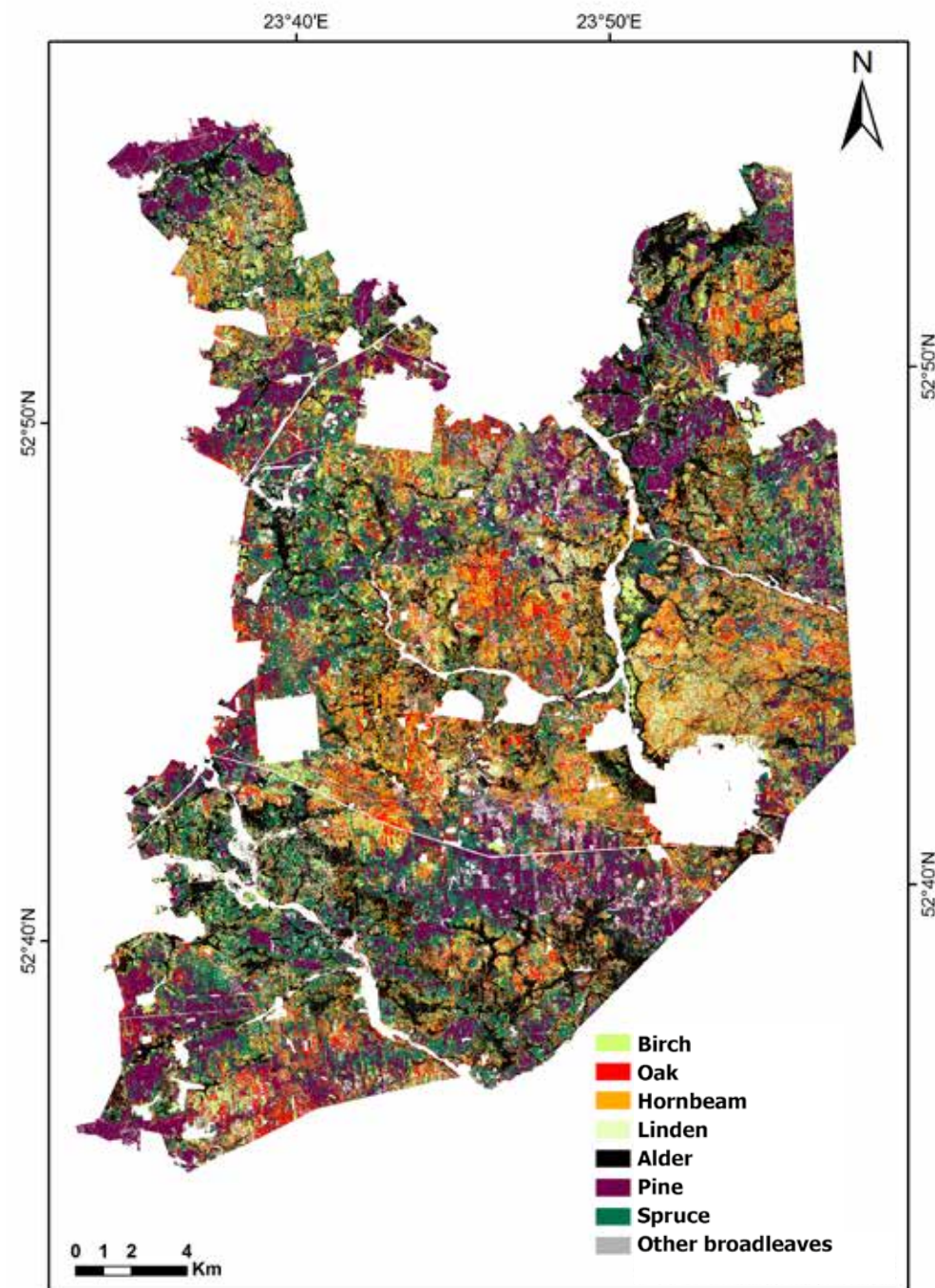

Figure 12.2. Map of dominant tree species in 2015 (Modzelewska et al. 2020, modified)

Classification accuracy varied for differently managed areas. While an accuracy of 77% was achieved for managed forests, it was only 66% for reserves and 64% for strict reserves.

The final result of the work performed in 2015 was a map (Fig. 12.2) based on three classification results from different seasons, using the voting method described in the subsection *Application of multi-temporal data*.

12.3.2. Species composition in differently managed areas (2015)

The analyses show the most common tree species in overstorey of the Polish part of Białowieża Forest are spruce, pine and alder. The proportion of each of the other deciduous species does not exceed 10% of the total study area. In commercial forests, pine and spruce have a significantly higher proportion than in protected areas. In the Strict Protected Area the reverse is true, here the proportion of coniferous species does not exceed 20% and deciduous species such as hornbeam and linden are gaining in prominence. In reserves outside the national park, we observe a high proportion of pine and the proportion of other broadleaved species is slightly higher than in managed forests (Fig. 12.3).

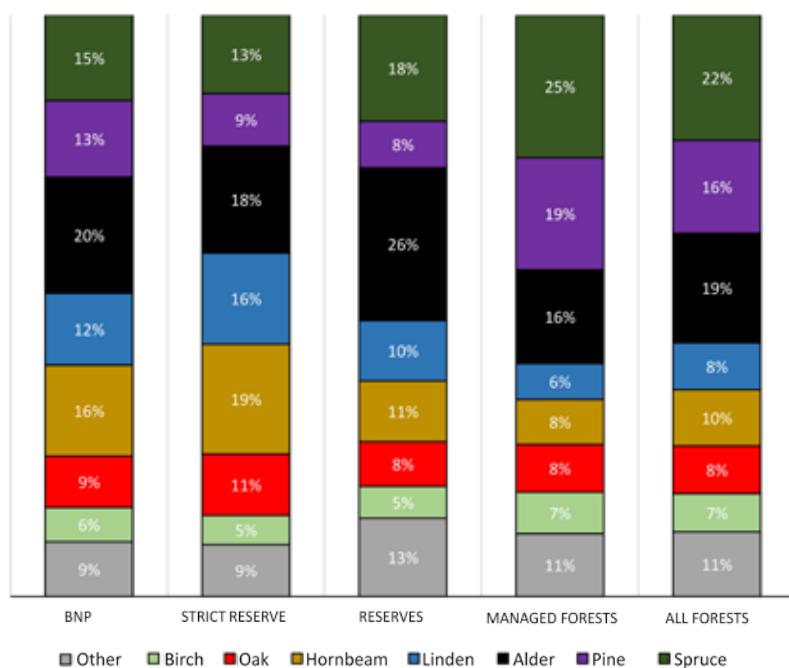

Figure 12.3. Proportion of individual dominant species (overstorey) in differently managed parts of BF

12.3.3. Changes in species composition between 2015 and 2019

The classification results of hyperspectral images acquired in 2015, 2017 and 2019 show some trends in changes in the species composition of Białowieża Forest. We observe a clear decrease in the proportion of spruce in 2019 compared to previous years and a slight decrease in the proportion of birch (Fig. 12.5).

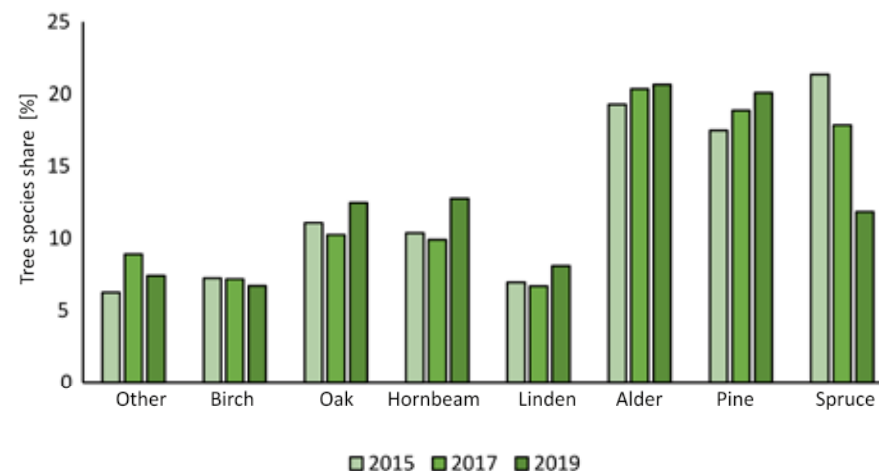

Figure 12.4. Changes in the proportion of each dominant species between 2015 and 2019

In the case of spruce, this decrease is not so significant in the results of ground measurements in the monitoring plots (Fig. 12.5). Among the other classified species, there is an increase in their proportion in the total area of the stands (Fig. 12.4). However, in the field plots, an increase in the proportion occurs only among oak and hornbeam, the other species are at the same level (linden) or show a slight decrease (pine, alder, others), as do the previously mentioned spruce and birch. We can assume that some discrepancies for some of the species are related to their overestimation and the corresponding underestimation of spruce in the 2019 species classification. There is no doubt that the proportion of spruce in Białowieża Forest has decreased as a result of gradation (Stereńczak et al. 2019). Most likely as a result of this process, we also observe an underestimation of the "spruce" class in the 2019 classification. As a result, there is also an overestimation of other species.

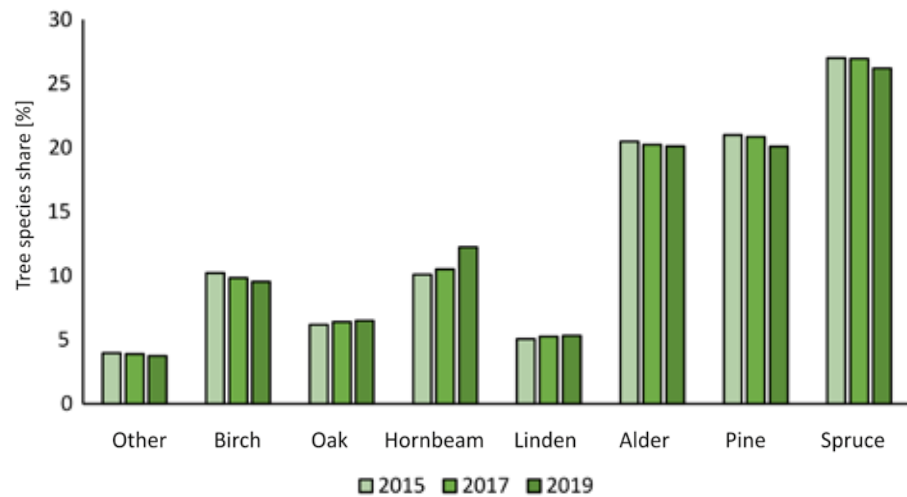

Figure 12.5. Changes in the proportion of individual dominant species on monitoring plots (field measurements)

12.3.4. Species structure - field data versus results of remote sensing analyses

The correctness of the identification of individual species within the monitoring plots varies depending on the management strategy of the forest area, as well as on the tree species themselves. For some species, e.g. pine, satisfactory results were obtained regardless of whether the plot was located in a managed forest or in a protected area. Spruce was better identified on plots in managed forest than in protected areas, while deciduous species were better identified on plots located within the boundaries of the Strict Protection Area. It can be caused by the size and shape of tree crowns - the crown of the spruce occupies less part of a pixel than the ones of the deciduous trees. Both for the study area as a whole and for the fragments with different management, congruence was high. The results of the research are described in detail in the article by Modzelewska et al. (2020).

12.3.5. Species structure based on hyperspectral data - changes between 2015 and 2019

In the results of remote sensing analyses, between 2015–2019, we observe a clear decrease in the proportion of spruce and a slight decrease in the proportion of birch in the Polish part of Białowieża Forest (in case of birch it can be partially the result of underestimation of the species). At the same time, there is an increase in the proportion of other species in the total area of stands (Fig. 12.4). The increase is particularly marked in pine, oak and hornbeam. It is also important to bear in mind the limitations associated with the classification of remotely sensed material - the accuracy of the overall classification ranged from 64% in the Strict Protection Area to 77% for managed forests. Metric characteristics of trees, such as height or crown area, also affect the likelihood of them being correctly classified. Especially

trees that are shorter and have a smaller crown area tend to be misclassified, but this tendency varies between tree species.

A clear decline in the proportion of spruce in Białowieża Forest as a consequence of the bark beetle gradation was evident as early as 2015. This process has continued in the following years of the project and, as a result, we can observe a decrease of several percent in 2017 compared to 2015 (Fig. 12.4). In the period 2017–2019, the decline was higher than in 2015–2017, and finally in 2019 a spruce proportion of about 12% was recorded. The value of the spruce share calculated from the hyperspectral images coincides with the result obtained from the classification of the independent dataset, i.e. airborne laser scanning.

12.3.6. Dynamics of selected tree species in the Białowieża Forest

Scots pine (*Pinus sylvestris* L.) appeared in the area of today's Białowieża Forest more than 10 thousand years ago, being one of the first species to enter this area after the Preboreal age. It belongs to the most numerous dominant species in Białowieża Forest. It occurs on the tops of moraine hills in the central part of the complex and in the south-western part of the Starzyna district, as well as near the watershed of the Hwoźna and Orłówka rivers in the area of Białowieża National Park. Pine forests also cover the area between the Hwoźna River and the village of Masiewo, between the villages of Masiewo and Gruszki, and the area of the Ładzka Forest in the north of BF. Pine is one of the primary species that forms part of the forest complexes growing in Białowieża Forest. Pine trees, especially in fertile habitats, can reach heights of over 40 m and a diameter at breast height of about 160 cm. They can live to the age of 350 years in the conditions of BF. More often than spruces, they are likely to reach their maximum age here (Faliński 1986).

In Białowieża Forest the phenomenon of pine dieback, common in other parts of the country, is not observed. From field observations, it appears that locally single individuals that have been weakened by the sudden change in light conditions are dying. This is the case with pines surrounded by spruces. When spruce trees die as a result of bark beetle gradation, conditions change for the pines growing among them. Also, trees attacked by the jewel beetle (*Phaenops cyanea*) are only locally present, no mass dieback is observed. This can be described as a marginal phenomenon, the death of individuals, but not of entire stands. An increase in the proportion of pine among the dominant species in the BF was observed between 2015 and 2019 (Fig. 12.6). Spatially - the proportion of pine trees in particular areas has practically not changed in recent years (Fig. 12.7).

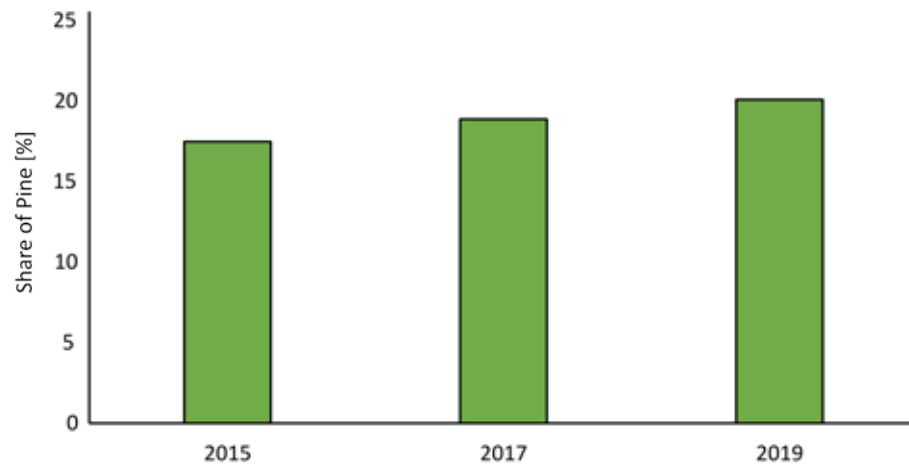

Figure 12.6. Changes in the proportion of pine trees in BF between 2015 and 2019

European hornbeam (*Carpinus betulus* L.) together with small-leaved linden (*Tilia cordata* Mill.), common oak (*Quercus robur* L.) and Norway maple (*Acer platanoides* L.) create one of the most common types of mixed forest in Białowieża Forest –oak-linden-hornbeam forest (*Tilio-carpinetum*). Individual hornbeams occur throughout the study area, but are most abundant in the fertile habitats of oak-linden-hornbeam forests. Trees of this species do not grow to such a size as maples or lindens. Individual specimens reach a height of up to 30 m and a diameter at breast height of up to 1 m (Faliński 1986).

Hornbeam is one of the species which regenerate and proliferate in Białowieża Forest in large numbers. No loss in its proportion was observed during the project, and it is present in large numbers in the youngest generation of regeneration. In 2015–2019 we observed an increase in the proportion of hornbeam among the dominant species in Białowieża Forest (Fig. 12.8). Spatially, we can observe a higher proportion of hornbeam in the districts, especially in the central part of the Białowieża Forest, in 2019 compared to 2015 and 2017 (Fig. 12.9).

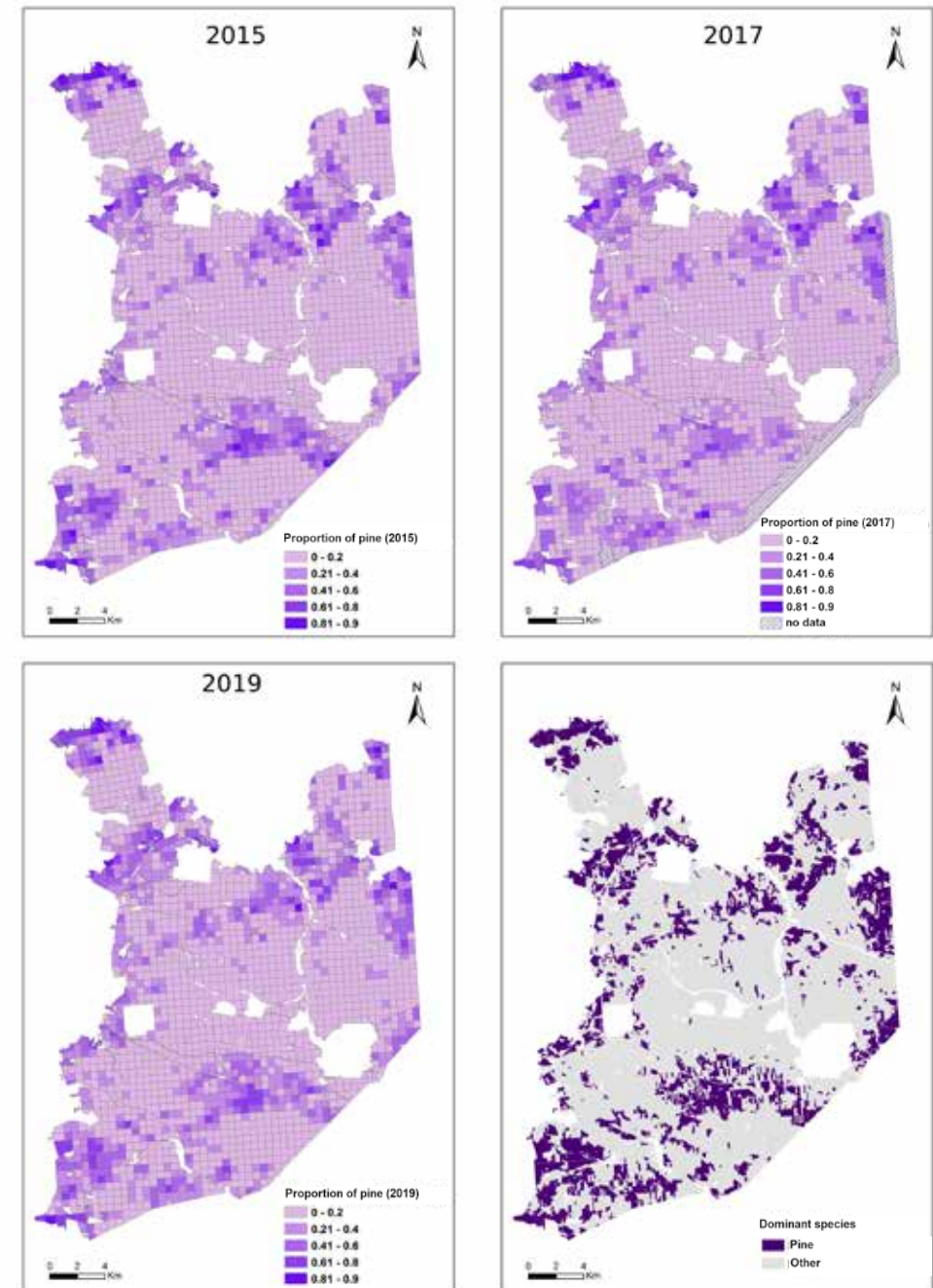

Figure 12.7. Spatial distribution of the proportion of pine trees in the study area in 2015–2019 and the sub-compartments with pine trees as the dominant species

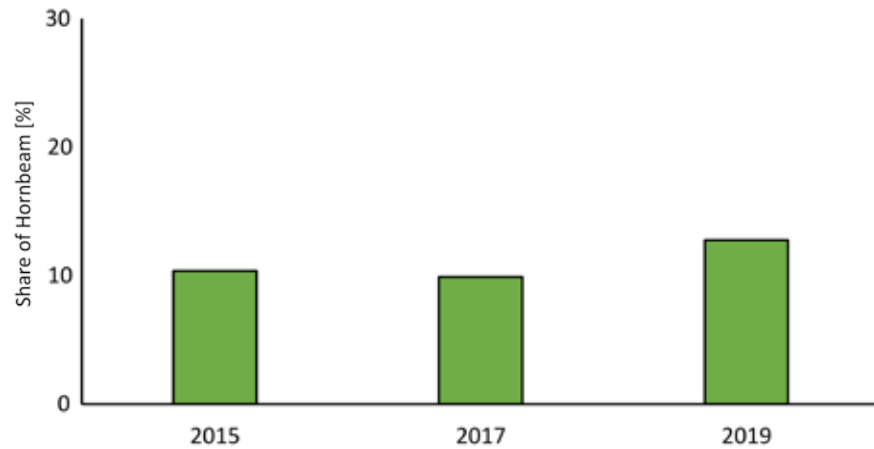

Figure 12.8. Change in the proportion of hornbeam in BF between 2015 and 2019

Norway spruce (*Picea abies* Karst.) was for years the most abundant species in Białowieża Forest, next to pine, and is the dominant species in a considerable part of forest segments in the study area. It has also been identified as the dominant species in numerous ForBioSensing monitoring plots. It is present across the whole of BF, less frequently in the Polish part of BNP and the part of BF administered by the Browsk Forest District than in other stands. According to Faliński (1968), spruce in BF was such a common species that there was practically no 1 sq. km of forest where spruce was not present. Currently, due to bark beetle gradation, which results in the mass dieback of trees of this species, the situation is changing. However, we can still find monumental trees of this species in BF. Some specimens reach impressive sizes - up to 40 m high (ForBioSensing field measurements).

Spruce is also subject to dynamic processes, above all, progressive bark beetle gradation since 2012, and the consequent dieback of trees. Standing dead trees fall over, which is observed even on a four-year cycle (the time between the first and last hyperspectral data acquisition in the ForBioSensing project), resulting in the creation of new gaps and the widening of existing ones. At the same time, in many places where spruce trees have died, spruce regeneration is appearing. However, the overall trend is a significant decline in the proportion of this species in BF stands. The share of spruce decreased significantly between 2015 and 2019 (Fig. 12.10). A similar trend can be observed in the maps showing the proportion of spruce in the segments – it decreased significantly, especially in the central part of the study area (Fig. 12.11).

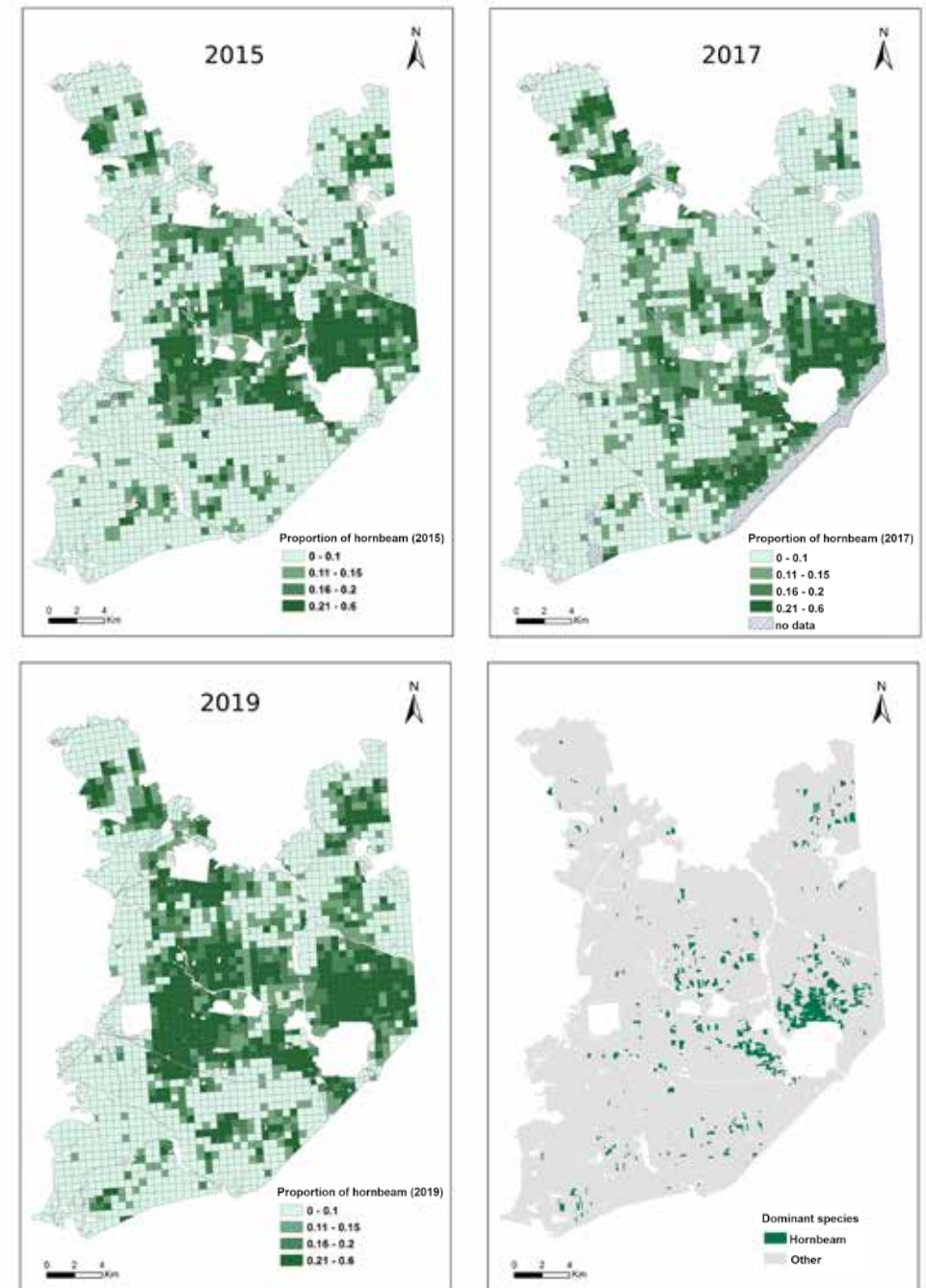

Figure 12.9. Spatial distribution of the proportion of hornbeam in BF in 2015–2019 and sub-compartments with hornbeam as the dominant species

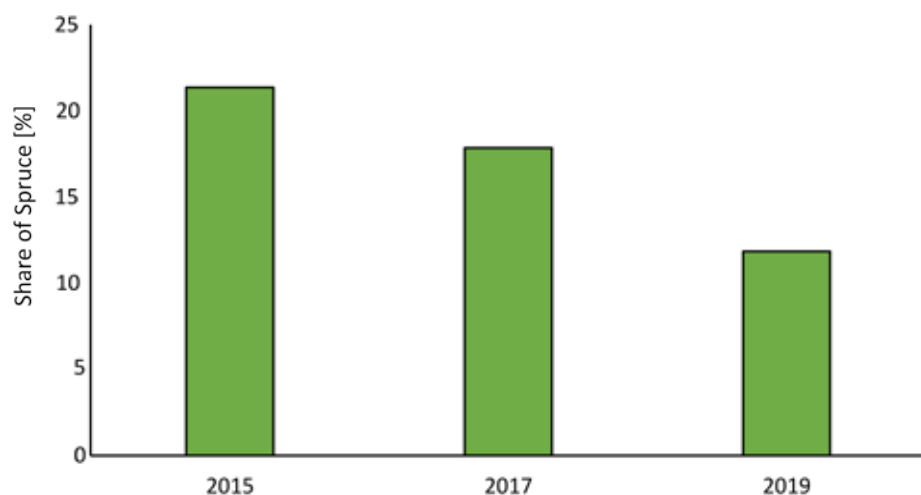

Figure 12.10. Changes in the proportion of spruce in BF between 2015 and 2019

European ash (*Fraxinus excelsior* L.) and Scots elm (*Ulmus glabra* Huds.) are species which were historically common in Białowieża Forest (Faliński 1986), but which are subject to mass dieback all over Europe as a result of colonisation by fungal pathogens. These are *Ophiostoma ulmi* (Buisman) Nannf., *Ophiostoma himal-ulmi* Brasier & Mehrotra and *Ophiostoma novo-ulmi* Brasier in the case of elm, the fungi causing graptiosis (Dutch elm disease) in elm and *Hymenoscyphus fraxineus* (T. Kowalski) Baral, Queloz & Hosoya which is the cause of European ash dieback.

European ash (*Fraxinus excelsior* L.) used to be one of the dominant tree species in Białowieża Forest (Faliński 1986), but this has changed following the mass dieback of this species. Ash dieback was observed in north-eastern Poland in the 1990s. In the 1970s, within a few years, it had spread to the whole of Poland and to numerous European countries (Bakys et al. 2009; Cholewińska et al. 2018). In the reserve part of Białowieża National Park (Strict Protection Area), the number of ash trees present decreased by 99.5% between 1990 and 2016 (Cholewińska et al. 2018). It is estimated that there is a similar disappearance of this species in the whole area of Białowieża Forest. In the ForBioSensing monitoring plots (685), of more than 8,000 trees with a visibility class of "1" (marked in the field as visible on aerial photographs), 92 ash trees were found (~0.01).

European ash is retreating from the BF area and it is currently estimated that the number of ash trees present is less than 1% of the trees in the BF. Due to its rare occurrence, this species is losing its prominence in BF. With such a small population, which is additionally dispersed throughout the BF area, and which does not form dense stands or at least larger clusters, the use of remote sensing data (with the spatial resolution of 5 m) is not possible. In order to verify this thesis, a classification test with the distinction of the class "ash" was carried out on the fragment of the study area characterised by the highest species diversity

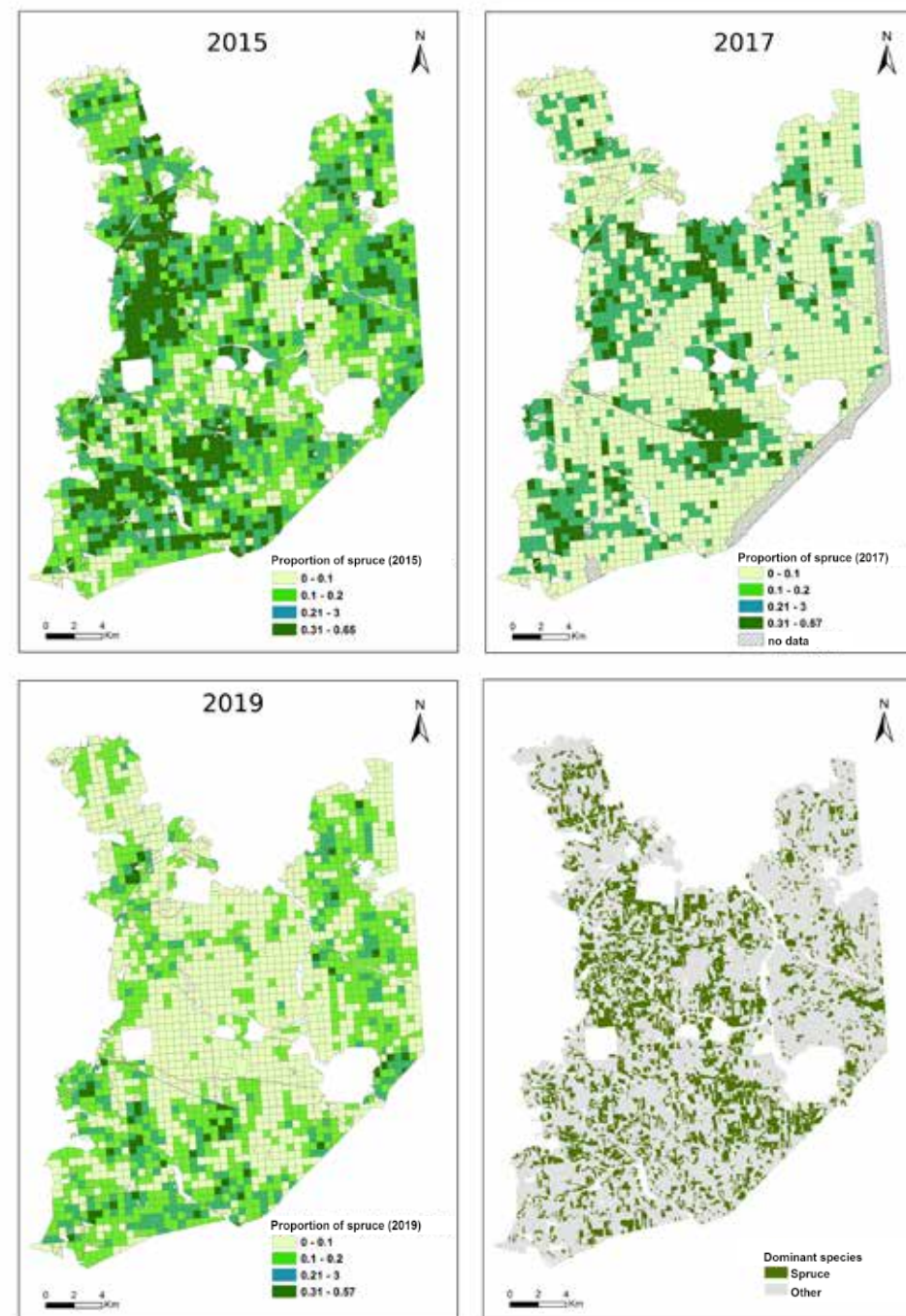

Figure 12.11. Spatial distribution of the proportion of spruce in BF in 2015–2019 and the sub-compartments with spruce as the dominant species

- Białowieża National Park. This experiment concluded that it was not possible to distinguish the class "ash". The median accuracies of the manufacturer and user for this class fluctuated around 0 whilst the overall accuracy was relatively high (>0.7) as was the accuracy of the other classes (>0.6). The most significant limiting factor is the small number of trees of this species in the study area with a scattering of individual specimens in BF stands.

In the case of Scots elm, no such experiment was carried out, as this species is almost extinct in the study area. In the ForBioSensing monitoring plots, 11 trees of this species were identified in visibility class "1".

12.4. Discussion

In the project, we addressed the issue of analysing species composition in a vast forest area, which is diverse in terms of use and protection, as well as in terms of structure, age, habitat and also ultimately, tree species. All these factors affect not only the species composition of the forest itself, but also the ability of studying it using remote techniques. Different forms of management and protection are reflected in the character of the forest and the diversity of vegetation it contains. The ForBioSensing project used aerial hyperspectral images acquired several times during the project. Of particular importance was the acquisition of data three times in 2015, which enabled an assessment of the impact of phenology on the ability to distinguish tree species using remote sensing data.

The project has achieved several milestones in the advancement of remote sensing research for forest areas. This is the first time such a vast and diverse forest area has been analysed. This was the first time hyperspectral data was acquired three times in one year and used to classify the dominant tree species in the forest. Tree species were classified three times in 2015, comparing results for different seasons. A final map was produced combining the results from different dates. The data was captured again in 2017 and 2019 and the results were collated together to compare changes. Seasonal changes were contrasted with differences in areas with different management.

The way in which the area is managed (forest management, protection) has an impact on the results of classification using remote sensing methods. In this particular area, forest stands under protection, especially strict reserve, are multi-layered stands with a considerable share of deciduous species. Those factors could influence the classification result. Protected areas were classified with about 10% lower accuracy than managed forest areas. The overall accuracy in protected areas was 64-66%, while in managed areas it was almost 80%.

The diversity of species in a tree stand also affects the differentiability of individual tree species. Trees growing in single-species forests (e.g. alder, pine) are classified with higher accuracy than species typical for mixed forests, e.g. oak-hornbeam forests. For spruce, we notice certain underestimation, which is more evident in protected areas due to their higher diversity, and spruces grow there singly (Faliński 1986), among deciduous trees that, with their extensive crowns, may dominate the pixels. Narrow crowns of spruce occupy a smaller area inside pixels than crowns of deciduous trees (Caudullo et al. 2016). This characteristic may explain the overestimation of deciduous trees in stands dominated by oaks, lindens or

hornbeams. Single coniferous trees are "invisible" when an entire pixel is assigned to a class corresponding to a deciduous tree. Both in the managed areas and in protected forests, alder is classified most efficiently. This may be caused by the structure of alder plots, where the portion of the dominant species (alder) is high, and that of codominant species, marginal. The mixing of species within alder forests is lower than in other deciduous tree stands (Faliński 1986). In the opposite case of oak-hornbeam forests, where mixing is high and dominant species, namely linden, hornbeam and oak have similar spectral characteristics. The two factors are likely to make the classification successful.

Relatively homogeneous managed stands are classified with higher accuracy than protected areas. This difference is approx. 10% for this study. A similar difference between less (Val di Sella, Italy) and more complex (Bosco della Fontana, Italy) research areas was observed by Dalponte et al. (2009). Studies describing results with very high accuracy (80–95%) were aimed to classify less complex managed forests (e.g. Fassnacht et al. 2014; Ghosh et al. 2014). However, the literature does not provide studies for areas managed heterogeneously, because such areas of a compact block of forest are rare. In this respect, the Białowieża Forest is unique. For this site, the species composition was established using remote sensing techniques for the first time in literature.

The results for different dates during the growing period show that summer is a much better time to acquire data than autumn. This is quite surprising as literature indicates that autumn, a season when discoloured trees differ the most, and in some comparative studies, it was the classification of data acquired in October that produced the best results (Key et al. 2001; Hill et al. 2010). However, when classification using hyperspectral data was compared, then data acquired in June (Tagliabue et al. 2016), July (Voss and Sugumaran 2008) or August (Richter et al. 2016) gave better results than those of autumn. In this case, the results for early and late summer are similar. However, we can unequivocally state that autumn is not a good time to acquire data. In autumn, shadows are longer and the amount of sunlit pixels is lower. This results in lower quality images taken in autumn. In addition, some trees may have already lost their leaves - 2015 was an exceptionally dry year in the study area (Boczoń et al. 2018; Łabędzki and Bąk 2015), and the presence of water stress can accelerate leaf senescence and leaf shedding by trees (Kim et al. 2016).

Work from the following years – 2017 and 2019 indicate the directions of changes that are taking place in the Białowieża Forest area. Above all, there is a clear decline in the proportion of spruce, as well as a decline in the proportion of birch. Among other species, the trend is the opposite – a slight increase in the proportion of the overall number. This trend is not always reflected in the results of field measurements, which may be due to the overestimation of deciduous species in the classification. At the same time, the share of spruce in Białowieża Forest decreased significantly as early as 2015 (Stereńczak et al. 2019), and gradation continued in the following years, so the share of this species gradually decreased in 2015–2019. The decline in the proportion of spruce, and the consequent significant number of dead trees, has consequences for the forest as a whole. Changing light conditions contribute to the deterioration of trees of other species growing in the vicinity, such as pines. Another consequence is the emergence and widening of gaps. Białowieża Forest is a forest with dynamic phenomena that cause its character and species composition to change.

12.5. Conclusion

The species composition of the Polish part of Białowieża Forest and its changes between 2015 and 2019 were analysed. A set of hyperspectral images and reference field data were successfully used. It was the first study of its kind for such an extensive area (over 60,000 hectares). The summer months of July and August were chosen as the optimal time for classification. In 2015, the highest accuracy of the study was obtained for data acquired in August (late summer). Dynamic processes occurring in the stands of the Białowieża Forest are reflected in its species composition and its changes. The most marked change is the decline in the proportion of spruce among the dominant species.

In summary, the following conclusions can be drawn:

1. Bark beetle gradation was the most important factor in shaping the composition of the species. As a result, the proportion of spruce has decreased from 22% in 2015 to 12% in 2019.
2. Pine increased its share slightly and its dieback has a classic uniform character and is not related to gradation effects.
3. Ash and elm, due to their mainly uniform mixing and low abundance, could not be included in the monitoring of dynamics using the available remote sensing data. Other high-resolution data could perhaps contribute to better detection of these species.
4. The area occupied by the following species: hornbeam, pine, oak, alder and linden increased, while for the other species it decreased.

References

- Boczoń A., Kowalska A., Ksepko M., Sokołowski K. 2018. Climate warming and drought in the Białowieża Forest from 1950-2015 and their impact on the dieback of Norway spruce stands. *Water (Switzerland)*, 10: 1–18. DOI: 10.3390/w10111502.
- Bakys R., Vasaitis R., Barklund P., Ihrmark K., Stenlid J. 2009. Investigations concerning the role of *Chalara fraxinea* in declining *Fraxinus excelsior*. *Plant Pathology*, 58: 284–292. DOI: 10.1111/j.1365-3059.2008.01977.x.
- Caudullo G., Tinner W., De Rigo D. 2016. *Picea abies* in Europe : distribution, habitat, usage and threats. *European Atlas of Forest Tree Species*: 114–116.
- Dalponte M., Bruzzone L., Gianelle D. 2012. Tree species classification in the Southern Alps based on the fusion of very high geometrical resolution multispectral/hyperspectral images and LiDAR data. *Remote Sensing of Environment*, 123: 258–270. <https://doi.org/10.1016/j.rse.2012.03.013>.
- Dalponte M., Bruzzone L., Gianelle D. 2008. Fusion of hyperspectral and LIDAR remote sensing data for classification of complex forest areas. *IEEE Transactions on Geoscience and Remote Sensing*, 46: 1416–1427. <https://doi.org/10.1109/TGRS.2008.916480>.
- Dalponte M., Bruzzone L., Vescovo L., Gianelle D. 2009. The role of spectral resolution and classifier complexity in the analysis of hyperspectral images of forest areas. *Remote Sensing of Environment*, 113: 2345–2355. <https://doi.org/10.1016/j.rse.2009.06.013>.
- Faliński J.B. 1986. Vegetation dynamics in temperate lowland primeval forests Ecological studies in Białowieża forest. *Ecological Studies in Białowieża Forest*; Junk Publishers: Dordrecht, The Netherlands.
- Fassnacht F.E., Latifi H., Stereńczak K., Modzelewska A., Lefsky M., Waser L.T., Straub C., Ghosh A. 2016a. Review of studies on tree species classification from remotely sensed data. *Remote Sensing of Environment*. <https://doi.org/10.1016/j.rse.2016.08.013>.
- Fassnacht F.E., Neumann C., Forster M., Buddenbaum H., Ghosh A., Clasen A., Joshi P.K., Koch B. 2014. Comparison of feature reduction algorithms for classifying tree species with hyperspectral data on three central european test sites. *IEEE Journal of Selected Topics in Applied Earth Observations and Remote Sensing*, 7: 2547–2561. <https://doi.org/10.1109/JSTARS.2014.2329390>.
- Ghosh A., Fassnacht F.E., Joshi P.K., Koch B. 2014. A framework for mapping tree species combining hyperspectral and LiDAR data: role of selected classifiers and sensor across three spatial scales. *International Journal of Applied Earth Observation and Geoinformation*, 26: 49–63. <https://doi.org/10.1016/j.jag.2013.05.017>.
- Goodenough D.G., Dyk A., Niemann K.O., Pearlman J.S., Chen H., Han T., Murdoch M., West C. 2003. Processing Hyperion and ALI for forest classification. *IEEE Transactions on Geoscience and Remote Sensing*, 41: 1321–1331. <https://doi.org/10.1109/TGRS.2003.813214>.
- Green A., Berman M., Switzer P., Craig M. A transformation for ordering multispectral data in terms of image quality with implications for noise removal. *IEEE Transactions on Geoscience and Remote Sensing*, 26: 65–74. <https://doi.org/10.1109/36.3001>.
- Heinzel J., Koch B. 2012. Investigating multiple data sources for tree species classification in temperate forest and use for single tree delineation. *International Journal of Applied Earth Observation and Geoinformation*, 18: 101–110. <https://doi.org/10.1016/j.jag.2012.01.025>.
- Jędrzejewska B., Jędrzejewski W. 1998. Predation in Vertebrate Communities. The Białowieża Primeval Forest as a Case Study. *Ecological Studies*. <https://doi.org/10.1007/978-3-662-35364-6>.
- Jones T.G., Coops N.C., Sharma T. 2010. Assessing the utility of airborne hyperspectral and LiDAR data for species distribution mapping in the coastal Pacific Northwest, Canada. *Remote Sensing of Environment*, 114: 2841–2852. <https://doi.org/10.1016/j.rse.2010.07.002>.
- Kamińska A., Lisiewicz M., Stereńczak K., Kraszewski B., Sadkowski R. 2018. Species-related single dead tree detection using multi-temporal ALS data and CIR imagery. *Remote Sensing of Environment*, 219: 31–43. <https://doi.org/10.1016/j.rse.2018.10.005>.
- Key T., Warner T.A., McGraw J.B., Fajvan M.A. 2001. A comparison of multispectral and multitemporal information in high spatial resolution imagery for classification of individual tree species in a temperate hardwood forest. *Remote Sensing of Environment*, 75: 100–112. [https://doi.org/10.1016/S0034-4257\(00\)00159-0](https://doi.org/10.1016/S0034-4257(00)00159-0).
- Kim J., Woo H.R.R., Nam H.G.G. 2016. Toward systems understanding of leaf senescence: an integrated multi-omics perspective on leaf senescence research. *Molecular Plant*, 9: 813–825. DOI: 10.1016/j.molp.2016.04.01.
- Kmieciak M., Kwiatkowski W. 2009. Szczegółowa Mapa Geologiczna Polski 1:50 000, arkusz Białowieża. Państwowy Instytut Geologiczny - PIB.

- Łabędzki L., Bąk B. 2015. Drought in Poland in 2015 and an assessment of impacts in permanent grassland. *Wiadomości Melioracyjne i Łąkarskie*, 3: 102–106.
- Melgani F., Bruzzone L. 2004. Estimation of biophysical parameters from optical remote-sensing images with high-order residues. [In:] *Geoscience and Remote Sensing Symposium, 2004. IGARSS' 04. Proceedings. 2004 IEEE International*. <https://doi.org/10.1109/IGARSS.2004.1368700>.
- Meyer D., Dimitriadou E., Hornik K., Weingessel A., Leisch F. 2019. e1071: Misc Functions of the Department of Statistics, Probability Theory Group (Formerly:E1071), TU Wien. R package version 1.7-0.1. <https://CRAN.R-project.org/package=e1071>.
- Modzelewska A., Fassnacht F.E., Stereńczak K. 2020. Tree species identification within an extensive forest area with diverse management regimes using airborne hyperspectral data. *International Journal of Applied Earth Observation*, 84, 101960. DOI: 10.1016/j.jag.2019.101960.
- Modzelewska A., Kamińska A., Fassnacht F.E., Stereńczak K. 2021. Multitemporal hyperspectral tree species classification in the Białowieża Forest World Heritage site, Forestry: An International Journal of Forest Research, 94(3): 464–476. DOI: 10.1093/forestry/cpaa048.
- Mountrakis G., Im J., Ogole C. 2011. Support vector machines in remote sensing: a review. *ISPRS Journal of Photogrammetry and Remote Sensing*, 66: 247–259. <https://doi.org/10.1016/j.isprsjprs.2010.11.001>.
- Nagendra H. 2001. Using remote sensing to assess biodiversity. *International Journal of Remote Sensing*, 22: 2377–2400. <https://doi.org/10.1080/01431160117096>.
- Orka H.O., Dalponte M., Gobakken T., Nasset E., Ene L.T. 2013. Characterizing forest species composition using multiple remote sensing data sources and inventory approaches. *Scandinavian Journal of Forest Research*, 28: 677–688. <https://doi.org/10.1080/02827581.2013.793386>.
- Stereńczak K., Mielcarek M., Modzelewska A., Kraszewski B., Fassnacht F.E., Hilszczański J., 2019. Intra-annual *Ips typographus* outbreak monitoring using multi-temporal GIS analysis based on hyperspectral and ALS data in the Białowieża Forests. *Forest Ecology and Management*, 442: 105–116. <https://doi.org/10.1016/j.foreco.2019.03.064>.
- Tagliabue G., Panigada C., Colombo R., Fava F., Cilia C., Baret F., Vreys K., Meuleman K., Rossini M. 2016. Forest species mapping using airborne hyperspectral APEX data. *Miscelanea Geographica*, 20: 28–33. <https://doi.org/10.1515/mgrsd-2016-0002>.
- Vapnik V.N. 1999. An overview of statistical learning theory. *IEEE Transactions on Neural Networks*. <https://doi.org/10.1109/72.788640>.
- Vauhkonen J., Orka H.O., Holmgren J., Dalponte M., Heinzel J., Koc, B. 2014. Forestry Applications of Airborne Laser Scanning, 27. <https://doi.org/10.1007/978-94-017-8663-8>.
- Wietecha M., Jełowicki Ł., Mitelsztedt K., Miścicki S., Stereńczak K. 2019. The capability of species-related forest stand characteristics determination with the use of hyperspectral data. *Remote Sensing of Environment*, 231. DOI: 10.1016/j.rse.2019.111232.
- Wietecha M., Modzelewska A., Stereńczak K. 2017. Wykorzystanie lotniczej teledetekcji hiperspektralnej w klasyfikacji gatunkowej lasów strefy umiarkowanej. *Sylwan*, 161(1): 3–17.
- Wolter P.T., Mladenoff D.J., Host G.E., Crow T.R. 1995. Improved forest classification in the northern Lake States using multi-temporal landsat imagery. *Photogrammetric Engineering & Remote Sensing*.

13. Comprehensive analysis of spruce dieback between 2015 and 2019 in the Białowieża Forest

Agnieszka Kamińska, Maciej Lisiewicz, Bartłomiej Kraszewski, Krzysztof Stereńczak

Forest Research Institute, Department of Geomatics, Sękocin Stary, 3 Braci Leśnej St., 05-090 Raszyn
{a.kaminska, m.lisiewicz, b.kraszewski, k.sterenczak}@ibles.waw.pl

Abstract

In recent years, temperate forests in Europe have been particularly vulnerable to the effects of extreme events such as prolonged droughts or strong winds, which have a direct impact on the weakening and consequent dieback of forest stands. In addition, hot summers with little rain and warm winters with little snow, contribute significantly to the development of insects and pathogens that affect tree health. As part of the project LIFE + ForBioSensing, multidirectional and comprehensive analyses of spruce dieback were carried out using various remote sensing techniques supported by reference field data. They confirmed that the existing outbreak, which started in 2012 and is still ongoing, seems to be the largest in the history of the Białowieża Forest. In the period from 2015 to 2019, this phenomenon developed intensively and reached its peak in 2016–2017. During the entire 4-year study period (2015–2019), 39% of all living spruce in the Białowieża Forest died in the upper layer of the stands (7% - 2015, 43% - 2019). The highest spruce mortality was recorded in the Białowieża Forest District, the lowest in the Białowieża National Park. The analyses carried out showed that the more open, older (over approx. 90 years old) spruce stands were the most susceptible to dieback in the initial phase of the outbreak. As a result of the thermal conditions in 2015, which were extremely favourable for the spread of the European spruce bark beetle, more spruce stands died in the forest in subsequent years. Areas with young trees less than 90 years old proved to be the most resistant to the pest. Topographical factors had only a minor influence on the spread of the Białowieża Forest outbreak.

Keywords: Białowieża Forest, outbreak dynamics, airborne laser scanning, spatial statistics

13.1. Introduction

In recent years, European temperate forests have been particularly vulnerable to the effects of extreme events such as prolonged droughts or strong winds, which have a direct impact on the weakening and subsequent dieback of forest stands (Senf et al. 2020, 2021). In addition, hot summers with little rain and warm winters with little snow contribute significantly to the development of insects and pathogens, which have a negative impact on tree health (Seidl et al. 2017). In commercial forests, foresters are partly able to intervene in the processes and limit the spread of a particular problem. The situation is different in forests with strict protection regulations, such as nature reserves or national parks. It is crucial to

understand the processes and factors affecting the dieback of individual tree species in order to limit this phenomenon in the context of forest conservation and management. Given the biodiversity and uniqueness of the Białowieża Forest (BF), it is extremely important to understand its current state and the dynamic processes taking place within it in order to better manage and protect forest stands.

The European spruce bark beetle (*Ips typographus* (L.)) is a permanent, integral component of spruce forest ecosystems. Under conditions of ecological equilibrium, this species acts as a driver of natural selection by eliminating individual weakened spruce from stands. For many years, mass occurrences of the bark beetle of enormous size and dynamics, which have the character of outbreaks, have been observed from time to time in some countries of Central and Northern Europe, including Poland. They cause enormous damage to ecosystems and also considerable economic losses. Therefore, comprehensive monitoring of forest health and identification of areas of widespread damage are essential (Dash et al. 2017; Sproull et al. 2017). For that reason, monitoring can be carried out using remote sensing techniques, which can support time-consuming field surveys (Latifi et al. 2014; Chakraborty et al. 2017; Meng et al. 2020). Knowledge of the spatial distribution of spruce stands affected by bark beetle infestations and tree mortality is essential for effective prevention or slowing down of these phenomena.

In the history of the Białowieża Forest, mass dieback of spruce stands due to bark beetle outbreak has occurred many times (Mokrzecki 1923; Grodzki 2016). There were several of them in the post-war period alone, and the dynamics of subsequent infestations has increased (Gutowski et al. 2003; Michalski et al. 2004; Stereńczak et al. 2020). Most of them were related to drought or wind damage, and the most recent outbreak, which started in 2012, seems to be the largest in the history of the Białowieża Forest (Grodzki 2016).

Within the Life+ ForBioSensing project, multidirectional studies were conducted on tree mortality in the Białowieża Forest, especially on the dieback of spruce stands due to bark beetle invasions. Among other things, the extent of the outbreak throughout the project, its temporal and spatial dynamics and the search for factors determining its development were studied. The analyses were carried out using a variety of remote sensing techniques supported by reference field data. Descriptions of some of the many methods and analyses used and the results have been published (Stereńczak et al. 2017; 2019; 2020; Kamińska et al. 2020, 2021). This chapter summarises the work done so far and presents the final picture of the impact of the bark beetle outbreak in BF stands in 2019.

13.2. Material and methods

13.2.1. Data characteristics

During the project, an extensive remote sensing dataset was acquired, which allowed for a comprehensive spatial characterisation of the study area. During the course of the project from 2015 to 2019, multispectral (satellite until 2016 and aerial from 2017), hyperspectral imaging data and airborne laser scanning data were acquired (Fig. 13.1). All data were used for the analysis of spruce dieback in the different years of the project. The description of the data, their quality control and the main processing steps can be found in earlier chapters (see Chapter 9).

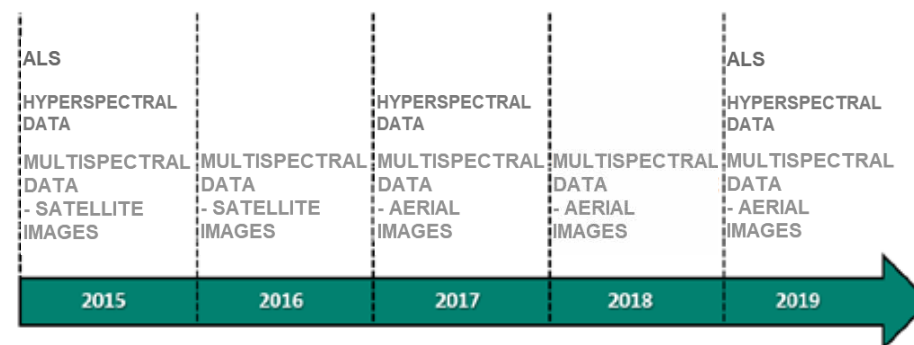

Figure 13.1. Remote sensing data used to analyse spruce dieback dynamics

13.2.2. Spatial autocorrelation

Spatial autocorrelation measures the degree to which the value of a variable for one spatial unit is related to the value of the same variable in another unit (location). Spatial autocorrelation was assessed using the global and local Moran's I statistics (Anselin 1995).

The global Moran's I coefficient is defined as follows:

$$I = \frac{1}{\sum_{i=1}^n \sum_{j=1}^n w_{ij}} \frac{\sum_{i=1}^n \sum_{j=1}^n w_{ij} (z_i - \bar{z})(z_j - \bar{z})}{\frac{1}{n} \sum_{i=1}^n (z_i - \bar{z})^2}$$

where:

n - number of observations,

z_i - value of variable for i -th location,

z_j - value of variable for j -th location,

- average value of the variable,

w_{ij} – weight between locations i and j based on contiguity, where the definition of neighbour was based on sharing of a common boundary (queen contiguity).

The global Moran's I coefficient indicates the existence of spatial autocorrelation - positive or negative. The value of the Moran's statistic ranges from about -1 to about 1. A value of 0 means no autocorrelation, negative values - negative autocorrelation, i.e. the presence of different values around each other. Positive values indicate positive autocorrelation, i.e. the presence of similar values next to each other. This means that we are dealing with spatial clusters.

The Local Indicators of Spatial Association (LISA) calculated for each location allows us to determine the similarity of the location to its neighbours and the statistical significance of this relationship. The values are calculated according to the following formula:

$$I_i = \frac{(z_i - \bar{z}) \sum_{j=1}^n w_{ij} (z_j - \bar{z})}{\sum_{i=1}^n (z_i - \bar{z})^2 / n}$$

By applying LISA, each spatial unit can be assigned to one of five classes (Zhang et al. 2008):

- Class 0 - unit with no significant local autocorrelation;
- Class 1 - unit with high value that has neighbours with a similar value („high-high”);
- Class 2 - unit with low value that has neighbours with a similar value („low-low”);
- Class 3 - unit with low value, which has neighbours with a high value („low-high”);
- Class 4 - unit with a high value that has neighbours with a low value („high-low”).

Using LISA, a typology of areas can be created according to spatial dependency. The global and local Moran's I significance level was tested based on a method called „conditional permutation” (Anselin 1995). A detailed description of the methodology used can be found in Stereńczak et al. (2020). Spatial analyses were performed using GeoDa software (version 1.12; Anselin et al. 2006). All maps were produced using ArcGIS software (ArcMap 10.5; ESRI, 2017).

13.3. Results and Discussion

13.3.1. Outbreak characteristics between 2015 and 2019

The results of the analysis of the remote sensing data for 2015–2019 showed that in the Białowieża Forest area in 2015 there were 283 166 dead spruce trees in the upper layer of the stand (i.e. an average of 4 dead trees per ha), which represented 7% of the total number of spruce trees (Tab. 13.1). Four years later, the total number of dead spruce trees was 1 854 195 (i.e. an average of 30 dead trees per ha), which represented 43% of the total number of spruce trees. During the analysed 4-year period of the outbreak (2015–2019), 39% of all living spruce in the upper layer of the stands in the Białowieża Forest died (on average 25 trees per ha) (Tab. 13.1).

The bark beetle infestation proceeded with different dynamics in the individual fragments of the BF (Fig. 13.2–13.3). The highest proportion of dead spruce was recorded in 2015 and 2019 in the Białowieża F.D., with 11% and 51%, respectively. In contrast, the lowest proportion was recorded in the Hajnówka F.D. in 2015 (4%) and in the Białowieża National Park (BNP) in 2019 (27%). Although the number of dead spruce trees in 2015 was by far the highest in the Białowieża F.D. (111 042), in 2019 there were the most such trees in the Browsk (587 555) and Hajnówka (586 639) Forest Districts. However, this was not directly reflected in the highest dynamics of spruce mortality between 2015 and 2019 in the above forest districts, which was highest in the Białowieża F.D. (45%) and lowest in the Białowieża National Park (20%) (Tab. 13.1).

Table 13.1. Results of dead spruce detection in the top forest layer in the years 2015–2019

Area type	2015		2019		2015 - 2019	
	number	percentage [%]	number	percentage [%]	number	percentage [%]
<i>Białowieża F. D.</i>	111042	10.86	525708	51.40	414666	45.48
<i>Browsk F.D.</i>	67815	5.43	587555	47.05	519740	44.01
<i>Hajnówka F. D.</i>	54781	3.74	586639	40.01	531858	37.68
<i>Białowieża N.P.</i>	49528	8.76	154293	27.29	104765	20.31
<i>Total</i>	283166	6.58	1854195	43.09	1571029	39.08

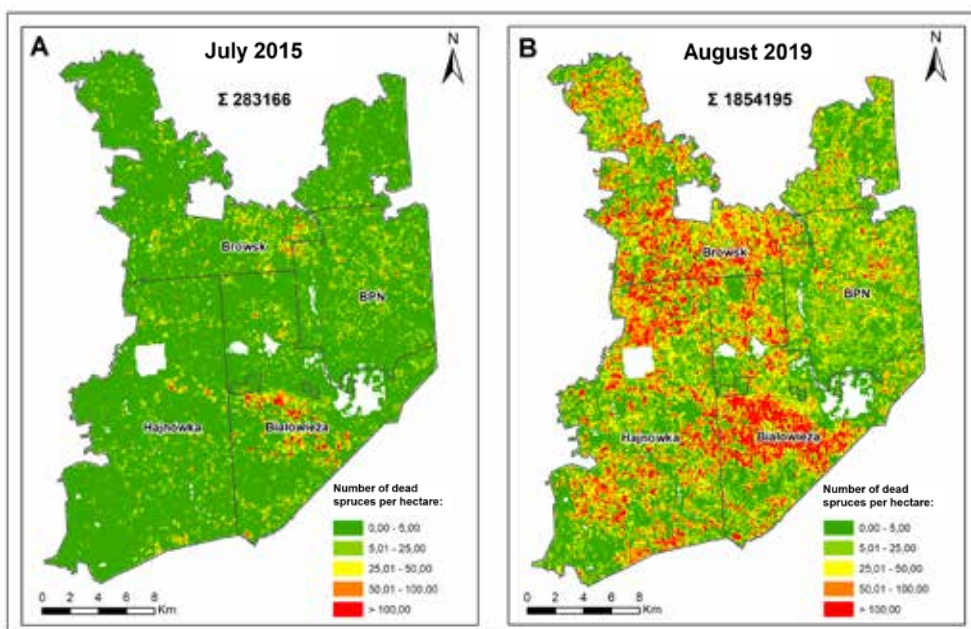

Figure 13.2. Number of dead spruce trees per hectare in 2015 (A) and 2019 (B)

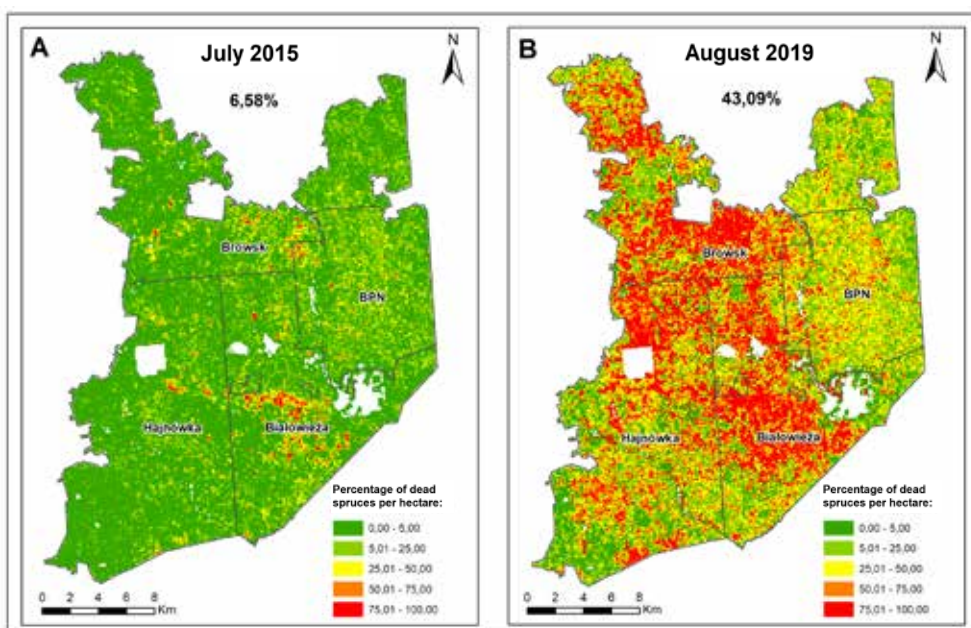

Figure 13.3. Percentage of dead spruce trees per hectare in 2015(A) and 2019 (B). [source: Kamińska A., Lisiewicz M., Kraszewski B., Stereńczak K. 2021. Mass outbreaks and factors related to the spatial dynamics of spruce bark beetle (*Ips typographus*) dieback considering diverse management regimes in the Białowieża forest, Forest Ecology and Management, Volume 498, 119530, <https://doi.org/10.1016/j.foreco.2021.119530>]

13.3.2. The spatial dynamics of the outbreak between 2015 and 2019

After dividing the area of the Białowieża Forest into 1-ha cells, we analysed the spatial dynamics of spruce dieback during the project period (Fig. 13.4). The spatial variation of the outbreak level in 2015 is low. In most areas, no negative effects of bark beetle activity were observed, which was largely determined by the area share of spruce in the BF stands (about 22% in the upper and dominant tree layer in 2015 (see Chapter 12). However, the concentration of the outbreak is evident in the Białowieża F.D., which forms the so-called „Białowieża cluster”, which can be considered the largest centre of pest invasion in the initial phase. It should be noted that among the tree species forming the BF, the area share of spruce (as the dominant tree species) is the highest in this forest district; the VI class and the older age classes also have the highest share of spruce stands (Grodzki 2016).

In 2019, a significant intensification of the dieback of spruce stands can already be observed throughout the study area. This is confirmed by high values of the Moran index ($I=0.57$ (for percentages), $I=0.54$ (for numbers), indicating a clear tendency towards spatial polarisation. However, the spatial dynamics of spruce mortality in the Białowieża Forest in the Browski, Białowieża and Hajnowka Forest Districts is significantly different from that in the Białowieża National Park (Figs. 13.2–13.5). In 2019, the „Białowieża cluster” is visible because outbreaks seem to remain concentrated in this area. However, we observe a significant expansion of the cluster. In addition, the territorial spread of areas with bark beetle-infested spruces in other forest areas is clearly visible - many newly emerged outbreaks of different sizes were recorded. Near these clusters, there are “low-high” outliers where the dynamics of tree mortality are significantly lower than in neighbouring areas. Among them, stands were observed that were infested by bark beetles in the initial phase of the outbreak, and in these areas the process was saturated in the analysed period. However, some of the „low-high” areas were not infested in 2015, which could indicate a development of the bark beetle infestation in the future.

There are a number of areas in the Białowieża National Park that are resistant to bark beetle infestation. No significant outbreak centre was recorded there. However, it is interesting that quite numerous „high-low” outliers were observed, indicating the dieback of individual spruces. The Białowieża National Park is characterised by high species variability and a „mosaic” of habitats. There are only a few areas covered by spruce monocultures. Mostly, spruce trees are part of multi-generation and multi-species stands. In 1994–1996 and 2000–2004 (Michalski et al. 2004), there were also beetle-induced outbreaks in the BNP that decimated the spruce population in this area (Miścicki 2012). As a result, the lower spruce mortality in the BNP compared to other forest areas is most likely due to the lower availability of trees and the pressure of parasitoids and predators on the bark beetle population.

Annual monitoring of tree mortality in the Białowieża Forest conducted as part of the project showed that this phenomenon peaked in 2016–2017, first in the area of the Białowieża F.D., and somewhat later in the other forest districts. In the area of the National Park, where the lowest dynamics of spruce mortality was observed, it was relatively uniform. This is largely due to the hot and dry growing season and the long and warm autumn of 2015, when thermal conditions were exceptionally favourable for bark beetle reproduction, leading to an acceleration of the development of the preimaginal stages and an increase in the number of new generations (Grodzki 2016).

It should be noted that the development of bark beetle infestation was already very dynamic during one growing season. Monitoring of this phenomenon in 2015 showed the occurrence of new outbreaks not only in the immediate vicinity of previously dead trees, but also in areas more than 100 m away from previously infested specimens (Stereńczak et al. 2019).

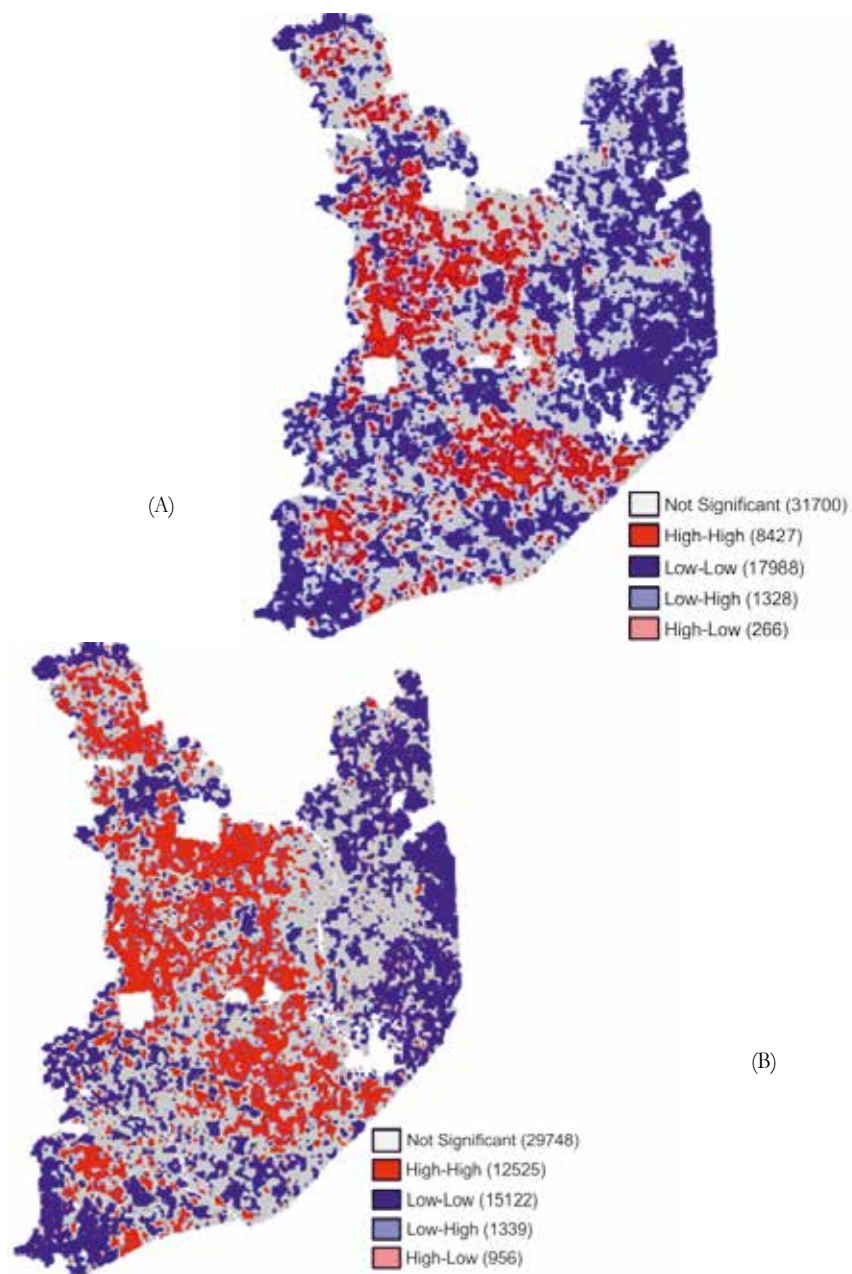

Figure 13.4. Area types by spatial relationship of spruce dieback dynamics between 2015 and 2019: numerically (A), percentage (B)

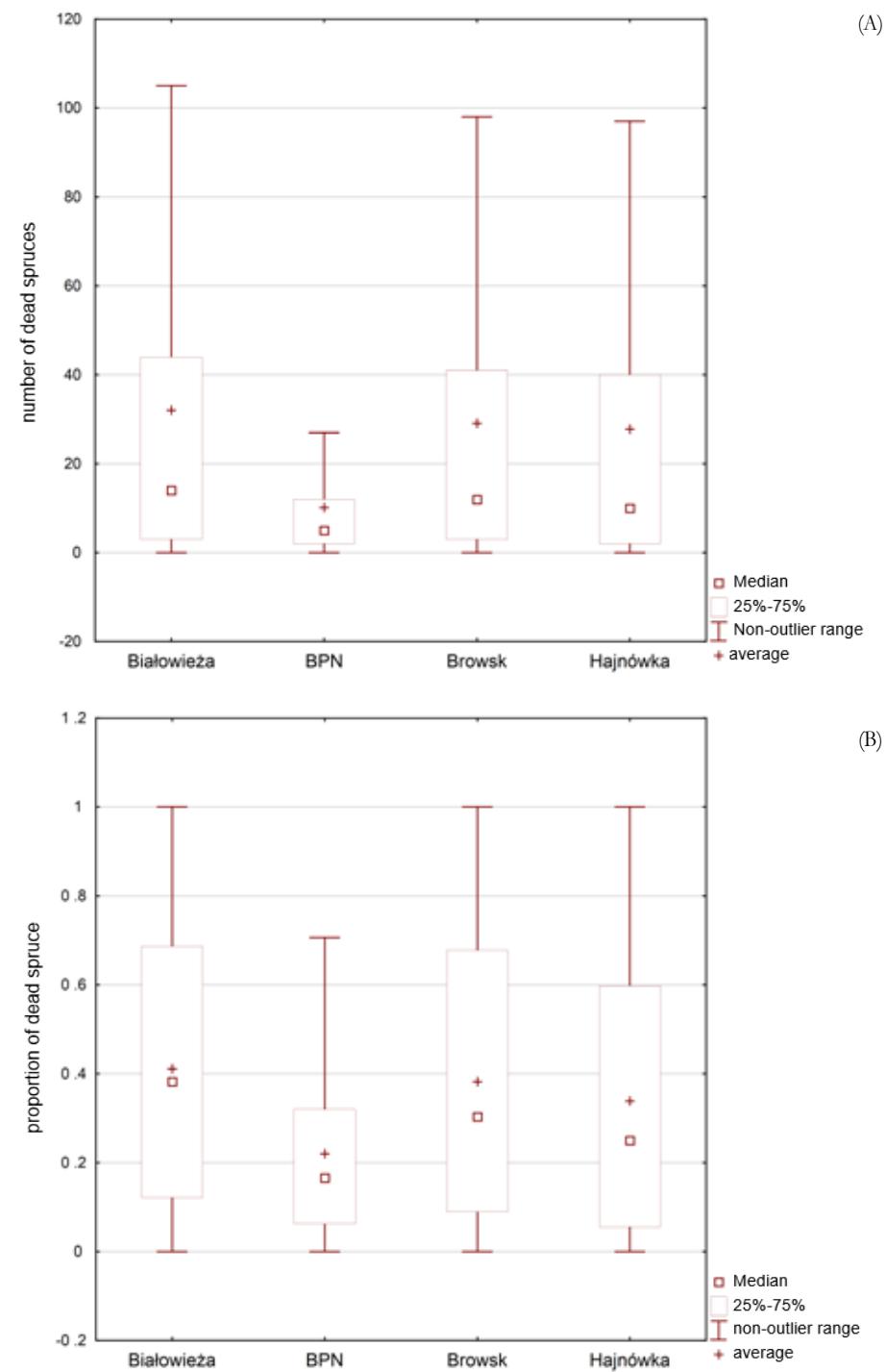

Figure 13.5. Dynamics of spruce dieback by forest district between 2015 and 2019: numerically (A), percentage (B)

13.3.3. Outbreak Determinants

Within the project, multidirectional studies on the influence of selected habitat, stand and topographic factors on spruce mortality were conducted (Kamińska et al. 2020; 2021; Stereńczak et al. 2020). The analyses on the occurrence of dead spruce in 2015 made it possible to consider crown closure and stand age as the most important predictors of the initial phase of spruce mortality in BF. More open, older spruce stands were most susceptible to dieback during this period (Stereńczak et al. 2020).

Most of the stands attacked by the bark beetle were over 90 years old. Previous studies suggest that trees older than 60 (Netherer and Schopf 2010) or 100 years are more susceptible to such attacks (Becker and Schröter 2000; Netherer and Nopp-Mayr 2005; Grodzki 2014). This is related to the fact that the bark beetle prefers thicker trees in which the larvae can fully develop their galleries (Lausch et al. 2011). In addition, stand age was an important stimulator of bark beetle infestation in all its phases in the Tatra Mountains (Mezei et al. 2014). Another factor influencing spruce mortality was crown closure. It was found that relatively open stands (50-70% crown closure) were more prone to dieback. This could be related to the microclimate, i.e. more light can penetrate through open stands, leading to higher temperatures in the stand and around the tree trunks. Higher temperatures have a positive effect on the reproduction, oviposition and growth, which directly affects the number of generations per year (Wermelinger 2004). It was also observed that even individual spruces in mixed forests were infested with bark beetles, indicating the strong infestation pressure in these forest stands. This is further evidence that areas with a high proportion of mixed tree species do not form barriers to the spread of bark beetles, at least not at the outbreak stage studied.

Studies by Kamińska et al. (2020; 2021) analysed the dynamics of spruce dieback and factors determining the dynamics of spruce bark beetle dieback in the Białowieża Forest. In both studies, stand height and the proportion of spruce were found to be stimulating factors for bark beetle infestation. The proportion of the area covered by tree crowns, excluding spruce, in turn destimulated the timing of spruce mortality. This means that the most intense outbreak occurred in old stands dominated by spruce. At BF, no natural barriers were found to prevent mortality from spreading in any direction. The observed significant increase in tree mortality dynamics in BF, especially at spruce heights above about 15-20 m, is consistent with previous studies (Eriksson et al. 2005; Akkuzu et al. 2009; Schroeder 2010; Mezei et al. 2014). Netherer and Nopp-Mayr (2005) and Overbeck and Schmidt (2012) showed a positive correlation between the risk of tree mortality and the proportion of spruce. On the other hand, the hypothesis that the presence of trees other than spruce in spruce stands reduces the risk of beetle invasion was also demonstrated by Zhang et al. (1999) and Zhang and Schlyter (2004).

It is worth noting that topographic factors had a marginal effect on mortality dynamics in the BF. None of the variables studied (aspect, slope, topographic position index (TPI), elevation, SAGA Wetness Index) showed a significant influence on the dynamics of the phenomenon studied. This result was not surprising, as the BF does not have large differences in altitude, so that a clear influence of the terrain on the mortality dynamics was hardly to be expected. In practice, however, one could get the impression that the local hills determined a higher intensity of spruce mortality than the local depressions of the area. Perhaps the nature of these processes is very localised, so that the field observations could not be confirmed by large-scale analyses.

13.4. Conclusion

The multidirectional and comprehensive analyses of spruce mortality conducted as part of the LIFE+ ForBioSensing project have confirmed that the current bark beetle outbreak, which began in 2012 and is still ongoing, appears to be the largest in the history of the Białowieża Forest. In the period from 2015 to 2019, this phenomenon developed intensively and reached its peak in 2016-2017. During the entire 4-year period of the outbreak (2015–2019), 39% of all living spruce died in the upper layer of stands in the Białowieża Forest in 2015 (7% - 2015, 43% - 2019).

The highest bark beetle outbreak dynamics were recorded in the Białowieża F.D. During the studied period, 45% of all living spruce trees in this forest district died. The highest percentage of dead trees of this species was recorded in this area both at the beginning and at the end of the studied period (11% - 2015, 51% - 2019). This was the result of the largest spruce mortality dynamics observed in the Białowieża Forest in 2015 (the so-called „Białowieża cluster”).

In the BNP, the lowest dynamics of spruce mortality were observed compared to other forest districts. Between 2015 and 2019, 20% of the living spruce trees died in BNP, while in other forest districts more than 35% of the trees of this species died (9% - 2015, 27% - 2019). No significant bark beetle outbreak was recorded there.

The analyses conducted showed that the more open, older (above approximately 90 years old) spruce stands were most susceptible to dieback in the initial phase of the outbreak. As a result of the thermal conditions in 2015, which were extremely favourable for the spread of the European bark beetle, more spruce stands in the forest died back in subsequent years. Areas with young trees less than 90 years old proved to be the most resistant to the pest. Topographic factors had little influence on the spatial spread of the outbreak.

The presented results indicate the possibility of further development of bark beetle-induced mortality in the Polish part of the Białowieża Forest. The proportion of spruce in BF stands has been significantly reduced, but spruce still forms monocultures in some places. These places should be included in the monitoring of their condition in the coming years.

References

- Akkuzu E., Sariyildiz T., Kucuk M., Duman A. 2009. *Ips typographus* (L.) and *Thanasimus formicarius* (L.) populations influenced by aspect and slope position in Artvin-Hatila valley national park, Turkey. *African Journal of Biotechnology*, 8(5): 877–882.
- Anselin L. 1995. Local indicators of spatial association-LISA. *Geographical Analysis*, 27: 93–115.
- Anselin L., Syabri I., Kho. Y. 2006. GeoDa: An Introduction to Spatial Data Analysis. *Geogr. Geographical Analysis*, 38: 5–22.
- Becker T., Schröter H. 2000. Ausbreitung von rindenbrütenden Borkenkäfern nach Sturm-schäden. *Allgemeine Forstzeitung*, 55: 280–282.
- Chakraborty A., Ghosh A., Sachdeva K., Joshi P.K. 2017. Characterizing fragmentation trends of the Himalayan forests in the Kumaon region of Uttarakhand, India. *Ecological Informatics*, 38: 9–109.
- Dash J.P., Watt M.S., Pearse G.D., Heaphy M., Dungey H.S. 2017. Assessing very high resolution UAV imagery for monitoring forest health during a simulated disease outbreak. *ISPRS J. Photogramm. Remote Sens.* 131: 1–14.
- Eriksson M., Pouttu, A., Roininen H. 2005. The influence of windthrow area and timber characteristics on colonization of wind-felled spruces by *Ips typographus* (L.). *Forest Ecology and Management*, 216: 105–116.
- ESRI 2017. ArcGIS Desktop: Release 10.5, Environmental Systems Research Institute, Redlands, CA, USA.
- Grodzki W., Starzyk J.R., Kosibowicz M., 2014. Impact of selected stand characteristics on the occurrence of the bark beetle *Ips typographus* (L.) in the Beskid Żywiecki Mountains. *Forest Research Papers*, 75: 159–169. DOI: 10.2478/frp-2014-0015.
- Grodzki W. 2016. Mass outbreaks of the spruce bark beetle *Ips typographus* in the context of the controversies around the Białowieża Primeval Forest. *Forest Research Papers*, 77: 324–331. DOI: 10.1515/frp-2016-0033.
- Gutowski J.M., Grodzki W., Paluch R., Keczyński A., 2003. Określenie wpływu kornika drukarza na drzewostany z udziałem świerka w obszarze ochrony ścisłej Białowieskiego Parku Narodowego w kontekście przebiegu tych samych zjawisk w lasach gospodarczych i rezerwatach przyrody Puszczy Białowieskiej. Ekspertyza 26-U-11 wykonana na zlecenie Wojewódzkiego Konserwatora Przyrody w Białymstoku. Instytut Badawczy Leśnictwa, Warszawa.
- Kamińska A., Lisiewicz M., Stereńczak K., Kraszewski B. 2020. Habitat and stand factors related to spatial dynamics of Norway spruce dieback driven by *Ips typographus* (L.) in the Białowieża Forest District. *Forest Ecology and Management*, 476. DOI: 10.1016/j.foreco.2020.118432.
- Kamińska A., Lisiewicz M., Kraszewski B., Stereńczak K. 2021. Mass outbreaks and factors related to the spatial dynamics of spruce bark beetle (*Ips typographus*) dieback considering diverse management regimes in the Białowieża forest, *Forest Ecology and Management*, 498, 119530, DOI: 10.1016/j.foreco.2021.119530.
- Latifi H., Schumann B., Kautz M., Dech S. 2014. Spatial characterization of bark beetle infestations by a multirate synergy of SPOT and Landsat imagery. *Environmental Monitoring and Assessment*, 186: 441–456.
- Lausch A., Fahse L., Heurich M. 2011. Factors affecting the spatio-temporal dispersion of *Ips typographus* (L.) in Bavarian Forest National Park: A long-term quantitative landscape-level analysis. *Forest Ecology and Management* 261, 233–245. DOI: 10.1016/j.foreco.2010.10.012.
- Meng Y., Liu X., Ding C., Xu B., Zhou G., Zhu L. 2020. Analysis of ecological resilience to evaluate the inherent maintenance capacity of a forest ecosystem using a dense Landsat time series. *Ecological Informatics*, 57, 101064.
- Mezei P., Grodzki W., Blaženec M., Škvarenina J., Brandýsová V., Jakuš R. 2014. Host and site factors affecting tree mortality caused by the spruce bark beetle (*Ips typographus*) in mountainous conditions. *Forest Ecology and Management*, 331: 196–207. DOI: 10.1016/j.foreco.2014.07.031
- Michalski J., Starzyk J.R., Kolk A., Grodzki W. 2004. Zagrożenie świerka przez kornika drukarza – *Ips typographus* (L.) w drzewostanach Leśnego Kompleksu Promocyjnego „Puszcza Białowieska” w latach 2000–2002. *Leśne Prace Badawcze*, 3: 5–30.
- Miścicki S. 2012. Structure and dynamics of temperate lowland natural forest in the Białowieża National Park, Poland. *Forestry: An International Journal of Forest Research*, 85(4): 473–483. DOI: 10.1093/forestry/cps044.
- Mokrzejcki Z. 1923. Sprawozdanie z walki z kornikiem w Puszczy Białowieskiej w 1922. *Las Polski*, 4: 297–307.
- Netherer S., Nopp-Mayr U. 2005. Predisposition assessment systems (PAS) as supportive tools in forest management—rating of site and stand-related hazards of bark beetle infestation in the High Tatra Mountains as an example for system application and verification. *Forest Ecology and Management, Decision Support in Multi Purpose Forestry*, 207: 99–107. DOI: 10.1016/j.foreco.2004.10.020.
- Netherer S., Schopf A. 2010. Potential effects of climate change on insect herbivores in European forests—general aspects and the pine processionary moth as specific example. *Forest Ecology and Management*, 259: 831–838.
- Overbeck M., Schmidt M. 2012. Modelling infestation risk of Norway spruce by *Ips typographus* (L.) in the Lower Saxon Harz Mountains (Germany). *Forest Ecology and Management*, 266: 115–125. DOI: 10.1016/j.foreco.2011.11.011.
- Seidl R., Thom D., Kautz M., et al. 2017. Forest disturbances under climate change. *Nature Climate Change*, 7: 395–402. DOI: 10.1038/nclimate3303.

- Senf C., Buras A., Zang C.S. Rammig A. Seidl R. 2020. Excess forest mortality is consistently linked to drought across Europe. *Nature Communications*, 11, 6200. DOI: 10.1038/s41467-020-19924-1.
- Senf C., Seidl R. Mapping the forest disturbance regimes of Europe. *Nature Sustainability*, 4: 63–70 (2021). DOI: 10.1038/s41893-020-00609-y.
- Schroeder L.M. 2010. Colonization of storm gaps by the spruce bark beetle: influence of gap and landscape characteristics. *Agricultural and Forest Entomology*, 12: 29–39.
- Sproull G.J., Bukowski M., Mcnutt N., Zwijacz-Kozica T., Szwagrzyk J., 2017. Landscape-Level spruce mortality patterns and topographic forecasters of bark beetle outbreaks in managed and unmanaged forests of the Tatra Mountains. *Polish Journal of Ecology*, 65: 24–37.
- Stereńczak K., Kraszewski B., Mielcarek M., Piasecka Ż. 2017. Inventory of standing dead trees in the surroundings of communication routes – remote sensing contribution to the potential risk assessment. *Forest Ecology and Management*, 402: 76–91. DOI: 10.1016/j.foreco.2017.07.018
- Stereńczak K., Mielcarek M., Modzelewska A., Kraszewski B., Fassnacht F.E., Hilszczański J. 2019. Intra-annual *Ips typographus* outbreak monitoring using a multi-temporal GIS analysis based on hyperspectral and ALS data in the Białowieża Forests. *Forest Ecology and Management*, 442: 105–116. DOI: 10.1016/j.foreco.2019.03.064.
- Stereńczak K., Mielcarek M., Kamińska K., Kraszewski B., Piasecka Ż., Miścicki M., Heinrich M. 2020. Influence of selected habitat and stand factors on bark beetle *Ips typographus* (L.) outbreak in the Białowieża Forest. *Forest Ecology and Management*, 459 (117826): 1–11. DOI: 10.1016/j.foreco.2019.117826.
- Wermelinger B. 2004. Ecology and management of the spruce bark beetle *Ips typographus*—a review of recent research. *Forest Ecology and Management*, 202: 67–82.
- Zhang, C., Luo, L., Xu, W., Ledwith, V., 2008. Use of local Moran's I and GIS to identify pollution hotspots of Pb in urban soils of Galway, Ireland. *Science of The Total Environment*, 398: 212–221. DOI: 10.1016/j.scitotenv.2008.03.011.
- Zhang Q.H., Birgersson G., Zhu J.W., Löfstedt C., Löfqvist J., Schlyter F. 1999. Leaf volatiles from non-host deciduous trees: variation by tree species, season and temperature, and electrophysiological activity in *Ips typographus*. *Journal of Chemical Ecology*, 25: 1923–1943. DOI: 10.1023/A:1020994119019.
- Zhang Q.H., Schlyter F. 2004. Olfactory recognition and behavioural avoidance of angiosperm non-host volatiles by conifer-inhabiting bark beetles. *Agricultural and Forest Entomology*, 6: 1–20. DOI: 10.1111/j.1461-9555.2004.00202.x.

14. Modelling the light conditions in the forest stands of Białowieża Forest

**Żaneta Piasecka, Małgorzata Białczak, Agnieszka Kamińska,
Krzysztof Stereńczak**

Forestry Research Institute, Department of Geomatics, Sękocin Stary, 3 Braci Leśnej St.,
05-090 Raszyn
{ z.piasecka, m.bialczak, a.kaminska, k.sterenczak }@ibles.waw.pl

Abstract

One of the factors critical to the growth and functioning of vegetation in the forest is access to sunlight. Determining the amount of light reaching the forest floor allows us to understand its impact on changes in the stand, such as the formation of a new forest generation, called regeneration. Obtaining information on the amount of solar radiation penetrating beneath the canopy of a stand for a large forest complex is possible through remote sensing.

The aim of this study was to use airborne laser scanning (ALS) technology and hemispheric imaging to model the amount of solar radiation reaching the forest floor. The study area covered the Polish part of Białowieża Forest. The reference data for the construction of solar radiation models were solar radiation values obtained from hemispheric images taken for 96 field plots. The modelling process used variables (characteristics) extracted from a point cloud (LPI, Rhmean, RH_{DBH} median, R1%). Surveys were carried out for two dates: 2015 and 2019. The construction of the models consisted of 3 stages: calculation of the values of the independent variables, construction of models of direct, diffuse and global solar radiation, and assessment of the accuracy of the models.

For the models built for 2015 and 2019, high fitting accuracies of R² coefficient in the range of 0.842 - 0.898 were obtained. The result of the implementation of the models were maps of solar radiation under the tree canopy for the entire study area for two dates. The study confirms that there is a strong relationship between the point cloud characteristics of airborne laser scanning and the amount of sunlight reaching the forest floor.

Keywords: solar radiation, modelling, hemispheric images, remote sensing

14.1. Introduction

The availability of sunlight in the forest is particularly important for the functioning of undergrowth species. In forests, solar radiation significantly affects biological and physical processes such as plant growth, the carbon cycle and photosynthesis (Schleppi and Paquette 2017). The amount of solar radiation depends mainly on the stand structure. The

radiation beneath the canopy is mainly the photosynthetically active radiation (PAR) in the electromagnetic wavelength range, roughly between 400 and 700 nm (Comeau 2000). This sub-canopy radiation is defined as that which is used by plants for photosynthesis. There is a distinction between direct radiation, diffuse radiation, and global radiation which is the sum of the previous two. Direct radiation is that which is emitted directly by the solar disk. Reaching the atmosphere, it is absorbed, reflected and diffused. Scattered radiation consists mainly of the energy of direct radiation dispersed by the atmosphere. The variability of energy from scattered radiation depends mainly on the cloud cover and of the sun's angle above the horizon. The more cloud cover, the higher the diffuse radiation can be.

A stand's exposure to the sun can be measured directly (e.g., actinometer, laiometr) and indirectly (e.g., using hemispheric photos) (Schleppi and Paquette 2017). Direct methods employ sensors to quantitatively measure radiation, e.g.: total solar radiation or photosynthetically active radiation. Sensors are placed under different types of vegetation at multiple locations to quantify spatial and temporal variability over a certain time (Bode et al. 2014). Because of the difficulties with direct measurement of exposure to the sun in the forest, such as time, cost, and areas being extensive or difficult to access, indirect measurement methods are preferred (Jennings et al. 1999). Currently, hemispheric imaging is one of the basic and most commonly used methods to survey the forest structure and the amount of radiation reaching the forest floor. Imagery is taken with a camera with a "fish-eye" lens, capturing 180° images. The result is a circular image, which is a projection of the hemisphere onto a flat surface (Rich 1990). Hemispheric photographs were first used in the 1920s for meteorological observations of clouds, and 35 years later they were first used in surveys of forest environments (Evans and Coombe 1959). An upward-pointing camera with a fish-eye lens records the geometry of tree crowns (Chianucci and Cutini 2012), which makes it directly possible to calculate e.g. the translucence of the canopy (Welles and Cohen 1996; Frazer et al. 2001; Jonckheere et al. 2005), the amount of radiation reaching the floor of the forest (Anderson 1964; Becker et al. 1989; Rich et al. 1993; Hardy et al. 2004), and the leaf area index (LAI; Bonhomme et al. 1974; Soudani et al. 2002; Leblanc et al. 2005; Macfarlane et al. 2007).

Airborne laser scanning (ALS) data are widely used in forestry (Mallet and Bretar 2009). The details of the data allow the extraction of individual tree crowns as segments (Reitberger et al. 2011) and obtaining tree height information (Mielcarek et al. 2020). In the general aspect, we obtain information about the structure of the entire stand. The capability of laser pulses to penetrate particular storeys of vegetation results in obtaining full information on the stand from the ground layer to the top of the tallest tree.

There was an increased interest in measuring sunlight in the forest using remote sensing data around 2010, and since then Lidar data has been used more than once to model sunlight under the canopy (Olpenda et al. 2018).

Among the concepts mentioned in the literature, two most commonly used groups of methods can be distinguished. One of them are methods based on the reconstruction of a stand

by building a three-dimensional model using, among others, voxels (a voxel - the smallest element in a three-dimensional space). Based on the information obtained about the stand structure, the light penetration in the stand is simulated according to Beer's law. However, it has been noted that the above method is impractical in a natural environment with high species diversity (Bode et al. 2014). Increasingly, methods using (statistical) metrics based on reflection return from a LiDAR point cloud are being used to estimate sunlight under the tree canopy. Metrics (features) can range from simple statistics to more complex ones that can be tailored to specific user applications. Statistics used in forestry are calculated based mainly on information about the height and intensity of points representing a stand. The most commonly used ALS metric for studies related to light penetration is the Laser Penetration Index (LPI) (Hopkinson and Chasmer, 2007).

Many papers using ALS technology stand out in the literature. The possibilities of using ALS to estimate sunlight in a forest are detailed in the review paper by Olpenda et al. 2018.

The Life+ ForBioSensing project built solar radiation models estimating the amount of direct, diffuse and total (global) radiation based on two sets of airborne laser scanning data acquired in 2015 and 2019, and using previous observations from the area (Olpenda et al. 2019), in addition to solar radiation maps of Białowieża Forest for both dates. The hemispheric images, which were acquired in the project mainly to analyse the magnitude of solar radiation under the canopy of the stand and stand canopy cover, were used to calculate solar radiation values as a reference for building models. The solar radiation models built, initiated in a PhD thesis (Olpenda 2018), were used to estimate the amount of solar radiation reaching beneath the canopy of forest stands. To our knowledge, this type of research has not been conducted before in such a vast and species-diverse area as Białowieża Forest.

14.2. Materials and Methods

14.2.1. Data

Aerial laser scanning data collected during the 2015 and 2019 growing seasons were used to build solar radiation models. The description of the data and the conditions for their acquisition and processing are described above (see Chapter 9). The starting point for the construction of solar radiation models were the results of previous analyses of the characteristics of airborne laser scanning data (Olpenda 2018; Olpenda et al. 2019) Four variables (characteristics) generated from the point cloud acting as independent variables were used to build the models: LPI - laser penetration index (canopy openness), R1% - percentage of first laser reflections, RHmean - average reflection height of laser pulses and RH_{DBH}median - median reflection height of laser pulses (Olpenda 2018).

Hemispheric images for the Białowieża Forest area were acquired in the years: 2015, 2017 and 2019, during the growing season, in July and August. Out of almost 700 circular

monitoring plots located in the area of the Forest, 100 plots located in the Browsk, Hajnówka and Białowieża Forest Districts were selected. More than a half of the selected plots (68) were located in forest habitats (fresh deciduous forest - 34 plots, fresh mixed deciduous forest - 20 plots, humid deciduous forest - 12 plots, humid mixed deciduous forest - 2 plots), 23 plots included boreal habitats (fresh mixed coniferous forest - 18 plots, fresh coniferous forest - 5 plots) and the remaining (9) in alder habitats (ash-alder swamp forest - 5 plots, alder bog forest - 4 plots). The distribution of the selected plots reflects the overall distribution of all 685 monitoring plots located within the Forest boundaries, where about 60% are forest habitats, more than 21% are boreal habitats, 15% are alder habitats and the remaining 4% are non-forest habitats.

For each of the 100 monitoring plots, 15 photographs were scheduled to be taken. 3 images, with different exposures (EV: 0, EV: +1, EV: -1), were taken at the centre point of the plot, then 3 images each at a distance of 5 m from the centre in the east, west, north and south directions. However, during the course of the fieldwork, fewer photographs were taken for some plots. The most common reason for not taking additional images was dense undergrowth or the fact that the plot was in a gap. It was then impossible or pointless to take images. In subsequent measurement years, hemispheric images were taken with a Canon EOS 5D Mark III camera (EF 24-105, f/4L IS USM KIT) equipped with a Sigma 8 mm F3.5 EX DG fisheye lens. The camera was positioned so that its lens was at a height of 1.30 m and oriented in a north-south direction so that magnetic north was at the top of the image. In addition, a precise GPS location was taken for each measuring point.

As 4 field plots had fewer than 10 trees over 1.30 m in height, they were excluded from the reference data set. Plot characteristics were analysed in detail in the study by Olpenda (2018). Finally, 96 plots were selected as reference plots for solar radiation modelling.

14.2.2. Processing of hemispheric images to obtain solar radiation reference values

14.2.2.1. Image selection

The initial and most important stage in the process of analysing hemispheric images is their classification, i.e. assigning each pixel of the image to one of two classes - vegetation or sky. The classification can be automatic or manual, and the result is significantly influenced by the lighting conditions under which the images were taken. Due to the different atmospheric and lighting conditions prevailing at the time of the fieldwork, the most high-contrast images were initially selected for each plot, where the leaves and branches were the darkest and the sky the brightest. Depending on the area, between 1 and 5 images were selected for which analyses were performed using WinSCANOPY software version 2014a.

14.2.2.2. Image classification

Automatic classification was initially carried out for the selected hemispheric images. Each colour image was converted to a 16 bit grayscale image (65,536 (2^{16}) shades of grey), where a pixel with a value of 0 was black and 65,536 was white. A histogram of values was then created for the image and a class membership threshold was automatically selected. Pixels with values lower than the indicated threshold were assigned to the „vegetation” class and those with higher values to the „sky” class. From this, a binary image was generated, assigning each pixel to one of the classes. The classification results were subjected to visual interpretation. Due to the heterogeneous lighting conditions, automatic classification did not always give satisfactory results. For images with non-uniform cloud cover, it was necessary to select the classification threshold manually by trial and error. In some cases, bright elements of tree bark, reflecting solar radiation, or very dark cloud fragments, required manual correction of the results. In addition, for images where the contrast between vegetation and sky was not great, a different classification method was used - based on colour. This consisted of manually indicating a maximum of 12 areas representing the class „vegetation” and 12 areas representing the class „sky”. According to the indicated areas, based on hue, saturation and colour intensity, class signatures were created, on the basis of which the classification of the images was made. Only when all images had been checked and correctly classified was the subsequent stage of analysis initiated.

14.2.2.3. Calculation of the radiation reaching the forest floor

The assumption underlying analyses of the amount of radiation reaching the forest floor from hemispheric images is that it penetrates openings in the stand (Rich 1989). The openings allow the free flow of total radiation, which consists of diffuse and direct radiation. Direct radiation is referred to when the sun is in line with a given opening in the stand, while diffuse radiation is indirect radiation, scattered by the atmosphere. For the analysis of hemispheric images, radiation transmitted through or scattered by the leaves is omitted. The analysis of solar radiation therefore implies the summation of the direct and diffuse radiation that can be expected at a given measurement location.

The direct radiation for a particular location depends primarily on the relative position of the sun, which changes throughout the day and year (Rich 1989). To be able to determine these for each hemispheric image, the date and time the image was taken, the geographical coordinates and altitude of where the image was taken, and the orientation of the image must be provided. This information is automatically extracted from the metadata of the images taken in the field. In addition, it is necessary to specify the time zone in which the images were taken, the magnetic declination which varies for a given measurement year and the length of the growing season. Based on the data entered, the apparent movement of the sun during the indicated time interval is plotted on the image. Then, for pixels classified as sky and coinciding directly with lines of apparent solar movement, the radiation to the forest floor is assumed to arrive unchanged and equal to the radiation reaching the upper boundary of the forest stand. Meanwhile, for pixels classified as vegetation, the radiation is

completely blocked and does not reach the forest floor. On this basis, the daily amount of direct radiation reaching the forest floor is calculated.

Diffuse radiation is initially measured for the upper stand boundary using atmospheric radiation scattering models for clear skies (Rich et al. 1999). A grid of 18 concentric rings divided into 8 equal sections is then superimposed on the image. For each grid fragment, the diffuse radiation reaching the upper stand boundary is superimposed, and then the diffuse radiation reaching the forest floor is calculated using variables such as the ratio of pixels classified as sky for a given ring fragment, the area of the analysed ring fragment relative to the total field of view of the lens, and the elevation angle and zenith angle for the centre of the concentric rings (WinSCANOPY 2014).

14.2.3. Construction of solar radiation models

The project built 3 insolation models: a total radiation model and direct and diffuse radiation models. Solar radiation prediction models were built, based on 4 independent variables, using the multiple regression method which is proposed by Olpenda (2018). The direct and total radiation models were built based on 3 independent variables: LPI, RHmean and RH_{DBH} median, while the variable R1 was added to the diffuse radiation model.

The construction of the models consisted of 3 main stages. The first was to calculate the values of the independent variables, based on the Lidar data, for 96 circular reference plots within a 9 m radius (254 m²). The radius of the circles, 9 m, was determined to be the most optimal for acquiring Lidar statistics (Olpenda 2018). With the solar radiation values from the reference plots and the values of the independent variables, the 3 solar radiation models mentioned above were built. The final stage was to assess the accuracy of the models. For this purpose, the coefficient of determination R² was calculated, as well as the root mean square error (RMSE) and the mean absolute error (MAE). The above steps were carried out for the 2015 and 2019 reference and ALS data.

14.2.4. Implementation of the solar radiation models

The implementation of the solar radiation models was carried out in several steps. First, a 16 m x 16 m vector grid (256 m² - which corresponds to the radius of ALS characteristics acquisition - 9 m) was generated within the boundaries of the Białowieża Forest area - a total of 2,414,460 objects. The values of the independent variables were then calculated for each grid object. The next step was to calculate the solar radiation values within each object. The final step involved converting the vector grid to a 16 m resolution raster and masking out (removing pixels) gaps and non-forest areas as the solar radiation models only apply to forest stands. Due to the large amount of data to be processed, the processes were automated using the R language. The implementation of the models was carried out in the same way for both the 2015 and 2019 data.

14.3. Results

14.3.1. Reference solar radiation values

The total radiation reaching the forest floor is calculated from the sum of direct and diffuse radiation. For the surveyed plots, in both 2015 and 2019, the average amount of total radiation reaching the forest floor was about 4 moles. The maximum values for each solar radiation component are higher in 2019 (Tab. 14.1). The greatest difference in radiation between the years specified (about 20 and 12 moles), was recorded for the two plots where bark beetle nests were already present in 2015. In contrast, the average difference in total radiation reaching the forest floor between 2015 and 2019 was about 1.9 mol.

Table 14.1. Statistics relating to solar radiation reference values in 2015 and 2019

Statistics	Direct radiation [mol m ⁻² day ⁻¹]		Diffuse radiation [mol m ⁻² day ⁻¹]		Global radiation [mol m ⁻² day ⁻¹]	
	2015	2019	2015	2019	2015	2019
Average	3.43	3.31	0.52	0.51	3.95	3.82
Stan. dev.	2.90	3.52	0.36	0.54	3.23	4.03
Spread	16.99	19.60	2.01	2.60	18.97	22.05
Min	0.51	0.37	0.09	0.14	0.63	0.66
Max	17.50	19.97	2.10	2.74	19.60	22.70

14.3.2. Solar radiation models

According to the methodology described in the subsection *Constructing solar radiation models*, 3 solar radiation models were constructed: direct, diffuse and total. The completed models take the following form:

	Direct radiation
2015	$-1,8571 + (0.2044*LPI) + (0.1287*RH_{mean}) + (7.5213*RH_{DBH_{median}})$
2019	$-1.2489 + (0.2185*LPI) + (0.1019*RH_{mean}) + (-2.2297*RH_{DBH_{median}})$
	Diffuse radiation
2015	$0.1507 + (0.0277*LPI) + (0.0151*RH_{mean}) + (0.8429*RH_{DBH_{median}}) + (-0.0068*R1\%)$
2019	$-0.1054 + (0.0296*LPI) + (0.0041*RH_{mean}) + (-0.0935*RH_{DBH_{median}}) + (0.0024*R1\%)$
	Global radiation
2015	$-1.9440 + (0.2306*LPI) + (0.1416*RH_{mean}) + (8.2668*RH_{DBH_{median}})$
2019	$-1.2555 + (0.2493*LPI) + (0.1061*RH_{mean}) + (-2.3561*RH_{DBH_{median}})$

For the 2015 models, R² accuracy values range from 0.842 for the direct model to 0.877 for the diffuse model. The closer the value is to 1, the more accurate the model. This is checked by comparing the percentage error values, RMSE and MAE. For the direct model, RMSE and MAE are 33.32% and 23.29%, respectively, while for the diffuse model they are 24.28% and 18.38%. For the 2019 models, the R² values are slightly higher, albeit higher MAE and RMSE error values are also observed (Tab. 14.2).

Table 14.2. Accuracy values of solar radiation models

Accuracy metrics	Direct radiation [mol m ⁻² day ⁻¹]		Diffuse radiation [mol m ⁻² day ⁻¹]		Global radiation [mol m ⁻² day ⁻¹]	
	2015	2019	2015	2019	2015	2019
R²	0.842	0.848	0.877	0.898	0.860	0.864
Fitted R²	0.837	0.843	0.871	0.894	0.856	0.860
RMSE	1.144	1.366	0.126	0.170	1.201	1.475
RMSE [%]	33.32	41.29	24.28	33.52	30.38	38.65
MAE	0.799	0.931	0.096	0.112	0.859	1.005
MAE [%]	23.29	28.13	18.38	22.04	21.73	26.35

14.3.3. Deployment of solar radiation models

The final product of the deployment of solar radiation models in the Białowieża Forest area are solar radiation maps created as described in the subsection *Implementation of solar radiation models*. The global solar radiation maps for 2015 and 2019 are shown below (Fig. 14.1).

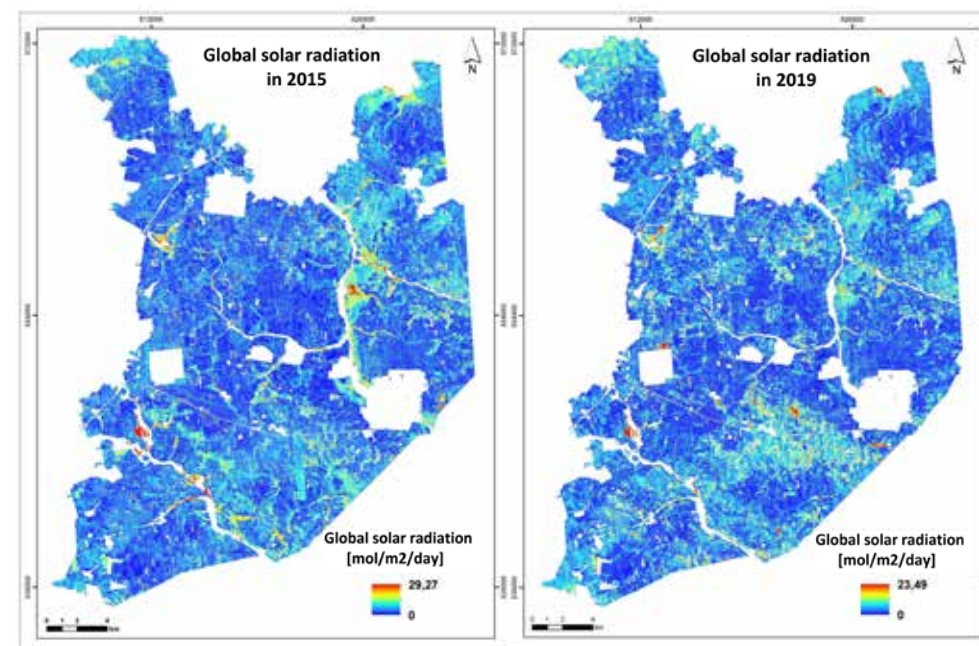

Figure 14.1. Global solar radiation maps for 2015 and 2019

In 2015, the average global solar radiation was 3.13 mol m⁻² day⁻¹, while in 2019 it was higher at 3.26 mol m⁻² day⁻¹. Average values indicate that more sunlight penetrated the stand canopy in 2019.

The 2015 maximum solar radiation value of 29.27 mol m⁻² day⁻¹ is higher than the 2019 value of 23.49 mol m⁻² day⁻¹, but such high values occur in areas of loose canopy cover where solar radiation values may be overestimated. The models were built based on reference plots where stand canopy cover was at least moderate.

14.4. Discussion

The project has repeatedly used airborne laser scanning data for topographic and forest stand analyses. One such analysis was a point cloud study to estimate the amount of solar radiation reaching the forest floor. Studies on the assessment of Lidar variables (characteristics) relevant to solar radiation modelling were carried out as part of a PhD thesis using data from the project (Olpenda 2018). In conducting the tests, out of 18 variables, 4 were selected that significantly influenced the accuracy of the regression model built. The selected statistics were used in the project as independent variables to build multivariate regression models. 3 models each were built as solar radiation components: direct, diffuse and global radiation models, for two data acquisition dates: 2015 and 2019. In doing so, high values of the fit coefficient R^2 in the range 0.842 - 0.898 were achieved. The result of the implementation of the models were maps of the values of solar radiation reaching the forest floor in Białowieża Forest.

There is a strong relationship between sunlight penetrating under the stand canopy and Lidar characteristics (Olpenda 2018). The Laser Penetration Index (LPI), as an indicator of the penetration of laser pulses, has been successfully used in solar radiation research. In the work of Nyman et al. (2017), the R^2 accuracy for a model built on LPI was 0.61. The author points out that this accuracy could be higher with increased accuracy of Lidar data. In contrast, the results of another paper (Bode et al. 2014) present much higher accuracies, with $R^2 = 0.90$ for the direct model and $R^2 = 0.92$ for the global model. In contrast, a relatively low value was obtained for the diffuse model, only $R^2 = 0.31$. Elevation indices (RHmean, RH_{DBH} median) are among the simplest metrics for describing vegetation structure, so they also work well for solar radiation modelling (Olpenda 2018). The R1 index has so far not been used in solar radiation modelling. It was not until Olpenda's (2018) paper that the positive effect of this indicator on increasing the accuracy of the diffuse model was presented. The author also showed that the greater the number of Lidar variables, the more accurate the model. The linear model built on LPI alone achieved satisfactory accuracy ($R^2 = 0.78$ for the diffuse model), but the use of multiple regression with 4 indicators significantly improved its accuracy ($R^2 = 0.83$). The other variables were indices based on laser reflection heights: RHmean and RH_{DBH} median, as well as the quotient index R1 describing the percentage of first reflections.

Over the past few years, many significant changes have taken place in Białowieża Forest. Among these were the dynamics of gaps: appearance, expansion, overgrowth, or stand dynamics, which could be seen in the regeneration and falling of trees. All these factors affect the amount of solar radiation on the forest floor. Therefore, this characteristic should not be interpreted alone. The resulting solar radiation maps should be considered locally, e.g. in the specific stands being analysed. The known characteristics of the analysed area, such as e.g. altitude, dominant species, surroundings, presence or absence of a gap or habitat type, provide some context for the solar radiation values read from the maps. This is particularly important when comparing solar radiation values over certain time intervals. With additional information, it becomes clear why the solar radiation value has increased in one place and decreased significantly in another.

14.5. Conclusion

Aerial laser scanning is a tool that can be used to model values of solar radiation beneath the tree canopy of a large forest complex. In the literature it is identified as a data source that provides information on stand structure, which is essential in the process of estimating light conditions under the canopy. By using this technology, we obtain information on light conditions for a large area in a short period of time as well as information in places that are difficult to access and in areas with different stand conditions. The results are obtained as average daily solar radiation values in $\text{mol m}^{-2} \text{day}^{-1}$.

In this project, 3 solar radiation models were built for 2015 and 2019 data. In the end, solar radiation beneath the forest canopy maps were obtained for both dates. Information regarding the amount of sunlight available can be used, among other things, to characterise the microclimate in a given forest area, to observe forest dynamics in terms of regeneration and to observe changes in the amount of solar energy under the forest canopy between the analysed periods.

The results presented in this paper confirm that airborne laser scanning data can be used in forestry for studies of varying nature and level of detail. Predicting solar radiation in the forest is a task that would be time-consuming and expensive to carry out with only field work.

References

- Anderson M.C. 1964. Studies of the woodland light climate: II. The photographic computation of light conditions. *Journal of Ecology*, 52(3): 643.
- Becker P., Erhart D.W. & Smith A.P. 1989. Analysis of forest light environments part I. Computerized estimation of solar radiation from hemispherical canopy photographs. *Agricultural and Forest Meteorology*, 44 (3-4): 217–232.
- Bode C.A., Limm M.P., Power M.E. & Finlay J.C. 2014. Subcanopy Solar Radiation model: Predicting solar radiation across a heavily vegetated landscape using LiDAR and GIS solar radiation models. *Remote Sensing of Environment*, 154: 387–397. <https://doi.org/10.1016/j.rse.2014.01.028>
- Bonhomme R., Varlet-Grancher C. & Chartier M. 1974. The use of hemispherical photographs for determining the leaf area index of young crops. *Photosynthetica*, 8: 299–301.
- Chianucci F. & Cutini A. 2012. Digital hemispherical photography for estimating forest canopy properties: current controversies and opportunities. *iForest - Biogeosciences and Forestry*, 5 (6): 290-295.
- Comeau P. 2000. Measuring light in the forest (Extension Note 42). Victoria, Canada: B. C. Ministry of Forests.

- Evans G.C. & Coombe D.E. 1959. Hemispherical and Woodland Canopy Photography and the Light Climate. *Journal of Ecology*, 47(1): 103–113.
- Frazer G. W., Fournier R.A., Trofymow J. A. & Hall R. J. 2001. A comparison of digital and film fisheye photography for analysis of forest canopy structure and gap light transmission. *Agricultural and Forest Meteorology*, 109: 249–263.
- Hardy, J. P., Melloh, R., Koenig, G., Marks, D., Winstral, A., Pomeroy, J.W. & Link T. 2004. Solar radiation transmission through conifer canopies. *Agricultural and Forest Meteorology*, 126, (3–4): 257–270.
- Hopkinson C., Chasmer L. 2007. Using discrete laser pulse return intensity to model canopy transmittance. *The Photogrammetric Journal of Finland*, 20(2): 16–26.
- Jennings S.B., Brown A.G. & Sheil D. 1999. Assessing forest canopies and understorey illumination: canopy closure, canopy cover and other measures. *Forestry*, 72(1).
- Jonekheere I., Nackaerts K., Muys B. & Coppin P. 2005. Assessment of automatic gap fraction estimation of forests from digital hemispherical photography. *Agricultural and Forest Meteorology*, 132(1): 96–114.
- Leblanc S. G., Chen J. M., Fernandes R., Deering D. W. & Conley A. 2005. Methodology comparison for canopy structure parameters extraction from digital hemispherical photography in boreal forest. *Agricultural and Forest Meteorology*, 129(3–4): 187–207.
- Macfarlane C., Arndt S.K., Livesley S.J., Edgar A.C., Whit D. A., Adams M.A. & Eamus D. 2007. Estimation of leaf area index in eucalypt forest with vertical foliage, using cover and fullframe fisheye photography. *Forest Ecology and Management*, 242 (2–3): 756–763.
- Mallet C., Bretar F. 2009. Full-waveform topographic lidar: State-of-the-art. *ISPRS Journal of Photogrammetry and Remote Sensing*, 64(1): 1–16. <https://doi.org/10.1016/j.isprsjprs.2008.09.007>.
- Mielcarek M., Kamińska A., Stereńczak K. 2020. Digital aerial photogrammetry (DAP) and airborne laser scanning (ALS) as sources of information about tree height – comparisons of the accuracy of remote sensing methods for tree height estimation. *Remote Sensing*, 12, 1808. DOI: 10.3390/rs12111808.
- Nyman P., Metzen D., Hawthorne S.N.D., Duff T.J., Inbar A., Lane P.N.J. & Sheridan G.J. 2017. Evaluating models of shortwave radiation below Eucalyptus canopies in SE Australia. *Agricultural and Forest Meteorology*, 246: 51–63. <https://doi.org/10.1016/j.agrformet.2017.05.025>.
- Olpenda A.S. 2018. Modeling light conditions in mixed stands using airborne LiDAR data: 1026 Białowieża Forest example, A PhD Dissertation. Warsaw University of Life Sciences 1027 - SGGW, Warsaw, Poland.
- Olpenda A., Stereńczak K., & Będkowski K. 2018. Modeling Solar Radiation in the Forest Using Remote Sensing Data: A Review of Approaches and Opportunities. *Remote Sensing*, 10(5), 694. <https://doi.org/10.3390/rs10050694>.
- Olpenda A., Stereńczak K., Będkowski K. 2019. Estimation of Sub-canopy Solar Radiation from LiDAR Discrete Returns in Mixed Temporal Forest of Białowieża, Poland. *International Journal of Applied Earth Observations and Geoinformation*, 79: 116–132.
- Reitberger J., Schnörr C., Krzystek P. & Stilla U. 2011. 3D segmentation of full waveform LIDAR data for single tree detection using normalized cut. 37.
- Rich P. M. 1989. *A Manual for Analysis of Hemispherical Canopy Photography*. Los Alamos National Laboratory, New Mexico, (LA-11733-M), 92.
- Rich P. M. 1990. Characterizing plant canopies with hemispherical photographs. *Remote Sensing Reviews*, 5 (1): 13–29.
- Rich P. M., Clark D. B., Clark D. A. & Oberbauer S. F. 1993. Long-term study of solar radiation regimes in a tropical wet forest using quantum sensors and hemispherical photography. *Agricultural and Forest Meteorology*, 65(1–2): 107–127.
- Rich P., Wood J., Vieglais D., Burek J. & Webb N. 1999. *Hemiview User Manual 2.1*. Delta-T Devices, Ltd.
- Schleppi P. & Paquette A. 2017. Solar Radiation in Forests: Theory for Hemispherical Photography. In R. A. Fournier & R. J. Hall (Eds.), *Hemispherical Photography in Forest Science: Theory, Methods, Applications*, 28: 15–52. Dordrecht: Springer Netherlands. https://doi.org/10.1007/978-94-024-1098-3_2.
- Soudani K., Trautmann J. & Walter, J.M.N. 2002. Leaf area index and canopy stratification in Scots pine (*Pinus sylvestris* L.) stands. *International Journal of Remote Sensing*, 23: 3605–3618.
- Welles J.M., Cohen S. 1996. Canopy structure measurement by gap fraction analysis using commercial instrumentation. *Journal of Experimental Botany*, 47(9): 1335–1342.
- WinSCANOPY. 2014. *Technical Manual for Canopy Analysis*. Regent Instrument Canada.

15. Identification and mapping of forest communities of the Białowieża Forest using remote sensing data

Jan Marek Matuszkiewicz¹, Rafał Paluch², Adam Szulc²,
Miłosz Mielcarek³, Maciej Lisiewicz³, Łukasz Kuberski²,
Krzysztof Stereńczak³

¹ Faculty of Geography and Regional Studies, University of Warsaw, Krakowskie Przedmieście 30, 00-927 Warsaw, Poland, jm.matuszkiewi@uw.edu.pl

² Forest Research Institute, Department of Natural Forests, 6 Park Dyrekcyjny St., 17-230 Białowieża

³ Forest Research Institute, Department of Geomatics, Sękocin Stary, 3 Braci Leśnej St., 05-090 Raszyn {r.paluch, a.szulc, m.mielcarek, m.lisiewicz, l.kuberski, k.sterenczak}@ibles.waw.pl

Abstract

This publication is the first attempt to delineate the forest communities of the Białowieża Forest and map them on the basis of the latest remote and ground data. The classification of forest communities according to J.M. Matuszkiewicz (2001) was applied, according to which the phytosociological relevés derived from the materials of the natural and cultural inventory of the Białowieża Forest (Gawryś 2016; Czerepko et al. 2021) were identified in terms of actual and potential vegetation. In the process, 12 forest communities with a very diverse representation were recognised, with the lime-oak-hornbeam forest predominating. Available remote sensing data were used for the analysis, including airborne laser scanning, hyperspectral data, and GIS data in the form of a vector habitat map. The accuracy of the map was verified in the field and estimated to be about 70%. Remote sensing methods had the highest accuracy for alder forests, riparian forests and fresh lime-oak-hornbeam forests (more than 85%) and the lowest accuracy for pine forests and mixed pine-oak forests. Low accuracy was found in the case of replacement forest communities on mixed pine-oak forest habitats and the collective heterogeneous group of forest replacement communities LZZ-others. The importance of the input predictors for forest community classification was assessed based on the measurements obtained by the Random Forest algorithm. The 30 most important variables were selected. The most important variables concern the percentage share of pine and alder in the species composition. The remaining variables are characterised by slightly less significance, but the omission of any of them, resulted in a decrease in classification accuracy. The high potential of remote sensing data, i.e. airborne laser scanning and airborne hyperspectral data in the field of phytosociological mapping was confirmed and its limitations were demonstrated. Remote measurement techniques provide good information on the composition and structure of stands. The most important advantages of using remote sensing data are: non-invasiveness, repeatability, efficiency of data acquisition, continuity and coherence of the obtained information and objectivity, while their limitations result from the lack of possibility of sufficient precise recognition of undergrowth species sets in forest communities.

15.1. Introduction

The Białowieża Forest is a unique and very valuable natural object, where long- and short-term ecological research important for understanding natural processes in temperate forest ecosystems has been carried out for a very long time (Paczoski 1930; Matuszkiewicz 1952; Faliński 1986; Sokołowski 2004; Miścicki 2012; Paluch 2015; Jaroszewicz B. et al. 2019; Brzeziecki et al. 2020; Czerepko et al. 2021; Matuszkiewicz et al. 2021). Vegetation surveys, carried out systematically for over 100 years, make an important contribution here. Prof. J. Paczoski was an invaluable and highly respected figure, the „father” of Polish phytosociology, who prepared one of the best known works on Białowieża Forest entitled „Lasy Białowieży” („Białowieża Forests”) (Paczoski 1930). This is a very extensive monograph, presenting not only the concept of „plant sociology” (now phytosociology) and the principles underlying the research and scientific concepts, but also a very detailed description and classification of the phytosociological units of the entire Białowieża Forest during the analysed period (now the Polish and Belarusian parts). Their names changed as the science evolved, and many updates were made, but at the time they laid important foundations for a new science called phytosociology. „Lasy Białowieży” („Białowieża Forests”) is an important and unique work, presenting a picture of the Forest in the 1920s, together with a description of the comprehensive and painstaking research carried out on the research plots. Unfortunately, it is virtually impossible to reconstruct these surveys due to the lack of sufficient locational data.

The next very important stage in phytosociological research carried out in Białowieża Forest was the outstanding monographic study by Prof. W. Matuszkiewicz entitled „Zespoły leśne Białowieskiego Parku Narodowego” („Forest associations of Białowieża National Park”) (Matuszkiewicz 1952). The work describes in great detail the characteristics and development trends of the syntaxonomic units distinguished under natural conditions, while also influencing the development of forestry science. Two years after publishing the characteristics of the BNP complexes, Władysław Matuszkiewicz and his wife Aniela also published the first distribution map of these units in the Park (Matuszkiewicz and Matuszkiewicz 1954). The next group of outstanding researchers of the vegetation of Białowieża Forest evolved from the disciples of Prof. W. Matuszkiewicz, that is, primarily Prof. J. Faliński and Prof. A. Sokołowski, who continued the concepts of their teacher and master. Sokołowski (1993), on the basis of very rich phytosociological material (several thousand phytosociological relevés) and soil and habitat data, made a map of forest associations in the Strict Reserve of Białowieża National Park. However, so far no phytosociological map of forest communities has been drawn up for the entire area of the Polish part of Białowieża Forest. This map is therefore very much needed. As a part of the Life + ForBioSensing project, the development of such a map was planned together with the identification of trees by remote sensing methods, making it one of the most important products of the project. The assumed accuracy of tree identification was above 80%, however, relying only on remote sensing data it is not possible to make a complete identification of the forest communities of the Białowieża Forest, which is characterised by high complexity of stand structure, multi-layering and dynamic changes in species composition. Ground-based phytosociological work was therefore carried out and up-to-date phytosociological material was obtained from other sources to supplement the data. The implementation of the project, the main idea of which concerned

combining remote sensing and ground data and selecting the most optimal remote sensing methods, provides an opportunity to develop a map of the forest communities of Białowieża Forest for the first time. This tool may be used, after repeated surveys, to analyse changes in vegetation. It will also be possible to improve it. This map is part of a monitoring study of the forest stands that complements and backgrounds the intensive changes caused mainly by the spruce bark beetle outbreak. This is because the tree layer is the most important component of a forest community particularly under natural conditions. In order to identify forest communities, it was necessary to recognise the species composition of the lower layers of the stand, the shrubs and above all the undergrowth, which cannot be identified using remote sensing methods.

The main aim of the study was to develop, for the first time, a map of forest communities in the Polish part of Białowieża Forest using available remote sensing data and to specify the methodology for creating the map from these data.

15.2. Materials and Methods

15.2.1. Phytosociological materials for the identification of vegetation units

The basic material for ground-based vegetation characterisation was a set of phytosociological relevés taken as part of the natural and cultural inventory of the Białowieża Forest (Czerepko et al. 2021) conducted by the General Directorate of State Forests successively in 2016-2018 on 1391 permanent plots distributed in a regular network with point distances of 650 m. This project uses a set of relevés from 2018. The circular area of the phytosociological relevés was 4 ares (400 m²). The Braun-Blanquet scale was used to quantify the individual species that make up the community. The geobotanical characteristics of the patch in the form of a phytosociological relevés were created by synthesising phytosociological relevés from spring and summer; it also included phytosociological identification of the current plant community and identification of potential natural vegetation, whereby the phytosociological classification adopted for the inventory was applied (Gawryś 2016), mainly based on the regional view of communities according to A. Sokołowski (1980, 1993, 2004). According to this classification, among the 1391 phytosociological relevés, 26 communities were recognised, some of which were difficult to distinguish, both in the field and in the phytosociological materials, in addition to various forest replacement communities and non-forest communities. For these reasons, the above set of relevés was, within the framework of the present study, subjected to syntaxonomic verification (transition to a simpler syntaxonomic system according to Matuszkiewicz) and selection due to the needs of the applied methods and reduced to the number of 682, constituting the basis for ground-based information on plant communities.

15.2.2. Geospatial and remote sensing data

Three types of spatial data were used in this study: i) airborne laser scanning data; ii) hyperspectral imagery and iii) GIS data in the form of a vector habitat map. The characteristics of the spatial data used are given below:

1) The ALS point cloud was acquired two times: November and December 2015 (scanner: Riegl LMS-680i) and August 2019 (Riegl VQ-780i scanner). A digital terrain model (DTM) was generated from the point cloud acquired in 2015 - a raster with a resolution of 0.50 m was produced using LiDAR points classified as ground (Mielcarek et al., 2020). Based on the generated DTM, the topography of the Białowieża Forest was characterised. ALS data acquired in 2019 were used to estimate selected biometric parameters of the stands (Tab. 15.1).

2) Hyperspectral imagery was acquired in August and September 2019 using a HySpex VS-725 scanner (composed of a set of scanners - two SWIR-384 and one VNIR-1800). Based on the acquired hyperspectral imaging, a species composition map was generated - a raster with a resolution of 2.00 m showing the forest cover by individual tree species, i.e.: birch, oak, hornbeam, linden, alder, pine, spruce and others (Modzelewska et al. 2021).

3) A digital habitat map in vector form was also used in the study. A map depicting the distribution of forest habitat types was developed as part of the work related to the preparation of a forest management plan for the forest districts of Białowieża Forest in 2012. An analogous map of Białowieża NP was not available.

Next, a polygon vector layer was created in the form of a grid of squares with a side length of 50 m, which covered the entire area of Białowieża Forest. In the next step, using spatial relationship, information on habitat, stand and topographic parameters (Tab. 15.1) derived from remote sensing data was assigned to each mesh.

15.2.3. Classification variables

Although some of the machine learning methods are able to handle multivariate data that have a large number of predictors of different data types, the classification accuracy remains relatively unchanged when only the most important predictor variables are used (Millard and Richardson 2013). In this study, the importance of each variable was calculated using the Gini's importance index. Among the variables calculated, some were highly correlated with each other. Pearson's correlation coefficient was used to determine the correlation between pairs of variables. Starting with the most important variable, the highly correlated variables ($r > 0.8$) were gradually removed, leaving a group of the most important and uncorrelated predictors. Table 15.1 shows the variables that were finally selected for the forest community classification.

Table 15.1. Topographic and stand variables used to classify forest communities

Type of variable	Variable	Description	
Topographical	Average terrain altitude [m a.s.l.]	Average height of the terrain in the polygon (50 x 50 m) calculated from a digital terrain model (5.0 m) interpolated from ALS data.	
	Average height from CHM [m]	Average height of trees/objects in the polygon calculated from the Crown Height Model.	
	Slope [degrees]	Average slope of the polygon calculated from the digital terrain model (5.0 m).	
	Aspect (Skidmore 1989)	Cardinal direction (calculations were made for direct and indirect directions: N, N-E, E, S-E, S, S-W, W, N-W) calculated from the digital terrain model (5.0 m). The most frequent value was assigned to the polygon.	
	SWI (Boehner and Selige 2006)	Terrain wetness index representing the potential influence of the terrain topography on hydrologic processes occurring in a given area. Calculated using a digital terrain model (5.0 m).	
	Wind exposition index (Boehner and Antonic 2009)	An index showing how much a particular location is exposed to wind. It is a dimensionless index: values below 1 indicate areas sheltered from wind, and values above 1 indicate areas exposed to wind. Calculated from digital terrain model (5.0 m).	
	Topographic position index (Jennes 2006)		Relative topographic position of individual polygons (mesh) calculated as the difference between the height of a given mesh and the average height of the terrain within a specified neighbourhood. The index was calculated for radius = 200 m based on the digital terrain model (5.0 m). 3 classes were distinguished:
			1 – locations higher than average altitude in the given area (TPI > avg+std.dev)
2 – flat areas with a gradient close to 0 (avg.-std.dev. < TPI < avg.+std.dev.)			
3 – locations lower than the average height in the given area (TPI < avg.-std.dev).			
		The polygon is assigned the value that occurs most frequently in the polygon.	

Tree stand	Proportion of forest habitat types [%]	Percentage of the training area covered by a given forest habitat type (BCF, FMCF, WMCF, FCF, WCF, FMDF, WMDF, FDF, WDF, AF, AAF).
	Proportion of species [%]	Percentage of the polygon area covered by a given tree species (birch, oak, hornbeam, lime, alder, pine, spruce, other deciduous).
	Proportion of trees [%]	Percentage of polygon area covered by trees.
	Average tree height [m]	The average height of trees in a polygon determined by averaging the height of trees (segments) located in a given polygon.
	Number of trees	Number of trees in the polygon calculated based on segmentation (Stereńczak et al., 2020) performed with ALS data.
	Forest structure	Information on vertical structure of stands obtained from ALS data. Two classes of stands were distinguished: single-storey and multi-storey. The class which had larger area share in a given polygon was assigned to the polygon.

15.2.4. Classification and verification method

In order to perform classification for forest community identification, the Random Forest (RF) algorithm was chosen, which belongs to the ensemble methods (Breiman 2001) and is a set of classification trees with binary splits. The basic classification tree algorithm automatically creates a classification tree from training data. In the RF method, a large number of classification trees are created and each tree provides a decision of classification probabilities. The decisions of the test trees are treated as votes and finally the decision with the most votes is determined. Each classification tree is created based on a random sample of n observations taken with return from the training set. At each node of the tree, m variables are randomly selected from M (the total number of variables) and used to find the best distribution. To avoid overfitting the classification model, a 5-fold cross-validation was performed and repeated 20 times. As a result, average classification accuracy rates were obtained. The classification process was performed using the caret package in the R language (R Core Team 2020). Classification accuracy was assessed using the following indices: overall accuracy (OA), Kappa coefficient (κ), producer accuracy (PA) and user accuracy (UA) (Cohen 1960; Story and Congalton 1986). In addition, for data with terrestrial phytosociological diagnosis resulting from field verification of the sampled sites, the F1 index was calculated for each class using the following formula:

$$F1 = \frac{2 * PA * UA}{PA + UA}$$



Figure 15.1. The team of experts during field verification of forest communities (from the left: Rafał Paluch, PhD, Prof. of the Forest Research Institute, Jan Marek Matuszkiewicz, Prof. Adam Szulc, MA) (photo Łukasz Kuberski)

To analyse the accuracy of the automatic classification of forest communities, field verification was carried out on a random sample of 50 m squares. The BF area was divided into 20 equal sub-areas. For the field study, 20 transects of 1300 m length each (covering a sequence of squares) located between adjacent phytosociological relevés were drawn. In total, more than 509 squares were checked for correct remote detection (Fig. 15.1).

In the final stage of the forest community mapping process, the spatial extent of the map was reduced to forest areas. Information from the Forest Digital Map was used for this purpose. The final product of the processing was a map of forest communities in the form of a 50 m resolution raster.

15.3. Results

15.3.1. Identification of forest communities as cartographic units of the map

For this study, a nationwide classification of forest associations much simpler than the original material was adopted, in line with Matuszkiewicz (2001), according to which phytosociological relevés were identified in the field in terms of actual and potential vegetation. In the process, 12 forest associations with very different representations were identified in which the lime-oak-hornbeam forest (*Tilio-Carpinetum*) predominates, which was therefore

divided into two habitat variants: fresh and wet. At the same time, in some cases the identification of the association concerned both the actual vegetation and potential vegetation, and in some cases only potential vegetation (habitat characteristics), because the actual vegetation presented either forest replacement communities (LZZ) or non-forest vegetation. For the further stages of the study, a minimum number of relevés was determined for the categories of the communities to be included in the map, which made it possible to adopt 12 basic categories, i.e. 8 forest associations, including one divided into two variants (as below), and three categories of forest replacement communities, two clearly defined in terms of potential natural vegetation and one collective. These vegetation categories were adopted as the cartographic units of the map produced.

As a result of the analysis of a set of phytosociological relevés, the following natural forest communities (according to Matuszkiewicz 2001) were identified.

1. Fresh pine forests – *Peucedano-Pinetum* (W.Mat. 1962) W.Mat. & J.Mat. 1973
2. Moist pine forests – *Molinio-Pinetum* W.Mat. & J.Mat. 1973
3. Swamp pine forests – *Vaccinio uliginosi-Pinetum* Kleist 1929
4. Mixed oak-pine forests – *Quercus roboris-Pinetum* (W.Mat. 1981) J.Mat. 1988
5. Boreal moist oak-spruce forests – *Quercus-Piceetum* W.Mat. & Pol. 1955
6. Fresh lime-oak-hornbeam forests – *Tilio-Carpinetum* fresh Tracz. 1962
7. Moist lime-oak-hornbeam forests – *Tilio-Carpinetum* moist Tracz. 1962
8. Ash-alder riparian forests – *Fraxino-Alnetum* W.Mat. 1952
9. Alder fen forest – *Ribeso nigri-Alnetum* Sol.-Górn.(1975) 1987

Seven of the above units correspond strictly to association - a hierarchical classification unit of vegetation. For the lime-oak-hornbeam forests, however, the association was internally divided into two ecological forms, grouping the subunits distinguished within *Tilio-Carpinetum* as follows. The subassociations *T-C typicum* and *T-C calamagrostietosum* (for the most part) were classified as fresh lime-oak-hornbeam forests, and *T-C stachyretosum*, *T-C circaetosum*, *T-C caricetosum remotae* and *T-C allietosum* as moist lime-oak-hornbeam forest. The above list includes only those phytosociological units, whose number of relevés was greater than 20. Relevés from communities with a lower number of images were omitted from further analysis. This category included such rare association as: *Sphagno girgensohnii-Piceetum* and *Potentillo albae-Quercetum* and the communities *Quercus robur* – *Carex elongata* and *Betula pubescens* – *Thelypteris palustris*, equivalent to associations.

The forest replacement communities (LZZ) with varying degrees of distortion in stand structure, species composition, and quantitative relationships in the ground layers was also considered in the relevés collection. These communities may have been shaped by forest management (especially felling and planting) or by natural processes such as windthrows or phytophagous outbreaks. When considering this group of communities, their habitat-specific

and dynamic relationships with corresponding natural communities were taken into account by identifying potential natural vegetation. In this respect, two entities were distinguished: LZZ on the habitats of oak-pine forest – *Quercus roboris-Pinetum* and LZZ on the habitats of fresh lime-oak-hornbeam forest – fresh *Tilio-Carpinetum*. Forest replacement communities on various habitats other than the two mentioned above were placed in the category “LZZ_others”. Thus, a total of 12 cartographic units were distinguished and included in the resulting map of forest communities of the Białowieża Forest included in Appendix 7.

Next, a set of relevés was reviewed and a representation of the identified categories was selected. Of the 1391 images analysed, 682 were assigned to one of the 12 forest community categories (Tab. 15.2). This set of relevés represented the phytosociological material from the ground-based survey in the calibration procedures of the real vegetation diagnosis.

Table 15.2. Forest communities in the process of classifying phytosociological relevés

Cartographic unit (forest community)	Number of relevés
<i>Fraxino-Alnetum</i>	79
<i>Molinio-Pinetum</i>	28
<i>Peucedano-Pinetum</i>	36
<i>Quercus roboris-Pinetum (Qr-P)</i>	81
<i>Quercus-Piceetum</i>	25
<i>Ribes nigri-Alnetum</i>	47
<i>Tilio-Carpinetum</i> fresh (T-C)	86
<i>Tilio-Carpinetum</i> wet	88
<i>Vaccinio uliginosi-Pinetum</i>	36
LZZ on the habitats of <i>Qr-P</i>	49
LZZ on the habitats of T-C	105
LZZ on the other habitats	22

15.3.2. Classification results - training data

In classification of the forest communities of the Białowieża Forest, 682 plots were used, which were divided into 12 specific classes (corresponding to the different types of forest communities - see Table 15.2). Table 15.3 shows the overall accuracy of the classification and the accuracy for specific association. The overall accuracy and the kappa coefficient are characterised by a relatively high accuracy of 60.0% and 0.554 respectively, taking into account the intra-class variation and its frequency. It is noteworthy that the classification results are characterised by low variability. The standard deviation of the overall and kappa accuracies were 0.6% and 0.007, respectively. Classification accuracy varied considerably between

classes. The highest producer and user accuracies were found for the *Vaccinio uliginosi-Pinetum* association (81.7% and 71.7%, respectively). On the other hand, the lowest accuracies were found for the LZZ_inne class (7.8% and 33.3%). Forest communities characterised by low abundance were often characterised by low classification accuracy, i.e. *Molinio-Pinetum*, *Quercus-Piceetum* or LZZ_inne.

Table 15.3. Classification accuracies for training data based on a RF classifier. The table includes mean, minimum and maximum measures of accuracy (OA, Kappa, PA, UA) from 20 repetitions. Values in brackets are means with standard deviation

	Avg. (st. dev.)	Min.	Max.
Overall accuracy (OA)	60.0 (0.6)	58.8	61.1
Kappa coefficient	0.554 (0.007)	0.500	0.600
PA_ <i>Fraxino-Alnetum</i>	79.1 (1.7)	75.9	82.3
UA_ <i>Fraxino-Alnetum</i>	63.9 (1.6)	61.4	66.7
PA_ <i>Molinio-Pinetum</i>	40.9 (2.2)	35.7	42.9
UA_ <i>Molinio-Pinetum</i>	44.9 (3.6)	38.7	50.0
PA_ <i>Peucedano-Pinetum</i>	60.1 (3.2)	55.6	66.7
UA_ <i>Peucedano-Pinetum</i>	53.0 (3.0)	47.6	63.2
PA_ <i>Quercus-Piceetum</i>	42.4 (3.3)	36.0	48.0
UA_ <i>Quercus-Piceetum</i>	58.6 (5.0)	52.6	68.8
PA_ <i>Quercus roboris-Pinetum</i>	66.0 (2.3)	61.7	70.4
UA_ <i>Quercus roboris-Pinetum</i>	52.8 (1.7)	48.6	55.7
PA_ <i>Ribes nigri-Alnetum</i>	62.9 (2.9)	57.4	68.1
UA_ <i>Ribes nigri-Alnetum</i>	66.7 (2.1)	63.6	70.5
PA_ <i>Tilio-Carpinetum</i> fresh	75.2 (3.2)	67.4	79.1
UA_ <i>Tilio-Carpinetum</i> fresh	67.0 (1.5)	64.4	69.8
PA_ <i>Tilio-Carpinetum</i> moist	71.6 (1.2)	69.3	75.0
UA_ <i>Tilio-Carpinetum</i> moist	68.0 (1.3)	66.3	71.1
PA_ <i>Vaccinio uliginosi-Pinetum</i>	81.7 (2.1)	77.8	86.1
UA_ <i>Vaccinio uliginosi-Pinetum</i>	71.7 (1.4)	68.3	73.2
PA_LZZ_ <i>Quercus roboris-Pinetum</i>	22.4 (4.0)	14.3	28.6
UA_LZZ_ <i>Quercus roboris-Pinetum</i>	39.3 (4.9)	31.8	48.1
PA_LZZ_ <i>Tilio-Carpinetum</i> fresh	55.1 (2.4)	50.6	60.7
UA_LZZ_ <i>Tilio-Carpinetum</i> fresh	56.7 (2.6)	52.2	61.5
PA_LZZ_others	7.8 (1.8)	5.3	10.5
UA_LZZ_others	33.3 (8.8)	18.2	50.0

The importance of input predictors for forest community classification was investigated. The 30 most important variables were selected (Fig. 15.2). Of all the variables, the percentage of pines and alders in the species composition of a given grid were the most important variables. Although the remaining variables are of lesser importance, omission of any of them resulted in a lower classification accuracy.

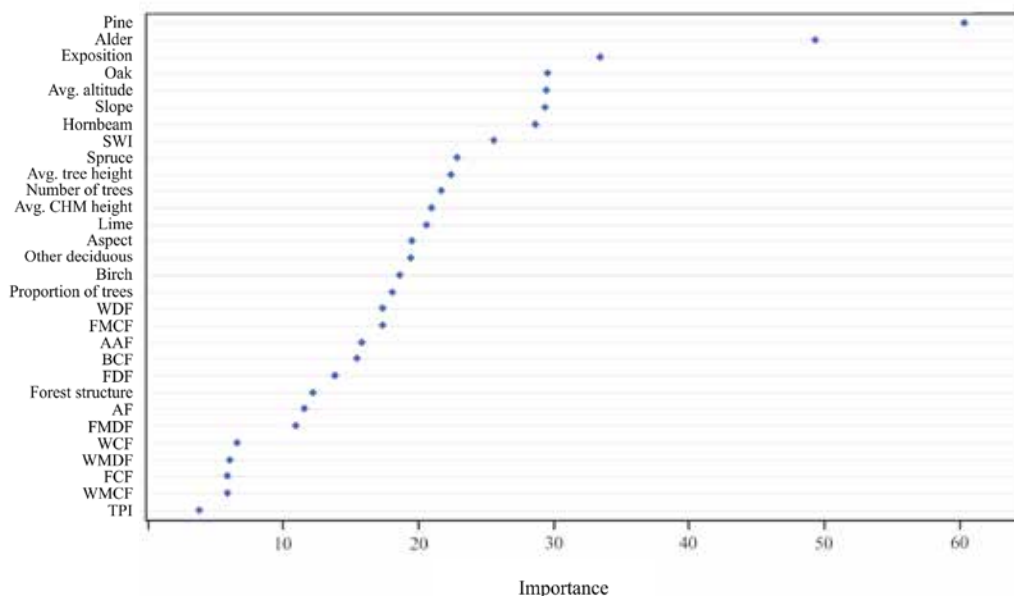

Figure 15.2. The most important variables ranked by Gini importance from the RF algorithm

15.3.3. Classification results - verification data

The average accuracy of forest community determination by remote sensing methods was 0.69 (Tab. 15.4). This value was expressed by the weighted average of the user and producer accuracy parameters (weight - number of objects in the analysed forest community).

Table 15.4. The accuracy of forest community determination based on remote data compared to ground phytosociological diagnosis resulting from field verification of drawn sites (50 m squares)

Forest community	UA	PA	F1	Number of objects
<i>Peucedano-Pinetum</i>	0.33	0.75	0.46	9
<i>Molinio-Pinetum</i>	0.5	1	0.67	6
<i>Quercus robur-Pinetum</i>	0.82	0.43	0.57	34
<i>Tilio-Carpinetum</i> fresh	0.68	0.89	0.77	159
<i>Tilio-Carpinetum</i> moist	0.79	0.57	0.66	71
<i>Ribes nigri-Alnetum</i>	0.94	0.85	0.89	31
<i>Fraxino-Alnetum</i>	0.84	0.74	0.79	58
LZZ <i>Quercus robur-Pinetum</i>	0.03	0.17	0.04	40
LZZ <i>Tilio-Carpinetum</i> fresh	0.82	0.61	0.7	78
LZZ others	0.07	1	0.13	15
Arithmetic mean	0.53	0.64	0.57	502
Weighted average	0.68	0.69		

The highest user and producer accuracy, i.e. the agreement between the remote and the ground-based diagnosis, was characteristic for the alder bog forest (*Ribes nigri-Alnetum*). This is also confirmed by the high value of the F1 index, which is close to 0.9 (Tab. 15.4). Slightly lower accuracy was found for riparian forests (*Fraxino-Alnetum*) and fresh lime-oak-hornbeam forests (*Tilio-Carpinetum* fresh). The F1 values for these classes were 0.79 and 0.77, respectively. The moist lime-oak-hornbeam forest, replacement communities of fresh lime-oak-hornbeam forest and moist pine forest (*Molinio-Pinetum*) were less well distinguished. The other communities analysed (*Peucedano-Pinetum* - fresh pine forests, *Quercus robur-Pinetum* - oak-pine forests) were characterised by below-average accuracy (0.46 and 0.56 respectively). The analysed user's accuracy reached a very low value for the replacement communities of oak-pine forests (0.03) and in the collective category of LZZ_inne (0.07), which collected biased communities of different character. The producer's accuracy was clearly higher here. The summary value of the F1 index, which characterises the accuracy of the communities listed above, also had very small values (0.04 and 0.13). Some relatively rare forest communities, e.g. *Quercus-Piceetum* and *Vaccinio uliginosi-Pinetum*, did not occur in the study sample, so they could not be subjected to the above analyses.

15.4 Discussion

Forests of Białowieża Forest are characterised by a high degree of naturalness, in many areas they are natural or close to natural at the terminal or optimal developmental stage (Sokołowski 2004; Brzeziecki et al. 2020; Jaroszewicz et al. 2020). A relatively small proportion (about 30%) shows features of deformation or undergoes gradual unnaturalisation.

Many forest communities already at the age of about 60-70 years have the "natural" forest features, with the species composition of vegetation of all layers of phytocenosis containing almost all components of old forests (Sokołowski and Paluch 2006; Czerepko et al. 2021). This demonstrates the rapid regeneration of the forest ecosystems of BF arising from both natural and anthropogenic causes. The high naturalness of Białowieża Forest, i.e. the compatibility of species composition and stand structure with the other elements of phytocenosis (as well as, to a large extent, the soil conditions) allowed for an increase in the possibility of using remote sensing data (in particular, remote identification of tree species, their height and other parameters) to map the forest communities of the Białowieża Forest. Nevertheless, the task was demanding, as these forests are characterised by a high complexity of structure, mosaic habitats and dynamic changes caused by the bark beetle. Remote sensing data was used for vegetation analysis from a short time horizon. A typical example of such an activity was the use of data collected in the Life+ ForBioSensing project to create a map of non-forest communities of one of the Białowieża National Park's wild areas (Borkowska 2016). In particular, the high degree of usefulness of orthophotos and digital terrain models was demonstrated here. Remote sensing methods contributed to a significant improvement of the work, as it was possible to reach every place of the analysed area with an accuracy of 0.5 m without the necessity to mark the research area in the field (Borkowska 2016). A much greater challenge is the mapping of forest communities. Studies conducted so far, concerning the use of remote sensing data in mapping forest types and forest communities, point to the high potential of remote data, i.e.: airborne laser scanning and airborne hyperspectral data in the field of vegetation science. Remote measurement techniques are distinguished from ground-based methods by their non-invasiveness, repeatability, efficiency of data acquisition, and continuity and consistency of the acquired information. Moreover, as noted by Pesaresi et al. (2020a) the use of remote sensing makes it possible to separate and distinguish plant communities in an objective manner, thus eliminating one of the biggest drawbacks of the phytosociological method - subjectivity. It is worth noting that methods of plant community classification based on remote sensing data are characterised by relatively high accuracy. Agrillo et al. (2021) developed a methodology in which he obtained the following forest habitat classification accuracies through the integration of different types of data (e.g.: Sentinel-2 images, climatic, topographic data): 91% for evergreen deciduous forests; 76% for coniferous forests; and 68% for deciduous forests. Pesaresi et al. (2020b), on the other hand, reports an accuracy of 87.5% in identifying plant communities (4 community classes are listed) using remote sensing data. The results, obtained in the present work, with a much more in-depth differentiation of forest vegetation into cartographic units, do not differ significantly from those presented by Pesaresi et al. (2020) and Agrillo et al. (2021), which somehow confirms the considerable potential of remote sensing data in mapping forest plant communities.

This publication is the first attempt to map the forest communities of Białowieża Forest on the basis of available remote and ground data. The accuracy of the study was verified in the field and estimated to be around 70%. The designation of some communities e.g. ash-alder, alder and lime-oak-hornbeam forest exceeded 85%. This is satisfactory accuracy. Errors were concentrated in a group of similar communities of pine and oak-pine mixed forests, and especially in the forest replacement communities associated with them, which in the region of north-eastern Poland differ slightly in both ground and remote sensing materials.

15.5. Conclusion

- The application of remote methods made it possible to develop the first map of the forest communities of Białowieża Forest. The accuracy of the study was verified in the field and estimated to be about 70%.
- Remote sensing methods were most accurate for alder, ash-alder and fresh lime-oak-hornbeam forests, and the lowest accuracy for pine and oak-pine mixed forests. Low accuracy was found for the replacement communities of oak-pine mixed forest and the collective heterogeneous group of forest replacement communities LZZ-others.
- The importance of the input predictors for forest community classification was assessed based on the measurements obtained by the RF algorithm. The 30 most important variables were selected. The most important variables concern the percentage share of pine and alder in the species composition. The remaining variables are characterised by slightly less significance, but the omission of any of them, resulted in a decrease in classification accuracy.
- The high potential of remote sensing data, i.e. airborne laser scanning and airborne hyperspectral data in the field of phytosociological mapping was confirmed. The most important advantages of using remote sensing data are: non-invasiveness, repeatability, efficiency of data acquisition, continuity and consistency of the acquired information, as well as objectivity.

References

- Agrillo E., Filippini F., Pezzarossa A., Casella L., Smiraglia D., Orasi A., Attorre F., Taramelli A. 2021. Earth Observation and Biodiversity Big Data for Forest Habitat Types Classification and Mapping. *Remote Sensing*, 13, 1231. <https://doi.org/10.3390/rs13071231>.
- Boehner J., Antonic O. 2009. Land-surface parameters specific to topo-climatology. [In:] Hengl T., Reuter H. [Eds.]: *Geomorphometry - Concepts, Software, Applications. Developments in Soil Science*, 33: 195–226.
- Boehner J., Selige T. 2006. Spatial prediction of soil attributes using terrain analysis and climate regionalisation. [In:] Boehner J., McCloy K.R., Strobl J. (Eds.), *SAGA - Analysis and Modelling Applications. Goettinger Geographische Abhandlungen*, Goettingen: 13–28.
- Borkowska L. 2016. Długoterminowe obserwacje na Uroczysku Reski - wykorzystanie tradycyjnych i nowoczesnych metod badawczych. W: *Aktualny stan Puszczy Białowieżskiej na podstawie wstępnych wyników projektu Life +ForBioSensing* (red. K. Stereńczak, R. Paluch, E. Zin): 81–82.

- Brzeziecki B., Woods K., Bolibok L., Zajączkowski J., Drozdowski S., Bielak K., Żybura H. 2020. Over 80 years without major disturbance, late-successional Białowieża woodlands exhibit complex dynamism, with coherent compositional shifts towards true old-growth conditions. *Journal of Ecology*, 108: 1138–1154. <https://doi.org/10.1111/1365-2745.13367>.
- Breiman L. 2001. Random Forests. *Mach. Learn.*: 5–32.
- Czerepko J., Gawryś R., Mańk K., Janek M., Tabor J., Skalski Ł. 2021. The influence of the forest management in the Białowieża forest on the species structure of the forest community. *Forest Ecology and Management*, 15. <https://doi.org/10.1016/j.foreco.2021.119363>.
- Faliński J.B. 1986. Vegetation dynamics in temperate lowland primeval forests. *Ecological studies in Białowieża Forest. Geobotany*, 8: 1–537. Dr W. Junk Publishers, Dordrecht/Boston/Lancaster.
- Gawryś R. 2016. Przewodnik do oznaczania zbiorowisk leśnych Puszczy Białowieskiej - skrypt opracowany w Instytucie Badawczym Leśnictwa na potrzeby inwentaryzacji przyrodniczej 2016–2018.
- Jaroszewicz B., Cholewińska O., Gutowski J.M., Samojlik T., Zimny M., Latałowa M. 2019. Białowieża Forest—A relic of the high naturalness of European forests. *Forest*, 10, 849. <https://doi.org/10.3390/f10100849>.
- Matuszkiewicz J.M. 2001. Zespoły leśne Polski. Wyd. Naukowe PWN, Warszawa.
- Matuszkiewicz J.M., Affek A.N., Kowalska A. 2021. Current and potential carbon stock in the forest communities of the Białowieża Biosphere Reserve. *Forest Ecology and Management*, 502, 119702. <https://doi.org/10.1016/j.foreco.2021.119702>.
- Matuszkiewicz W. 1952. Zespoły leśne Białowieskiego Parku Narodowego. *Annales UMCS, Sec.C suppl.* 6 p. 218.
- Matuszkiewicz W., Matuszkiewicz A. 1954. Die Verbreitung der Wald Assoziationen des Nationalparks von Białowieża. *Ekologia Polska*, 2(1): 33–60.
- Mielcarek M., Kamińska A., Stereńczak K., 2020. Digital Aerial Photogrammetry (DAP) and Airborne Laser Scanning (ALS) as Sources of Information about Tree Height: Comparisons of the Accuracy of Remote Sensing Methods for Tree Height Estimation. *Remote Sensing*, 12(11):1808. <https://doi.org/10.3390/rs12111808>
- Millard K., Richardson M. 2013. Wetland mapping with LiDAR derivatives, SAR polarimetric decompositions, and LiDAR-SAR fusion using a random forest classifier. *Canadian Journal of Remote Sensing*, 39: 290–307. <https://doi.org/10.5589/m13-038>.
- Miścicki S. 2012. Dynamika naturalnych faz rozwojowych drzewostanów w Białowieskim Parku Narodowym. *Sylvan*, 156(8): 616–626.
- Modzelewska A., Kamińska A., Fassnacht F. E., Stereńczak K. 2021. Multitemporal hyperspectral tree species classification in the Białowieża Forest World Heritage site. *Forestry: An International Journal of Forest Research*, 94(3): 464–476.
- Paczoski J. 1930. Lasy Białowieży. Państwowa Rada Ochrony Przyrody, Monogr. Nauk. 1 p.575
- Paluch R. 2015. Long-term changes of tree species composition in natural stands of the Białowieża Forest. *Sylvan*, 159(4): 278–288. <https://doi.org/10.26202/sylvan.2014083>.
- Pesaresi S., Mancini A., Quattrini G., Casavecchia S. 2020. Mapping mediterranean forest plant associations and habitats with functional principal component analysis using Landsat 8 NDVI time series. *Remote Sensing*, 12, 1132.
- Pesaresi S., Mancini A., Casavecchia S. 2020. Recognition and Characterization of Forest Plant Communities through Remote-Sensing NDVI Time Series. *Diversity*. 12. 313. <https://doi.org/10.3390/d12080313>.
- R Core Team. 2020. R: A language and environment for statistical computing. R Foundation for Statistical Computing, Vienna, Austria.
- Sokołowski A.W., Paluch R. 2006. Wpływ zrębu zupełnego i sztucznego odnowienia sosną na skład roślinności boru świeżego w Puszczy Białowieskiej. *Sylvan*, 150(10): 12–19.
- Sokołowski A.W. 1980. Zbiorowiska leśne północno-wschodniej Polski. *Monographiae Botanicae*, 60: 1–205. <https://doi.org/10.5586/mb.1980.002>.
- Sokołowski A.W. 1993. Fitosocjologiczna charakterystyka zbiorowisk leśnych Białowieskiego Parku Narodowego. *Parki Narodowe i Rezerваты Przyrody*, 12(3): 5–190.
- Sokołowski A.W. 2004. Lasy Puszczy Białowieskiej. Centrum Informacyjne Lasów Państwowych, Warszawa.
- Stereńczak K., Kraszewski B., Mielcarek M., Piasecka Ż., Lisiewicz M., Heurich M. 2020. Mapping individual trees with airborne laser scanning data in an European lowland forest using a self-calibration algorithm. *International Journal of Applied Earth Observation*, 93, 102191.

IV. Summary and suggestions for further actions

16. Monitoring stand dynamics in the Białowieża Forest - possibilities of using remote sensing, based on the results of the Life+ ForBioSensing project

Krzysztof Stereńczak¹

Forest Research Institute, Department of Geomatics, Sękocin Stary, 3 Braci Leśnej St., 05-090 Raszyn
k.sterenczak@ibles.waw.pl

Abstract

Challenges posed by climate change require up-to-date and accurate information on forests. This information can be provided by field measurements or by remote sensing. Having positive and negative aspects, both approaches are mutually complementary. The optimal solution chosen will depend on the objective of the inventory and the scale of the inventoried site.

Firstly, this chapter is an analysis of field and remote sensing data used in the Life+ ForBioSensing project. Secondly, it briefly describes the objective of use of the data and the results obtained. Thirdly, the paper indicates the advantages and drawbacks of field measurements and the application of remote-sensing data for monitoring tree stands' dynamics.

The analyses conducted were a basis to infer conclusions on a potential system for monitoring of the stands' dynamics in the Polish part of Białowieża Forest with the use of remote-sensing data. It was proposed that the data collection and field measurements be performed in a five-year cycle and the results of the Life+ ForBioSensing project be used in these tasks and data processing. Thus, it will be possible to use a large amount of information obtained during the project and treat it as a reference for future analyses of the Białowieża Forest area..

Keywords: monitoring system, remote sensing, forest management, forest conservation

16.1. Introduction

Forest resource inventories using remote sensing data have been conducted for decades (Cochran 1977; Franklin 2001; Kangas and Maltamo 2006). Over the years, the nature of the data and advances in inventory methods have evolved significantly, allowing for very sophisticated analyses and the acquisition of entirely new information. Depending on the data to be used, forest inventory is possible at different scales, from individual trees to entire continents. Monitoring of stand dynamics involves an inventory that is conducted several times for a given area and allows analysis of the directions of changes occurring in a given forest. Forest health has been monitored for several decades using remote sensing data (Wulder et al. 2006). Numerous examples of forest monitoring at different temporal and spatial scales can be found in the literature (White et al. 2005; Senf et al. 2017; Stereńczak et al. 2017, 2019; Grabska et al. 2019).

Each level of remote sensing data collection has its strengths and weaknesses. Analyses conducted primarily with low-resolution satellite data can cover the entire globe. They are essential for analysing global processes, such as changes in the Earth's forested areas or the global carbon cycle in ecosystems (Tang et al. 2019; Zhao et al. 2021). The specificity and nature of global analyses make it impossible to expect high precision on the ground. This is because global analyses are often conducted on a grid of one degree or one square kilometre in size (Santoro et al. 2015). Monitoring at local scales - for example, at the stand, national park, or forest districts - with high-resolution remote sensing data allows for analysis of information about individual trees (Kandare et al. 2017; Stereńczak et al. 2017). This type of analysis is often referred to in the literature as „precision forestry” (Moskal et al. 2009). Such analyses provide information that can be used to manage even the smallest parts of the forest because they are far more detailed than those using low-resolution satellite data. The fundamental disadvantage of analyses that use high-resolution remote sensing data is their cost, which includes acquiring and processing the data. The frequency of repetition of remote sensing data acquisition is often limited primarily by cost.

To properly and best monitor stock dynamics, different types of remote sensing data are often integrated (Fig. 16.1). The most common variant is the merging of structural information and spectral information, i.e., combining the analysis of laser scanning data with the analysis of digital aerial or satellite imagery (Fassnacht et al. 2016; Kaminska et al. 2016). Such integration allows us to maximise the capabilities of remote sensing technologies currently available on the market. A large number of different types of remote sensing data have been described in earlier chapters of this monograph (see Chapters 9–15). Each type of data has its advantages and disadvantages, different acquisition costs, and requirements for the necessary expertise to process the data.

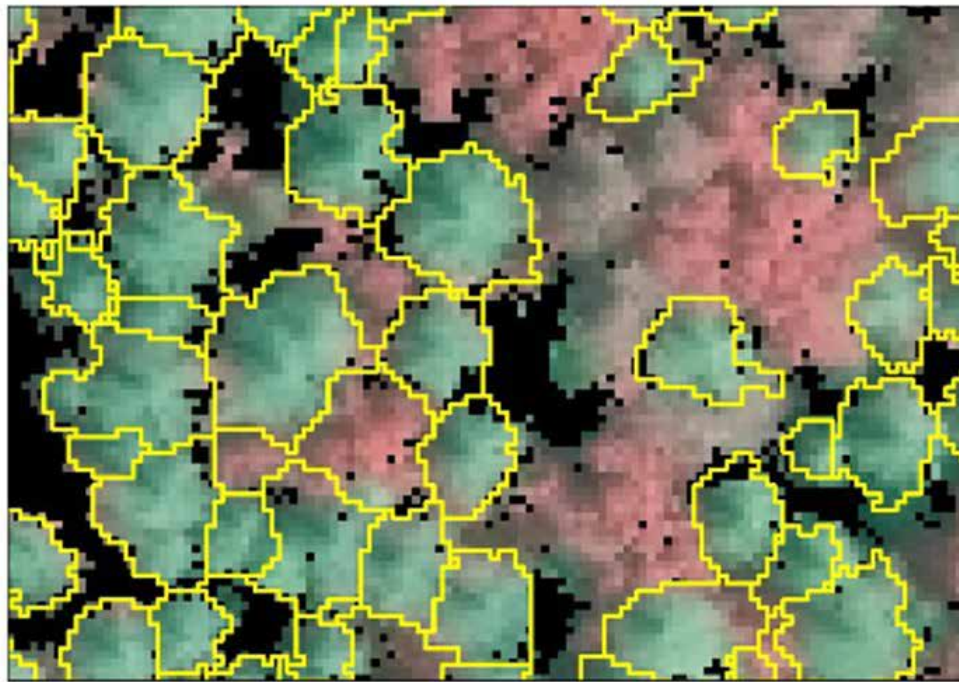

Figure 16.1. Visualisation of an example of Airborne Laser Scanning (ALS) data integrated with colour images in the infrared (CIR, Colour Infrared). The yellow lines mark the area of individual tree canopies identified during the segmentation of the ALS data. Based on the analysis of the CIR images (red and green), only the crowns of dead trees (yellow lines) were classified and their range shown (Source: ForBioSensing)

However, the nature of the data is not the end of the process. Another important issue is the availability of data that can be collected at a later date. A one-time data collection and determination of tree and stand parameters are collectively referred to as an inventory. To say more about what is changing in a stand, information from at least a second inventory is needed, and this - depending on the data - is determined by many aspects. Data can be obtained regularly from satellite platforms, but the fundamental constraint on availability is the frequency of a platform's flights over a given location and the presence of clouds. For flights by aircraft, only budget and weather conditions are constraints on the frequency of data acquisition. For the airborne laser scanning data mentioned above, weather conditions and the presence of clouds are less limiting. However, given the goal of describing forest dynamics, such an analysis should consider what data need to be collected and how often to answer specific questions within the planned budget.

The use of the various technologies is also closely related to their ease of use. Airborne laser scanning data can be acquired virtually around the clock. The only limitation is the occurrence of strong winds and precipitation, as well as the high humidity of the objects to be scanned. All multi- and hyperspectral data can only be acquired during daylight, sunny weather, an appropriate angle of incidence of sunlight, and almost no wind. Thus, the acqui-

sition of these data is subject to significant limitations because the time period over which these data can be acquired is limited, whether it is over a day or over a year. It should also be emphasised that clouds exclude part of the acquisition area from analysis and in extreme cases, when they cover the entire area, prevent any data acquisition. Satellite data are acquired from existing satellites. Actual image acquisition depends primarily on how frequently a satellite passes over a given area of the Earth and whether it is cloud-free. Since satellites also perform military tasks, it sometimes happens that, despite optimal conditions, a satellite performs other, non-civilian tasks while flying over the specified area.

In addition to factors related to technology alone, vertical and horizontal structure, species diversity, and size of a studied forest area are also important components of remote sensing-based forest monitoring (Modzelewska et al. 2017; Grabska and Socha 2021; Ilarionova et al. 2021). Monitoring conventional, species-pure, single-storey plantations with fast-growing trees is obviously an easier task than monitoring forests with a diversified species composition and a multi-storey structure. While in the first case it can be assumed that all trees can be monitored (Leite et al. 2020), in the second case we know that a tree cannot be described in detail under the canopy of the dominant storey. This leads to limitations in the usability of remote sensing in different types of forest ecosystems around the world (Modzelewska et al. 2020, 2021).

Another challenge in monitoring forested areas using remote sensing data is comparing its effects to monitoring conducted using ground-based methods, i.e. using field measurements. Ground-based methods are characterized by greater detail - they describe many characteristics of trees and stands that remote sensing data cannot capture at their current stage of development (Ganivet and Bloomberg, 2019). In contrast, traditional field measurements are typically limited to capturing information in small sample plots that represent only a fraction of the area of the monitoring site (Fig. 16.2). Therefore, statistical methods are used to describe the entire site (see Chapter 4). Thus, sample selection, sample size, and spatial distribution are important for a proper characterization of the entire area under study. In the case of using remote sensing data, we have complete and continuous information about the entire forest area under study.

Using remote sensing data, we can directly determine specific tree or stand characteristics - for example, using ALS (Airborne Laser Scanning) data to measure the height of terrain or trees (Mielcarek 2020) - or create models (relationships) between remote sensing-based auxiliary data and the specified features measured on the ground (Parkitna et al. 2021). In this approach, data obtained from measurements on field-based sample plots are treated as reference data. Using the remote sensing data and the model, the value of a given forest feature can be estimated for the area covered by the data collected in a given acquisition. However, it is not always possible to cover all the characteristics of an individual tree or the characteristics of the lower forest layers with remote sensing data. Comparing the results of an inventory conducted with remote sensing data with the results of a ground inventory is difficult and can only be done on a very limited scale, usually in the area of sample plots established in the field. Several problems are associated with this, such as the fact that trees

belonging to a given sample plot are qualified by the position of the trunk in ground-based measurements, while either the crown or the center of gravity of the tree crown is often used in the analysis of remote sensing data (Miścicki and Stereńczak 2013). Another problem is the different definitions, e.g., for mean height or top height - measured in the field or determined by remote sensing data. It is not always possible to define stand characteristics in the same way for both types of measurements.

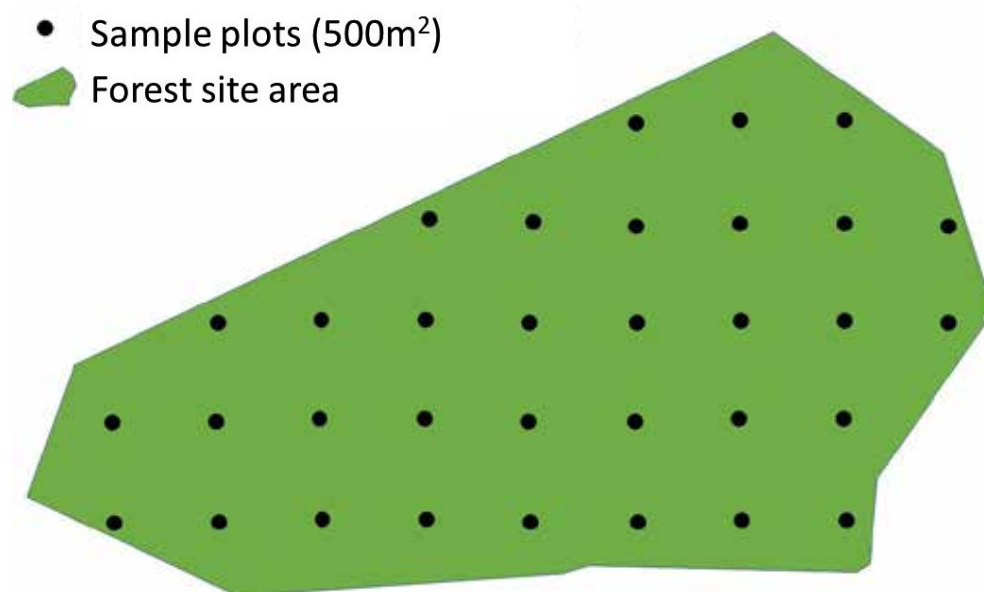

Figure 16.2. Graphical presentation of how multiple characteristics of trees and stands in a forest area are determined in a conventional way (regular grid of sample plots)

Remote sensing data collection platforms have different operability, which affects what area can be photographed/imaged in a certain time in data of a certain type (Fig. 16.3). The least operational are terrestrial remote sensing technologies such as digital images of various types or laser scanners (Terrestrial Laser Scanning [TLS], Mobile Laser Scanning [MLS], Handheld Laser Scanning [HLS], Backpack Laser Scanning [BLS]). In the ForBioSensing project, terrestrial laser scanning was tested. The performance of TLS technology depends largely on the terrain and structure of the forest being inventoried. Among aerial systems, unmanned aerial systems are the least operational. Depending on the type of platform (rotary or fixed-wing), it is possible to collect data for an area of several dozen to several hundred hectares during a single flight lasting up to several dozen minutes. However, conducting flights with unmanned platforms comes with a variety of formal restrictions, so collecting this type of data is not always possible. These platforms are also very sensitive to weather conditions. Systems mounted on aircraft are more operational, as they can collect data over tens or hundreds of square kilometers. The major limitation to the use of aircraft

is weather conditions, which can prevent the execution of a flight that would ensure the collection of data of the specified quality. The most operational satellite systems are those that image thousands of square kilometers of the Earth each day. The higher the level from which the remote sensing data are acquired, the less detailed they are, because if the pixel size of the terrain is too large, it is impossible to determine certain characteristics of the forest stands.

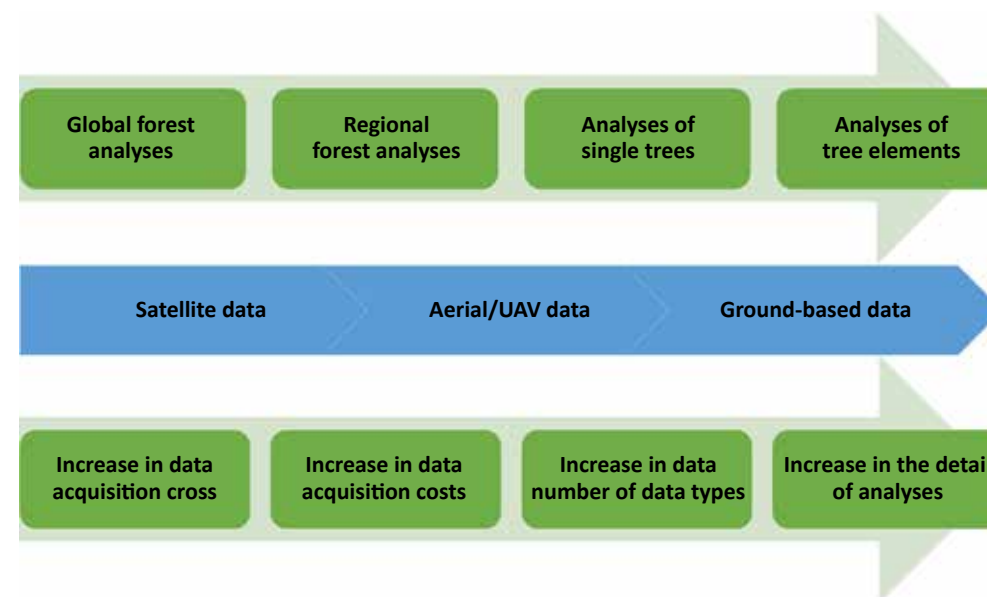

Figure 16.3 The relationship between the level/technology of the remote sensing dataset (blue row) and the area for which the remote sensing data was acquired (top green row) and the challenges faced in processing these data (bottom green row)

The use of remote sensing data in monitoring stand dynamics generally involves the cost of obtaining these data. A special case is monitoring using free satellite data (Shafeian et al. 2021), for example, the Copernicus system. Unfortunately, the number of analyses that can be performed with these data is limited due to their low resolution. When we consider the cost of image data, it depends mainly on its spatial and spectral resolution. In general, the smaller the pixels and the more spectral channels the acquired images have, the higher their cost. In extreme cases, the cost of satellite data can be higher than the cost of conducting a photogrammetric flight over a site.

The Life+ ForBioSensing project collected a set of remote sensing data at different scales and times between 2015 and 2019. The purpose of collecting such a complex set of remote sensing data was to try to answer the question of which of them are best suited, in terms of accuracy and cost, to solve specific analytical and research problems. In the course of the analyses conducted, an answer was sought to the question of which forest monitoring

system should be implemented in the Białowieża Forest in order to optimally manage this valuable natural area.

16.2. The different perspectives on Białowieża Forest

In order to formulate conclusions about how to analyze data on stands in the Białowieża Forest area and what specific processes occur in them, the effects of monitoring using field-based measurements and remote sensing methods were first summarized. Important differences and similarities of the applied methods were pointed out.

16.2.1 The abundance of Białowieża Forest's tree stands

The project determined the volume of living trees in the Polish part of the Białowieża Forest (see Chapters 4 and 9). In 2015, the average volume of forest stands determined based on data from traditionally inventoried monitoring plots was close to 400 m³ ha⁻¹. Remote sensing analyses yielded very similar results, especially in 2015 when the average volume was determined from them to be 405.5 m³ ha⁻¹. In 2019, the average volume of stands in the Polish part of Białowieża Forest was estimated at around 377 m³ ha⁻¹ from remote sensing data and 360 m³ ha⁻¹ based on the field data. The year 2019 saw a difference of less than 5% between the mean volume determined by the two methods. The differences in 2019 may be because not all losses, i.e. dead trees or trees harvested as part of management activities, were correctly recorded with remote sensing data. This is especially true for the lower stand layers, whose changes were not fully mapped with the remote sensing data.

16.2.2 The amount of dead trees and woody debris

The mean amount of dead wood in the Polish Białowieża Forest in 2019, based on ground-based data (see Chapter 6), was 113.2 m³ ha⁻¹ (dead standing trees and down woody debris in total). Between 2015 and 2019, the volume of snag trees determined from field data was 4.173 million m³, of which 2.750 million m³ (66%) was spruce. Similar results were obtained from remote-sensing data, i.e. 4.023 million m³ was the volume of snag trees between 2015 and 2019, of which 2.499 million m³ (62%) was spruce. Approximately 6.7% of the number of trees determined from remote sensing should be added to the values determined from remote sensing data, as this is the amount of bias in determining the number of dead spruce trees (Stereńczak et al. 2020b).

Terrestrial methods make it possible not only to inventory the number of dead standing trees or down woody debris but also to determine the degree of their decay (see Chapters 4 and 6). Unfortunately, the possibilities of inventorying down woody debris using remote sensing data are limited and rarely feasible in a tree stand. It is currently impossible to determine the extent of tree decay using airborne remote sensing technologies employed in the project. Remote sensing data allow the inventory of dead standing trees, as long as their

crowns are large enough to be mapped with data of a specific spatial resolution. The presented results of different measurement methods are very consistent, although they were obtained in a completely different way. The value of dead wood occurrence was estimated for the ground measurements based on a statistical analysis of data from ground monitoring plots. With the help of remote sensing data, the location of individual dead trees was indicated so that, in addition to their total number and volume, their spatial distribution was also presented.

16.2.3 Species composition

To determine the species composition of a given forest site is a challenge both for remote sensing data and terrestrial methods. Remote sensing allows the classification of trees visible from above that are not located in the first storey of a stand. Moreover, without additional height information, it is not possible to assign the found tree species to a given stratum of a tree stand. The remote sensing data also offer limited capabilities of being used in the classification of trees under a stand's canopy. Remote sensing image data generally do provide information on the surface. Ground-based methods using sample plots allow precise identification of species and their volume share. However, these are data that characterise certain limited parts of the area covered (i.e. sample plots), which, in particular for the forest areas with complex structures, may incompletely represent the species composition of a forest community. Based on various data, the shares of the different species in the Polish part of Białowieża Forest in 2015 and 2019 were determined (Tab. 16.1).

Table 16.1. The tabulation of estimated shares of the various dominant tree species in the Polish part of Białowieża Forest determined by terrestrial methods (monitoring plots) and remote sensing methods (hyperspectral data) (see Chapters 4 and 12)

Species	2015		2019	
	Monitoring plots, volume share [%]	Hyperspectral data, area share [%]	Monitoring plots, volume share [%]	Hyperspectral data, area share [%]
Spruce	32	22	20	12
Pine	19	18	23	20
Birch	7	7	7	7
Oak	11	11	14	13
Hornbeam	9	10	11	13
Lime	3	7	3	8
Alder	14	19	17	21
Other	5	6	5	6

The species composition of the Polish Białowieża Forest in 2015 and 2019, determined using terrestrial measurements and remote sensing data, showed slightly different shares of species. On a general level, these data can only be compared to a very limited extent. However, a detailed plot-based comparison carried out as part of the development of a method for using hyperspectral data in species classification showed high agreement between remote sensing classification results and field-based measurements on monitoring plots (Modzelewska et al. 2018).

16.2.4 The comparison of the two perspectives on the analyses of tree stand dynamics in Białowieża Forest

Comparing the possibilities of using data collected traditionally with the use of sample plots and remote sensing data, it should be emphasised that the former provide very accurate and local information on the stand. This is particularly important for the analysis of the young generation, i.e. information on the number of seedlings, the area they occupy, their species composition, their quality and their possible level of damage. None of these data are available for airborne or satellite-based remote sensing platforms. In this respect, airborne laser scanning data can at best allow the detection of lower stand layers (Leiterer et al. 2015), but not the quantification and accurate description of individual young trees. Therefore, it is difficult to draw accurate conclusions about what stands will look like in a few decades based on remote sensing data alone.

A technology that can compensate, to some extent, for the shortcomings of aerial or satellite remote sensing data is terrestrial laser scanning (Krok et al. 2020). In the project, an analysis of single point clouds, acquired from one position located in the center of the sample plots (see Chapters 9 and 10) were performed. The analyses carried out showed the great potential of these data, but at the same time confirmed that in order to be able to speak of an evident added value from the use of these data, scanning should be carried out from several positions on the sample plot area, and the analysis should be carried out after prior detection of individual trees (see Chapters 10 and 11). However, the potential for detecting individual trees is limited and depends on the scan density. Therefore, with the current state of the art and data processing capabilities, it is unlikely that it will be possible to describe the youngest generation of trees with terrestrial laser scanning. Nevertheless, the detection of trees with a breast height ≥ 7 cm is already possible and allows an accurate determination of their biometric characteristics and analyses of interactions between neighbouring trees (Krok et al. 2020).

Remote sensing data allows one to acquire new, previously unavailable information. Among other things, the project team analysed the size and spatial distribution of gaps, the vertical structure of forest stands and determined the amount of solar radiation reaching the forest floor (see Chapters 9 and 14). The information obtained in this way is important for the analysis of stand dynamics, as it provides information on the factors that determine the microclimate in the forest and create favourable conditions for the development of selected tree species (Sapkota et al. 2009; Brzeziecki et al. 2020), thereby indicating the potential for changes in the species composition of the Białowieża Forest stands.

First of all, it should be emphasised that most of the studies presented in this monograph complement other studies. Bringing together different types of field and remote sensing data therefore makes it possible to draw conclusions about the current state of the Białowieża Forest, taking many factors into account. It also allows to indicate possible future changes in the species composition and structure of the forests in this area. By bringing together the above-mentioned data types - in addition to many other studies - it was possible for the first time in history to identify and map the forest communities of the Białowieża Forest using remote sensing data (see Chapter 15).

An important conclusion from the work in this project is that the two perspectives of looking at the forest require a strict definition of the features to be identified and a clear methodology for determining them. If the technology and the approach to describing the forest are changed, a direct comparison of certain results may be prevented (Tab. 16.1, see Chapter 16.2.3). Therefore, it is important to always indicate the source of the forest feature definition and the data used to determine it.

16.3. Monitoring forest dynamics using remote sensing data

As a result of the analyses carried out in the project and based on existing knowledge, individual remote sensing datasets were assessed for their usefulness in identifying selected characteristics of the forest (Tab. 16.2). Taking into account the vastness of the Białowieża Forest, the temporary unavailability of its parts due to the presence of wet habitats and the limited access to some conservation areas, it can be concluded that each remote sensing data resource adds value to conventional monitoring carried out with use of the ground sample plots.

Airborne laser scanning data (ALS) proved to be the most valuable data. They were widely used for estimating stand volume and other stand characteristics, describing vertical structure, gap analysis and also - after segmentation - for monitoring tree mortality, especially of spruce, throughout the Białowieża Forest (Kamińska et al. 2018, 2020, 2021; Stereńczak et al. 2017, 2019, 2020a and 2020b). Importantly, remote sensing data were also used in the classification of species groups (Modzelewska et al. 2020, 2021). In addition, the usefulness of remote sensing data acquired during the leaf-on and leaf-off season were analysed (Kamińska et al. 2018, 2021). The methods developed for processing remote sensing data and the analyses carried out were the project's contribution to the further development of methods for analysing the forest environment.

A point cloud derived from multispectral aerial images was used as a test tool for gap detection and to determine the height of individual trees (Mielcarek et al. 2020). Taking these experiences into account, it can be concluded that the photogrammetric point cloud generalises the shape of tree crowns, does not fully represent the crown area in shaded areas and underestimates the height of individual trees. Therefore, it can replace data obtained from airborne laser scanning to a limited extent. In the case of point clouds derived from

multispectral images (image matching), their utility is increased by the available spectral information that can be used in analyses.

Multispectral airborne data were mainly used to detect dead trees, mainly spruce, in the Białowieża Forest (Stereńczak et al. 2017; Kamińska et al. 2018). An advantage of these data was their high spatial resolution, which allowed easy fusion of these data with tree segments obtained from airborne laser scanning data. As the multispectral data were collected relatively frequently (on average three times per season), monitoring the dynamics of spruce bark beetle outbreaks was possible. The analysis of these data provided important information on the spatial distribution and intensity of the outbreak in the Polish part of the Białowieża Forest.

The multispectral satellite data were initially used in the project to monitor the dynamics of bark beetle outbreak. Unfortunately, during the project it turned out to be impossible to collect three sets of satellite data for the Polish part of the Białowieża Forest in one growing season. Therefore, the project abandoned the use of satellite data in favour of multispectral airborne data. The aspect of satellite data availability is unfortunately often neglected, but it is of great practical importance. Poland is located in an area where about 60% of the days in the year are cloudless. In practise, this means - if we exclude late autumn, winter and early spring - that there are only limited number of days left when it is possible to acquire optical satellite data. Consequently, it can be difficult to acquire data at all, especially for systems with low temporal resolution. In purely theoretical terms, commercially available data from commercial high-resolution satellite systems can provide images of the Earth almost daily like Planet's satellites.

In summary, there are many satellite systems on the market with different capabilities, i.e. with different temporal, spatial, radiometric and spectral resolution. As a rule, the systems that provide data free of charge have low temporal, spatial and spectral resolution. Commercial satellites can take an image of the Earth virtually every day, weather permitting. They can have very high resolution and a large number of spectral channels, but acquisition often involves very high costs.

The hyperspectral data were primarily used in the project primarily for species classification and dead tree detection. The data obtained had a spatial resolution of 2.5 and 5 m, which was a compromise between the data parameters and their cost. It should be objectively stated that hyperspectral imaging was one of the relatively expensive data used in the analysis of the Białowieża Forest within the ForBioSensing project. The application of this type of data on such a large area was the first on the scale of at least Europe. The analyses performed allowed answering some fundamental questions regarding the possibility of using these data in monitoring the species composition in diverse forests of the temperate zone (Modzelewska et al. 2020, 2021) and for monitoring bark beetle outbreak dynamics (Stereńczak et al. 2019). The classification accuracy achieved confirms the usefulness of these data for practical management and protection of forest areas. However, the application of this type of data requires a lot of knowledge and, as for now, a large budget.

Terrestrial laser scanning data was only collected to a limited extent in the project and its analysis was therefore limited to selected aspects (see chapters 10 and 11). Due to the nature of the data collected, it was not possible to use it in its entirety for the analysis of individual trees. It was therefore decided to process the entire point cloud and analyse selected stand characteristics (tree density, volume, basal area). The results obtained showed that even a point cloud acquired from only one position (a single scan) can provide information necessary for the correct quantification of the above-mentioned characteristics and also capture their changes over time. Unfortunately, a major shortcoming of terrestrial laser scanning is that it captures information for a fairly limited area, which makes it very difficult to use on a larger spatial scale. Another difficulty is the limited number of tools suitable for analysing terrestrial laser scanning data.

Table 16.2. Evaluation of the remote sensing material used in the Life+ ForBioSensing project in terms of its usefulness for describing selected forest characteristics (the value 5 means the highest usefulness, 0 means no usefulness)

	Airborne laser scanning (ALS)	Point cloud from aerial images	Aerial multispectral data (RGBIR)	Satellite multispectral data (RGBIR)	Aerial hyperspectral data	Terrestrial laser scanning (TLS)
Stand volume	5	4	2	2	3	2
Other stand characteristics	5	4	3	2	3	2
Species composition	4	2	2	2	5	2
Vertical stand structure	5	2	0	0	2	4
Horizontal stand structure	5	4	3	2	3	4
Tree health condition	4	2	5	4	5	2
Gap detection and analysis of their size	5	4	3	3	3	2

With respect to determine selected tree and stand characteristics, the best data set is the point cloud obtained by using airborne laser scanning (ALS) (Tab. 16.3). Due to current data prices and the density of point clouds, it seems difficult to replace this data in the near future. Our project also confirmed that despite the complexity of the structure of the Białowieża Forest stands, the use of airborne laser scanning data allowed for a variety of analyses and the integration of these data with other data did not produce such a significant improvement in results that it would be worth ordering such data. It would be optimal - in addition to the data from ALS - to acquire aerial photo data from CIR at the same time. The use of these two data sets seems to be the optimal solution for forest stand inventory and monitoring.

An alternative to the ALS cloud in determining stand characteristics can be either a point cloud derived from aerial imagery or hyperspectral data. Point clouds derived from multispectral aerial images can be used in certain areas to describe the structure of the forest and to record selected characteristics of trees and stands (height, density, etc.). Unfortunately, this point cloud does not characterise the stand structure, but only describes the upper layer of the stand, which limits its applications in describing the vertical structure of stands. However, the advantage of the point cloud, is that in addition to geometric information, radiometric information can also be included in the analyses, especially when determining the health status of trees (Kamińska et al. 2018).

Hyperspectral data can be successfully used for species identification and for determining the condition of trees and stands thanks to many spectral channels. The cost of these data determines their practical usefulness, among other things, because they affect their spatial resolution, limiting the accuracy of the analyses carried out.

Terrestrial laser scanning (TLS) data currently have rather limited practical application range, whereas it provides a great potential of scientific research into the aspects of tree architecture, growth and interactions between neighbouring trees. These data will certainly be used on a larger scale when special tools are available that automate their processing and offer the possibility of determining the characteristics of individual trees.

Table 16.3. Indication of the optimal, in terms of accuracy and cost, remote sensing materials used in the Life+ ForBioSensing project in the determination of selected forest characteristics (Airborne Laser Scanning - ALS, images in composition with infrared channel - CIR)

	The optimal and alternative data set for the most accurate inventory	An economically optimal data set that provides reliable information
Stand volume	ALS, ALS+ aerial hyperspectral data	Point cloud from airborne photographs
Other stand characteristics	ALS, ALS + aerial hyperspectral data	Point cloud from airborne photographs
Species composition	aerial hyperspectral data, aerial hyperspectral data + ALS	Multispectral satellite data
Vertical stand structure	ALS	ALS
Horizontal stand structure	ALS	Point cloud from airborne photographs
Tree health condition	ALS+CIR, CIR (from any altitude)	CIR (from any altitude)
Gap detection and analysis of their size	ALS	Point cloud from aerial photographs

There are costs associated with obtaining, verifying and processing remote sensing data. In general, data with higher resolution/density and with greater lateral and forward image overlap are more expensive. In the ForBioSensing project, the average cost of Pléiades satellite data and airborne multispectral data was about PLN 0.9/ha, airborne laser scanning data about PLN 3/ha, and hyperspectral data about PLN 4/ha. When designing a system for monitoring the stands of the Białowieża Forest with the use of remote sensing data, apart from the costs, one should also take into account:

- Who will be the users of the system?
- What know-how characterises the human resources of the institution responsible for carrying out monitoring?
- What are the planned tasks of the system?
- What elements of the forest ecosystem are to be monitored?
- What should be the minimum unit of area, for which the analysis results will be produced (e.g. pixel with a side of 20 m or the stand level)?
- How frequently should the information be provided?
- What is the budget for the project?
- Who will process the data and create maps with the required information?
- How much time will be needed from data collection to delivery of analysis results?

The answers to the above and many other questions will make it possible to plan and carry out forest monitoring properly. In this matter, all the bodies responsible for the management of the Białowieża Forest area should agree and work out an optimal solution that meets their common needs.

16.4. Optimal way of monitoring Polish part of Białowieża Forest

Optimal way of monitoring of Białowieża Forest (Fig. 16.4) could be as follows:

- The inventory would use the regular network of sample plots of the Life+ ForBioSensing project, densified by the State Forests in the natural inventories made in 2016–2018;
- Sample plots should have a minimum area of five ares, although given the size of old trees in Białowieża Forest, plot area should be increased to measure trees with a minimum diameter at breast height of 15 cm on the expanded plots;
- Airborne laser scanning data and aerial CIR data should be collected every 5 years;
- Sentinel satellite data or other free satellite data with a pixel size not larger than that of Sentinel should be continuously analysed;
- If there occurs an outbreak or other disastrous event, high-resolution aerial data or data collected by unmanned aerial vehicle (UAV) could be ordered locally;
- All ground-based data could be collected using the application developed in the Life+ ForBioSensing project (see Chapter 4) and stored in a database;
- Data control and estimation of stand characteristics can be performed with the use of ALSGator program, developed within the REMBIOFOR project and implemented in the State Forests National Forest Holding.

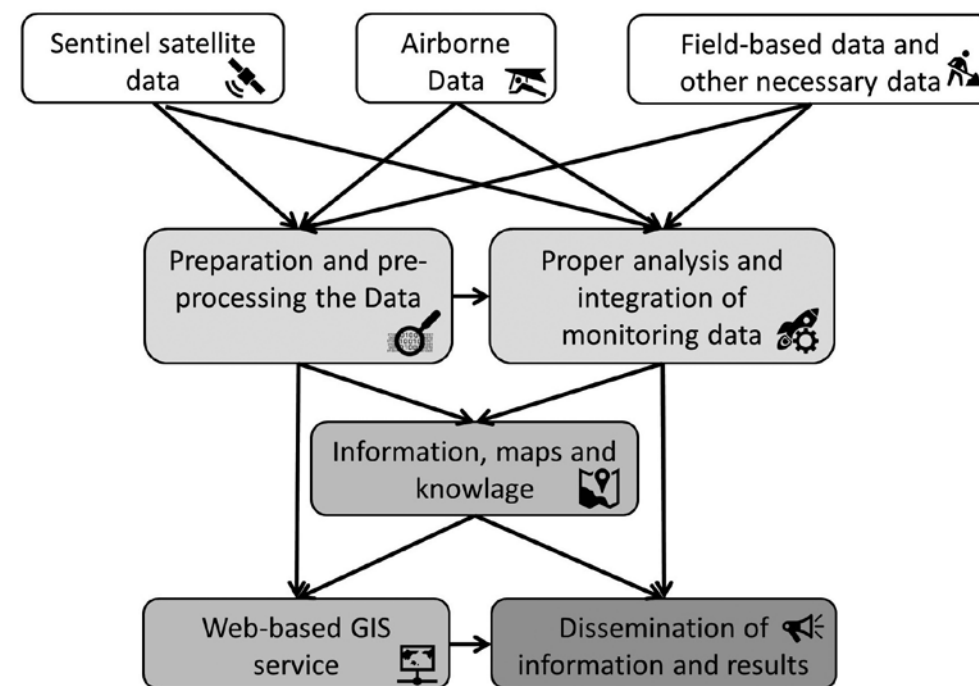

Figure 16.4. Graphical scheme of a possible system for monitoring forest stand dynamics using remote sensing data in the Polish part of the Białowieża Forest

A monitoring system planned in such a way would ensure up-to-date and accurate information on forest stands in the Polish part of the Białowieża Forest, as well as on the direction and dynamics of the changes taking place there. At the same time, such a planned system would make it possible to monitor the process of forest stand regeneration after the largest bark beetle outbreak in the history of the area (Stereńczak et al. 2020b). In addition, the remote sensing monitoring system would fully exploit the impact of the Life+ ForBioSensing project, which initiated the monitoring of the Białowieża Forest stands with the precision of each individual tree visible from above. Given the uniqueness of this area and the data already collected, an important element of monitoring would be the extension of the already existing geoportals created within the Life+ ForBioSensing project. Such a geoportals would, on the one hand, collect all spatial data about the Białowieża Forest in one place and, on the other hand, enable the analysis of changes occurring in this area at the single tree levels.

16.5. Conclusion

The Białowieża Forest is a forest community, which, regardless of its legal status, should be taken care of in a special way since there are few such diversified forest areas in our climatic zone, where natural processes can still be observed. The system for monitoring stands of the Polish part of Białowieża Forest established within the Life+ ForBioSensing project, as well as the developed methods and tools make it possible to continue monitoring this forest at a cost much lower than if it were to be started from scratch. Besides, the project describes in great detail the structure of forest stands since 2015, with particular regard to the effects of the spruce bark beetle outbreaks, so the subsequent inventories would provide data on the dynamics of stands and the directions of changes occurring in them.

The data acquired within the project and the results of data processing were very valuable and provided vast new knowledge. This is evidenced by the fact that data was used in practice almost 80 times, which is confirmed by the licences signed. They also provided new knowledge and contributed to the development of remote sensing based methods of forest analysis. This is reflected in 27 scientific papers with a total impact factor of IF=153 (as of December 2021).

Current climate change, various biotic and abiotic factors that can cause massive trees dieback, and the growing public interest in the condition of forests in Poland require obtaining up-to-date and accurate data. Well-planned monitoring may help face current challenges, as well as prepare the Białowieża Forest management units for future ones.

References

- Brzeziecki B., Woods K., Bolibok L., Zajączkowski J., Drozdowski S., Bielak K. & Żybura H. 2020. Over 80 years without major disturbance, late-successional Białowieża woodlands exhibit complex dynamism, with coherent compositional shifts towards true old-growth conditions. *Journal of Ecology*, 108:1138–1154.
- Cochran W.G. 1977. *Sampling techniques* (3rd Edition). John Wiley & Sons, New York.
- Fassnacht F.E., Latifi H., Stereńczak K., Modzelewska A., Lefsky M., Waser L.T., Straub C., Ghosh A. 2016. Review of studies on tree species classification from remotely sensed data. *Remote Sensing of Environment*, 186: 64–87. <https://doi.org/10.1016/j.rse.2016.08.013>.
- Franklin S. E. 2001. *Remote sensing for sustainable forest management*. Boca Raton, Florida: CRC Press.
- Ganivet E., Bloomberg M. 2019. Towards rapid assessments of tree species diversity and structure in fragmented tropical forests: A review of perspectives offered by remotely-sensed and field-based data. *Forest Ecology and Management*, 432: 40–53.
- Grabska E., Socha J. 2021. Evaluating the effect of stand properties and site conditions on the forest reflectance from Sentinel-2 time series. *PLoS ONE* 16(3): e0248459. <https://doi.org/10.1371/journal.pone.0248459>.
- Ørka H.O., Frizzera L., Næsset E. 2017. Prediction of Species-Specific Volume Using Different Inventory Approaches by Fusing Airborne Laser Scanning and Hyperspectral Data. *Remote Sensing*, 9(5):1–19.
- Illarionova S., Trekin A., Ignatiev V., Oseledets I. 2020. Neural-Based Hierarchical Approach for Detailed Dominant Forest Species Classification by Multispectral Satellite Imagery. *IEEE of Selected Topics in Applied Earth Observations and Remote Sensing*, 14: 1810–1820.
- Kamińska A., Lisiewicz M., Stereńczak K., Kraszewski B., Sadkowski R. 2018. Species-related single dead tree detection using multi-temporal ALS data and CIR imagery. *Remote Sensing of Environment*, 219: 31–43. <https://doi.org/10.1016/j.rse.2018.10.005>.
- Kamińska A., Lisiewicz M., Kraszewski B., Stereńczak K. 2020. Habitat and stand factors related to spatial dynamics of Norway spruce dieback driven by *Ips typographus* (L.) in the Białowieża Forest District. *Forest Ecology and Management*, 476, 118432. <https://doi.org/10.1016/j.foreco.2020.118432>.
- Kamińska A., Lisiewicz M., Kraszewski B., Stereńczak K. 2021. Mass outbreaks and factors related to the spatial dynamics of spruce bark beetle (*Ips typographus*) dieback considering diverse management regimes in the Białowieża forest. *Forest Ecology and Management*, 498, 119530. <https://doi.org/10.1016/j.foreco.2021.119530>.
- Kamińska A., Lisiewicz M., Stereńczak K. 2021. Single Tree Classification Using Multi-Temporal ALS Data and CIR Imagery in Mixed Old-Growth Forest in Poland. *Remote Sensing*, 13, 5101. <https://doi.org/10.3390/rs13245101>.
- Kandare K., Dalponte M., Grabska, E., Hostert, P., Pflugmacher, D., Ostapowicz K. 2019. Forest Stand Species Mapping Using the Sentinel-2 Time Series. *Remote Sensing*, 11, 1197.
- Krok G., Kraszewski B., Stereńczak K. 2020. Zastosowanie naziemnego skanowania laserowego w inwentaryzacji lasu - przegląd wybranych zagadnień. *Leśne Prace Badawcze*, 81(4): 175–194. <https://doi.org/10.2478/frp-2020-0021>.
- Kangas A., Maltamo M. (Eds.) 2006. *Forest Inventory: Methodology and Applications*. Springer, 368 p. ISBN 9781402043819.
- Leite R.V., Silva C.A., Mohan M., Cardil A., Almeida D.R.A.d., Carvalho S.d.P.C.e., Jaafar W.S.W.M., Guerra-Hernández J., Weiskittel A., Hudak A.T., Broadbent E.N., Prata G., Valbuena R., Leite H.G., Taqueti M.F., Soares A.A.V., Scolforo H.F., Amaral C.H.d., Dalla Corte A.P., Klauber C. 2020. Individual Tree Attribute Estimation and Uniformity Assessment in Fast-Growing Eucalyptus spp. Forest Plantations Using Lidar and Linear Mixed-Effects Models. *Remote Sensing*, 12, 3599. <https://doi.org/10.3390/rs12213599>.
- Leiterer R., Torabzadeh H., Furrer R., Schaepman M.E., Morsdorf F. 2015. Towards Automated Characterization of Canopy Layering in Mixed Temperate Forests Using Airborne Laser Scanning. *Forests*, 6: 4146–4167. <https://doi.org/10.3390/f6114146>.

- Mielcarek M., Kamińska A., Stereńczak K. 2020. Digital aerial photogrammetry (DAP) and airborne laser scanning (ALS) as sources of information about tree height - comparisons of the accuracy of remote sensing methods for tree height estimation. *Remote Sensing*, 12, 1808; <https://doi.org/10.3390/rs12111808>.
- Miścicki S., Stereńczak K. 2013. Określanie miąższości i zagęszczenia drzew w drzewostanach Centralnej Polski na podstawie danych lotniczego skanowania laserowego w dwufazowej metodzie inwentaryzacji zapasu. *Leśne Prace Badawcze*, 74(2): 127–136. <https://doi.org/10.2478/frp-2013-0013>.
- Modzelewska A., Stereńczak K., Mierczyk M., Maciuk S., Bałazy R., Zawila-Niedzwiecki T. 2017. Sensitivity of Vegetation Indices in Relation to Parameters of Norway Spruce Stands. *Folia Forestalia Polonica, Series A – Forestry*, 59(2): 85–98.
- Modzelewska A., Fassnacht F.E., Stereńczak K. 2020. Tree Species Identification within an extensive forest area using airborne hyperspectral data. *International Journal of Applied Earth Observations and Geoinformation*, 84, 101960. <https://doi.org/10.1016/j.jag.2019.101960>.
- Modzelewska A., Kamińska A., Fassnacht F.E., Stereńczak K. 2021. Multi-temporal hyperspectral tree species classification in the Białowieża Forest World Heritage site. *Forestry: An International Journal of Forest Research*, cpaa048, <https://doi.org/10.1093/forestry/cpaa048>.
- Moskal L.M., Erdody T., Kato A., Richardson J., Zheng G., Briggs D. 2009. Lidar Applications in Precision Forestry. *Proceedings of SilviLaser*, 11: 154–163.
- Parkitna K., Krok G., Lisańczuk M., Mitelsztedt K., Ukalski K., Magnussen S., Markiewicz A., Miścicki S., Stereńczak K. 2021. Modelling growing stock volume of forest stands with the use of selected LiDAR Area Based Approaches in various predictive models. *Forestry: An International Journal of Forest Research*, cpab011. <https://doi.org/10.1093/forestry/cpab011>.
- Santoro M., Beaudoin A., Beer C., Cartus O., Fransson J.E., Hall R.J. et al. 2015. Forest growing stock volume of the northern hemisphere: Spatially explicit estimates for 2010 derived from Envisat ASAR. *Remote Sensing of Environment*, 168: 316–334.
- Senf C., Seidl R., Hostert P. 2017. Remote sensing of forest insect disturbances: Current state and future directions. *International Journal of Applied Earth Observation and Geoinformation*, 60: 49–60.
- Sapkota I.P., Tigabu M. & Odén P.C. 2009. Species diversity and regeneration of old-growth seasonally dry *Shorea robusta* forests following gap formation. *Journal of Forestry Research*, 20: 7–14.
- Shafeian E., Fassnacht F.E., Latifi H. 2021 Mapping fractional woody cover in an extensive semi-arid woodland area at different spatial grains with Sentinel-2 and very high-resolution data. *International Journal of Applied Earth Observation and Geoinformation*, 105: 102621.
- Stereńczak K., Kraszewski B., Mielcarek M., Piasecka Ż. 2017. Inventory of standing dead trees in the surroundings of communication routes – The contribution of remote sensing to potential risk assessments. *Forest Ecology and Management*, 402: 76–91. <https://doi.org/10.1016/j.foreco.2017.07.018>.
- Stereńczak K., Mielcarek M., Modzelewska A., Kraszewski B., Fassnacht F.E., Hilszczański J. 2019. Intra-annual *Ips typographus* outbreak monitoring using multi-temporal GIS analysis based on hyperspectral and ALS data in the Białowieża Forests. *Forest Ecology and Management*, 442: 105–116.
- Stereńczak K., Kraszewski B., Mielcarek M., Piasecka Ż., Lisiewicz M., Heurich M. 2020a. Mapping individual trees with airborne laser scanning data in an European lowland forest using a self-calibration algorithm. *International Journal of Applied Earth Observations and Geoinformation*, 93, 102191. <https://doi.org/10.1016/j.jag.2020.102191>.
- Stereńczak K., Mielcarek M., Kamińska A., Kraszewski B., Piasecka Ż., Miścicki S., Heurich M. 2020b. Influence of selected habitat and stand factors on bark beetle *Ips typographus* (L.) outbreak in the Białowieża Forest. *Forest Ecology and Management*, 459, 117826. <https://doi.org/10.1016/j.foreco.2019.117826>.
- Tang H., Armston J., Hancock S., Marselis S., Goetz S., Dubayah R. 2019. Characterizing global forest canopy cover distribution using spaceborne lidar. *Remote Sensing of Environment*, 231, 111262.
- White J.C., Wulder M.A., Brooks D., Reich R., Wheate R.D., 2005. Detection of red attack stage mountain pine beetle infestation with high spatial resolution satellite imagery. *Remote Sensing of Environment*, 96: 340–351. <https://doi.org/10.1016/j.rse.2005.03.007>.
- Wulder M.A., Dymond C.C., White J.C., Leckie D.G., Carroll A.L., 2006. Surveying mountain pine beetle damage of forests: A review of remote sensing opportunities. *Forest Ecology and Management*, 221: 27–41. <https://doi.org/10.1016/j.foreco.2005.09.021>.
- Zhao J., Xie H., Ma J., Wang K. 2021. Integrated remote sensing and model approach for impact assessment of future climate change on the carbon budget of global forest ecosystems. *Global and Planetary Change*, 203: 103542.

17. Dissemination of ForBioSensing results

Wirginia Duranowska¹, Damian Korzybski², Krzysztof Stereńczak²

¹ Forest Research Institute, Scientific Information and Promotion,
Sękocin Stary, 3 Braci Leśnej St., 05-090 Raszyn

² Forest Research Institute, Department of Geomatics,
Sękocin Stary, 3 Braci Leśnej St., 05-090 Raszyn
{w.duranowska, d.korzybski, k.sterenczak}@ibles.waw.pl

Abstract

This chapter describes the activities that have been planned and carried out within the project in order to disseminate the results of the project. All the communication channels used, both direct and indirect, have been characterised. The dissemination of the project was carried out using tools such as the project website, social media, TV programmes, radio programmes, dissemination films, face-to-face meetings, leaflets, book publications, project gadgets, calendars, T-shirts, scientific publications. During the 6 years of the project, dissemination activities using indirect communication tools have reached at least 5 million documented recipients. Using direct communication tools, information about the project was presented to nearly 15,000 recipients at 134 different meetings. The insights described in this chapter may be useful for other Beneficiaries embarking on projects co-financed by the LIFE Programme.

Keywords: project promotion, project communication, social media

Introduction

In the ForBioSensing project and in accordance with the policies of the European Union and the objectives of the LIFE+ project, extensive promotion of the activities and results of the project were planned to be conducted. European Union citizens have the right to know how the EU's financial resources are being used and the results obtained as a result. The EU therefore requires that the public (and all recipients of project results), as well as individuals and entities participating in it, be informed of any progress in the project. The ForBioSensing project has carried out a number of promotional activities that were planned as part of the application submitted for the project. These have been defined and parameterised in a dedicated section of the proposal, where appropriate indicators for specific tasks are identified. The aim of the chapter is to present the methods and techniques used for dissemination of the ForBioSensing project within the framework of its promotional activities and to present the measurable effects of these activities which were achieved (according to the Beneficiary - very high). The ForBioSensing team would like to share their experiences of the activities carried out to promote the project. The methods presented for dissemination may provide inspiration to Beneficiaries who take up the challenge of running a project co-financed by the LIFE Programme.

While performing promotional activities for ForBioSensing, a number of dissemination activities were undertaken, ranging from obligatory activities, such as: the project website, use of promotional logos on project documents and setting up information boards, to non-obligatory activities, such as: displaying information boards in the headquarters of supporting organisations, roll-ups - visible at stands during events in which project staff participated, or promotional films, available on the Internet and screened at conferences and lectures. ForBioSensing also appears in many other audio and visual forms of promotion. Project promotion consists of three components: the knowledge to be promoted, the media to be used for promotion, and face-to-face meetings with different stakeholders that were interactive in nature (Fig. 17.1).

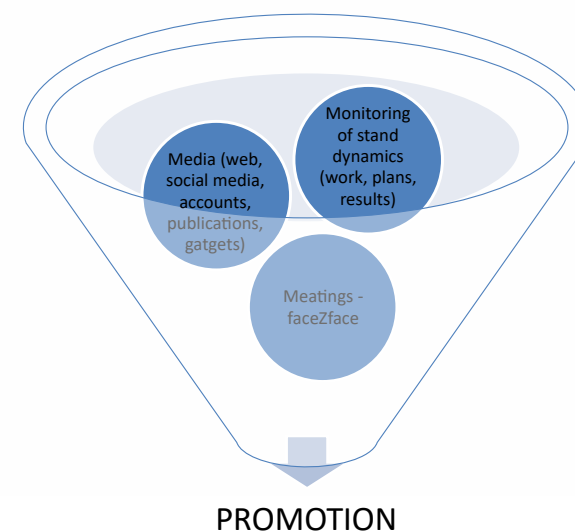

Figure 17.1. Components of the promotion of the ForBioSensing project

All project-related communication (work, plans, results) conveyed through mass media and other information vehicles is called **indirect communication**. With this form of communication in the project, the following promotional indicators were achieved:

1. Creation of information boards (Fig. 17.2), which were placed in the headquarters of the FRI (Sękocin Stary and Białowieża), the headquarters of the Stakeholders: Białowieża National Park and Forest Districts, and in the area near the project site. Installation of information boards about the project in Białowieża Forest, apart from the obligatory placement of boards in the Beneficiary's headquarters, were installed in popular places, both among tourists visiting the forest and people living in the surrounding areas. A total of 10 boards were installed in the following locations: Białowieża Forest District (Stara Białowieża wilderness, Jagiellonian Forest Education Centre, Bison Show Reserve), Hajnówka Forest District (the starting station

of the narrow-gauge forest railway, the area of the Forest District's headquarters), Browsk Forest District (Świnoroje wilderness), Białowieża Municipality (car park on ul. Kolejowa), ZLN in Białowieża (in front of the ZLN building in Białowieża, a plaque hanging inside the building), FRI in Sękocin Stary (a plaque on the grounds of the FRI in Sękocin Stary, a plaque hanging inside the FRI main building).



Figure 17.2. Information board for the ForBioSensing project Source. FBS

2. Production of films disseminating the activities of the project. The purpose of the films was to show the growth of the forest, specifically the growth and development of the forest's trees. Techniques for collecting images over long periods of time were used to create dynamic images from single frames documenting the processes of tree growth in the forest. The films were used to promote the project and made available online, where they gained a wide range of fans and viewers. Productions (films, spots, reports from meetings), were made at multiple stages of the ForBioSensing team. Thus, the audience can learn about the stands of the Białowieża Forest as seen from the perspective of a scientist, a naturalist and also a field worker. The richness of the forest landscape and the surrounding biodiversity step by step, helps to answer one of the most important questions formulated in the project: "How does the forest change?". The films were broadcast on regional television. In addition to their obvious promotional role, they have become a good way of informing the local community

about the LIFE+ programme and the results of the project. Since the launch of the ForBioSensing project, the following film productions have been made:

- "Życie drzewa" ("The Life of a Tree", prod. Parkos Media) - shows in an accessible way how many functions a tree has. It protects biodiversity, provides oxygen, and provides people with wood.
- A series of films entitled. "Poznać Puszcę Białowieską" ("Getting to Know Białowieża Forest", prod. Parkos Media). Thanks to these films the audience can learn about the idea and goal of the project, find out more about the methods used during its implementation to remotely observe the forest, as well as get a glimpse into the daily work of the field team.
- "Las się zmienia!" ("The forest is changing!"; prod. Parkos Media), where a summary of the work carried out over 6 years of the project was presented. The specifics of the use of remote sensing in forestry are outlined, and the results of the work are presented - along with the purposes for which ForBioSensing data can be used and is already being used.

All productions can be viewed via the YouTube platform: https://www.youtube.com/channel/UC9aRcGf_wZs8GpnPg0Cikmg/videos

A particularly impressive production, showing the forest ecosystem in a non-standard way, in the absence of any human presence, is the film "Życie drzewa" („The Life of a Tree”). This form of depicting nature was appreciated by professional artists. We are proud to present the award received by the creators of the production created for the ForBioSensing project. The award was given in the 'educational film' category. During the online edition of the XVIII W. Puchalski International Nature Film Festival in Łódź, which took place from 22-25 September 2020, 29 excellent productions from different parts of the world, including: Serbia, Iran, Germany, the Netherlands and Belgium, competed against each other.



Figure 17.3. Parkos representatives, prize winners of the 18th INFF Award for the film „Życie drzewa” („The Life of a Tree”) Source. I. Prokopiuk

Excerpts from the film were broadcast on 5 November 2020 on Teleexpress (Fig. 17.4). The programme highlights that trees are home to many species of animals and their wildlife value increases with age.

05.11.2020, 17:00

publikacja: 05.11.2020, 17:00



Figure 17.4. Excerpt from a film broadcast on Teleexpress. Source. TVP



Figure 17.5. The cover of the 2020 project calendar. Source. FBS

3. Publication of this, bilingual publication on the forest stands of Białowieża Forest. Visually and substantively appealing, the publication aims to describe the changes taking place in the forest over a broad period of time. This summarised the results. The project has accumulated unique material and a wealth of new knowledge. The book will be distributed free of charge, part of the print run will be donated to the FRE library, the BNP collection as well as local libraries.
4. Preparation and printing of 12-page A2 calendars (Fig. 17.5). One of the annual activities of the ForBioSensing project was the publication of the project calendar. Preparing and printing calendars is a very practical method of promotion. On every subsequent page you can see not only beautiful pictures of the forest, but also the effects of the work resulting in subsequent years of the project. With the introduction of digital imaging maps and visualisations, the calendars in subsequent years became dominated with presentations of the results. The ForBioSensing calendars reached over 600 people each year. docierały corocznie do ponad 600 osób.

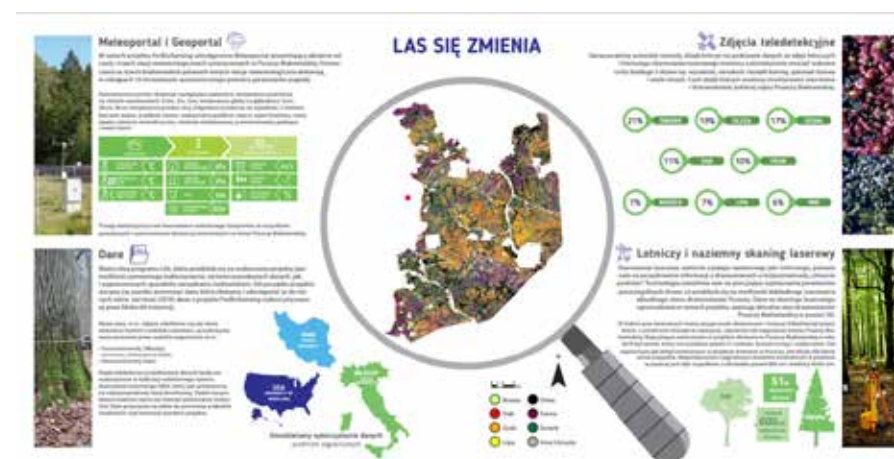

Figure 17.6. Extract from an FBS leaflet. Source. FBS

- T-shirts with the project logo and the logo of the LIFE+ financial instrument were distributed at meetings, mainly in schools and during conferences. 1700 pieces were produced. (2 edition - 850 each). The graphics that appeared on them were designed by a 14-year-old volunteer, Dominika (Fig. 17.7). Her work depicts the fieldwork carried out as part of our project.



Figure 17.7. Project T-shirts. Source. FBS

- Production and broadcast of a series of five radio programmes on regional radio stations. The aim of the broadcasts was to present the aims and effects of the project and to enable radio listeners to take an active part in discussing the issue. The broadcasts were hosted by Polskie Radio Białystok, and the final results can be heard on the website, under the broadcasts ("audycje") tab: <https://www.radio.bialystok.pl/ekosfera/index/id/150434>.
- Scientific publications. The expertise and commitment to the research work of the ForBioSensing team as well as the scientific teams collaborating with them, has resulted in publications, presentations and conference reports over a number of years. We provide access to the scientific publications produced so far in the project. There are also publications on the use of geoinformatics in forestry, such as stand health assessment, species identification and the determination of individual tree characteristics. In the link below there is a list of publications. We sincerely encourage you to read them.: <http://www.forbiosensing.pl/publikacje-naukowe>. In summary, at the end of 2021, the project has produced 27 scientific papers with a total IF of 153 and a total number of ministerial points of 3109. Papers were published, among others, in the following scientific journals: Nature, Nature Communication, The Proceedin-

gs of the National Academy of Sciences, Remote Sensing of Environment, Forest Ecology and Management, International Journal of Applied Earth Observations and Geoinformation, Nature Scientific Data, Remote Sensing, International Journal of Remote Sensing, Forestry: An International Journal of Forest Research and Forests. In addition, more than a dozen popular scientific studies and monograph chapters have been written.

- Layman's report. This publication provides information about the project for a non-naturalist audience. This report describes the main tasks of the project - objectives, activities and results. It was compiled at the end of the project, in Polish and English.
- Visual identity of the project (Fig. 17.8). All forms of promotion: the planned activities and results obtained in the project, within the LIFE+ ForBioSensing project, bear the project's visual identity. This means that the promotional products created, among others: exhibition of information boards, rollups, promotional films, leaflets, etc., contain the following logos: LIFE+, NFOŚiGW, FRI (IBL) and the logo of the ForBioSensing project, as well as: the name of the project, the contract number, information about the sources of financing for the project. All these help to clearly identify the ForBioSensing project.



Figure 17. 8. Cover of a ForBioSensing project leaflet. Source. FBS

11. Up-to-date information about project activities on the website and social media accounts. Another promotional activity was to maintain and update information on the project on an ongoing basis and publish it on the project website and social media accounts. These activities include accounts and tools such as:

- Keeping the project website up to date: www.forbiosensing.pl
- Keeping project profiles updated on social media: Facebook, Twitter, Instagram, YouTube channel.
- Maintaining a web service (Meteoportal) presenting the current status of several meteorological parameters registered on an ongoing basis in three locations of Białowieża Forest. The page can be accessed at: <http://www.forbiosensing.pl/meteoportal>.

Website. A constantly updated project website, containing information on the project's assumptions and objectives, source of financing, progress in the implementation of the project's objectives and activities - is the best way to promote the project due to its widespread availability. The website repeatedly updates the public on key project developments, planned activities, meetings and data transfer. Since the start of the project, the content on the website has received 164,482 page views.

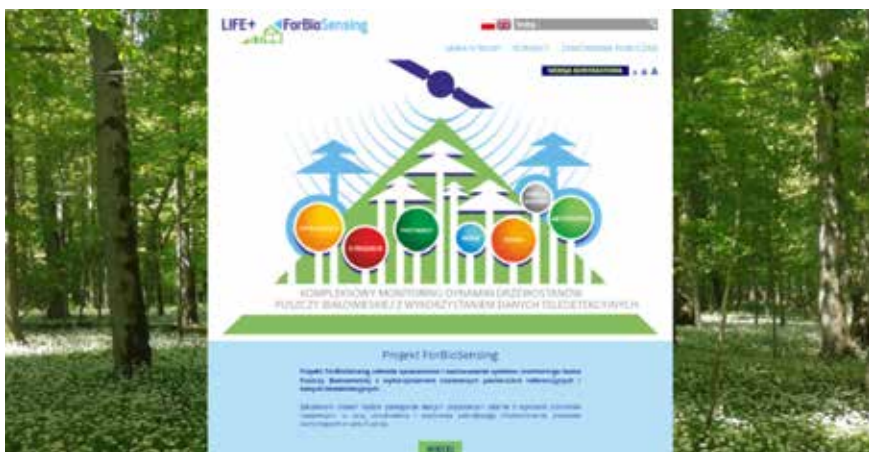

Figure 17.9. ForBioSensing project website. Source. FBS

Facebook. This is one of the media outlets with the largest audience reach. It has its regular readers (so-called fans) who periodically like and share published content. Over the past few years, the project's fan page www.facebook.com/forbiosensing has created a regular series of posts about the daily work of the project team and depicting the forest's wildlife. Regular posts include the series:

- Our activities in the forest (day-to-day work of the team, field activities);
- From the ForBioSensing video library (the latest film productions, events and viral videos produced by the project);
- Appreciating biodiversity (forest wildlife, colourful descriptions of plants and animals, corresponding to the season).

These series caused the fan page to start growing in popularity at a rapid pace.



Figure 17.10. Growth in fan page likes since 2018. Source. FBS

A particularly good period of increased popularity of posts on the ForBioSensing fan page was the turn of 2018 and 2019. Posts achieved a reach of 31,337 in February 2019.

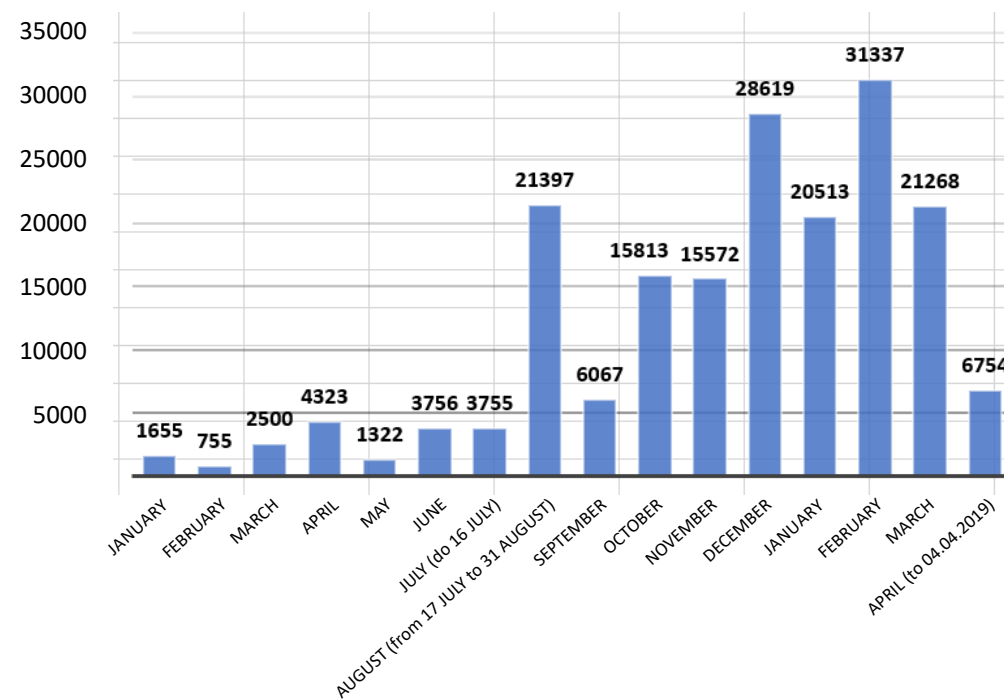

Figure 17.11. Post reach in 2018/2019. Source. FBS

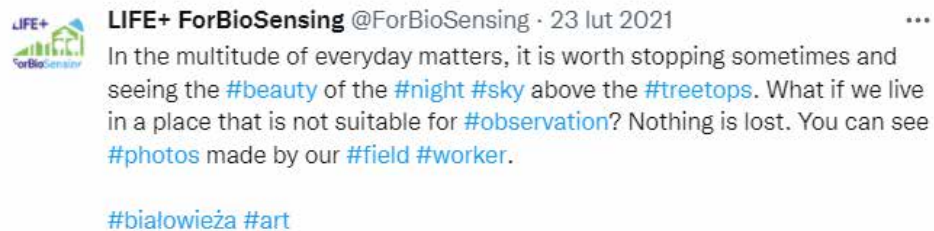

Figure 17.12. Update from Twitter account. Source. FBS

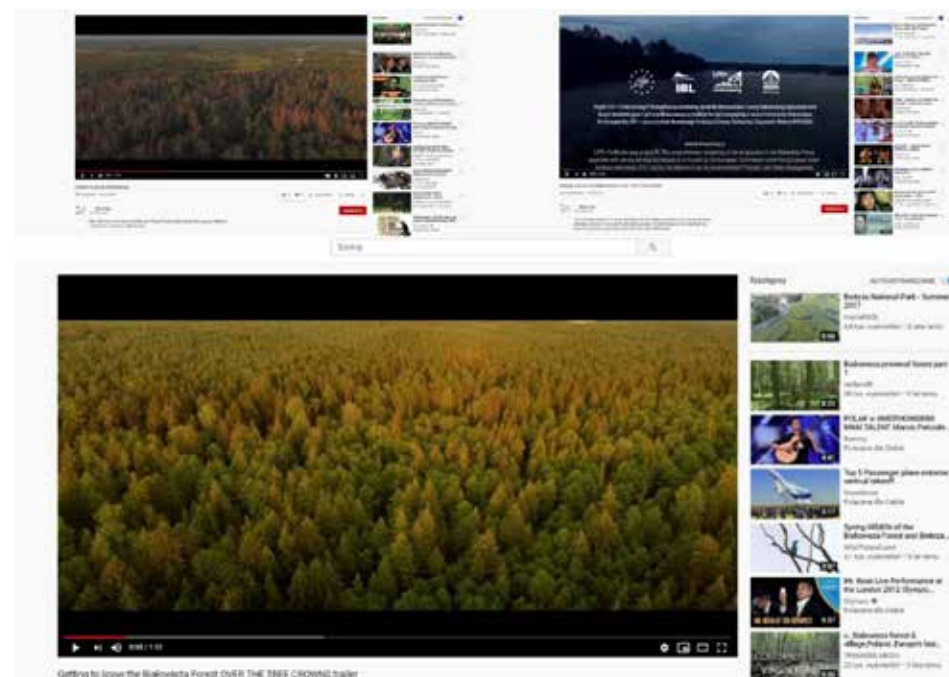

Figure 17.14. ForBioSensing productions on the YouTube platform. Source. FBS

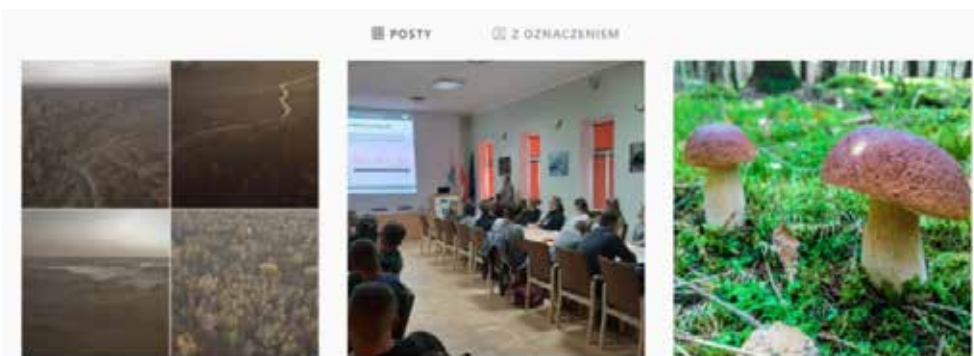

Figure 17.13. Update from Instagram account. Source. FBS

Twitter and Instagram. Substantive texts and extensive photo reports of the work of the project also won audiences on the platforms: Twitter and Instagram. Posts (Fig.17.12, Fig.17.13) on both platforms reached nearly 450,000 people.

YouTube: The productions created in the project (films, spots, reports from meetings) are widely promoted on the internet thanks to the YouTube platform. Films available on the ForBioSensing project channel: https://www.youtube.com/channel/UC9aRcGf_wZs8Gpn-Pg0Cikmg/videos, reached more than 16,590 viewers.

Through the use of indirect communication tools in the ForBioSensing project, it was possible to produce many tangible promotional products that were appreciated and popular with the public. Unfortunately, the outbreak of the SARS-CoV-2 virus in 2020, prevented the continuation of many of them, such as the distribution of leaflets and promotional gadgets due to the cancellation of mass events.

Despite the practical difficulties that arose towards the end of the project, including the outbreak of the Sars-Cov-2 virus and the introduction of a state of emergency in the project area, it can be concluded that the activities using the indirect communication tools described (in simple terms we consider them to be mass communication tools) were a measurable success. The planned, active and continuous use of the above-described indirect communication tools meant that over the course of 6 years, information about the project reached a documented number of almost **5 million recipients** (4,763,796 recipients - as of December 2021). The indicator of documented reach exceeded several times the already ambitious plans that the Beneficiary had set at the beginning of the project.

Mass Communication in the ForBioSensing Project (summary)

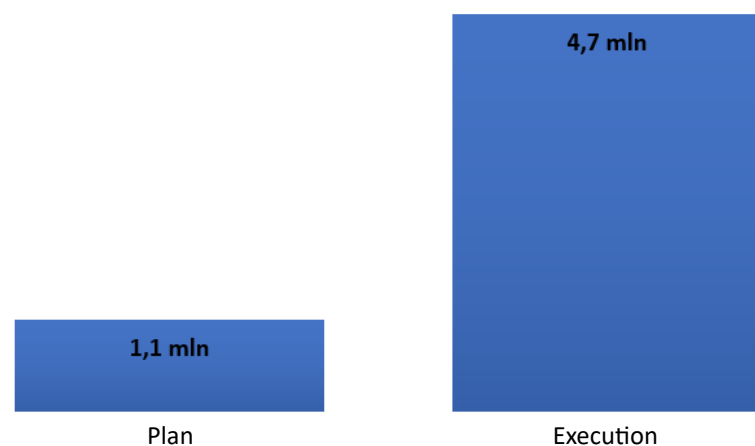

Figure 17.15. Mass communication in the ForBioSensing project (plan + execution). Compiled by FBS

The second group of tools whose active use was planned and realized in the dissemination of the activities of the project was **Direct Communication**. This is a valuable, very labour-intensive but effective method of communication. Organisation of meetings or participation in events organised by other institutions, conducting lectures, trainings, seminars, direct talks with recipients, participation in exhibitions, conferences, open days, meetings with local communities, all made it possible to promote the project more widely and probably more effectively (information was remembered better and longer) than through indirect communication. With this form of communication in the project, the following promotional indicators were achieved:

1. Face-to-face meetings. Readings, lectures and meetings for institutions, universities and local communities constituted an important element of promotion within the project. The aim of this task was to organise meetings and participate in seminars and conferences during which the results of the work being carried out in the project were presented and discussed. 134 meetings were attended during the project, including specialist (74 meetings) and popular (60 meetings). Nearly 15,000 participants took part in all events. Meetings with audiences were planned for different target groups. In practice, for each group, more meetings were held (at the time of writing) than planned. The names of recipient groups are part of the original division adopted in the project documentation.

Table 17.1. Performance indicators of face-to-face meetings by audience. Compiled by FBS

Group	Plan	Execution
General public/Local-Regional/<25	10	19
General public/Local-Regional/25-75	10	12
General public/National/<25	3	2
General public/National/25-75	3	11
General public/National/75-100	3	5
General public/National/>100	2	16
General public/EU-International/<25	2	3
General public/EU-International/25-75	2	1
Specialised audience/Local-Regional/<25	2	11
Specialised audience/National/<25	2	13
Very specialised audience/Local-Regional/<25	2	6
Very specialised audience/Local-Regional/25-75	2	8
Very specialised audience/National/<25	3	3
Very specialised audience/National/25-75	3	2
Very specialised audience/National/75-100	1	1
Very specialised audience/National/>100	1	3
Very specialised audience/EU-International/<25	3	5
Very specialised audience/EU-International/25-75	2	5
Very specialised audience/EU-International/75-100	2	4
Very specialised audience/EU-International/>100	2	10

Information about planned meetings and seminars as well as reports of meetings and seminars held are presented on the project website. Participation in the meetings organised within the scope of the project was free of charge, and participants also received promotional materials. Due to the SARS-CoV-2 virus outbreak in 2020 and the imposition of a state of emergency in the project area, which prevented the continuation of meetings, promotional activities were suspended in this aspect. The prolonged state of epidemic crisis did not permit the planned activities to be completed. The meetings that were made before the epidemic have their own added value. Collaboration with stakeholders has allowed the results obtained in the project to be translated into teaching materials. This made it possible to provide support for the development of young recruits and at the same time helped to promote the project. Among the conferences and meetings in which the ForBioSensing team has participated, it is worth mentioning: conferences under the auspices of the International Union of Forest Research Organisations (IUFRO), the International Society for Photogrammetry and Remote Sensing (ISPRS), conferences organised by the State Forests, the Forest Education Centre in

Rogów, the Polish Society for Photogrammetry and Remote Sensing and the Remote Sensing Club of the Polish Geographical Society and many others.

2. Two-way communication with project stakeholders. Two-way communication in the project was carried out with a number of national bodies and institutions, among them were:
 - National Administration Departments: Ministry of Environment (Departments: Forestry and Preservation of Nature), General Directorate of Environmental Protection and its subordinate Regional Directorates of Environmental Protection (including Regional Directorate of Environmental Protection in Białystok);
 - Local administration departments, including Municipalities: Białowieża, Hajnówka, Narewka, Dubicze Cerkiewne, Czyże and municipalities located in the vicinity of the Białowieża Forest district, Hajnówka District Office, Department of Infrastructure and Environmental Protection of the Marshal's Office of Podlaskie Voivodeship;
 - Companies conducting inventories of Poland's forest resources for the purposes of forest management and nature protection (including forest management plans and protection plans), e.g.: Bureau for Forest Management and Geodesy (including BULiGL Branch in Białystok), Taxus SI Sp. z o.o., Krameko Sp. z o.o.;
 - NGOs, such as WWF, Pracownia na Rzecz Wszystkich Istot, SANTA- Białowieża Forest Protection Association.

Due to the importance of the site covered by the project (Białowieża Forest) the beneficiaries of the project are also the international community, in particular:

- EU institutions: directorates;
- European Forest Platform;
- Confederation of European Forest Owners (CEPF);
- State Forest Association (EUSTAFOR);
- International Union of Forest Research Organisations (IUFRO);
- International Society for Photogrammetry and Remote Sensing (ISPRS);
- European Forest Institute (EFI);
- European Commission and European Parliament;
- LULCaFT (Land Use/Land Cover and Forest Types) regarding issues and the determination and analysis of changes in ABG (Above Ground Biomass) by aerial and satellite remote sensing methods;
- REDD (Reducing Emissions from Deforestation and Forest Degradation), in projects that use remote sensing methods in extensive forest areas.

As in the case of indirect communication, the use of direct communication tools, in particular the active search for events where the ForBioSensing project could be presented, led to the planned indicators for the realisation of the activities being exceeded. The tremendous work of the entire ForBioSensing Team led to face-to-face meetings with over 15,000 members of the public.

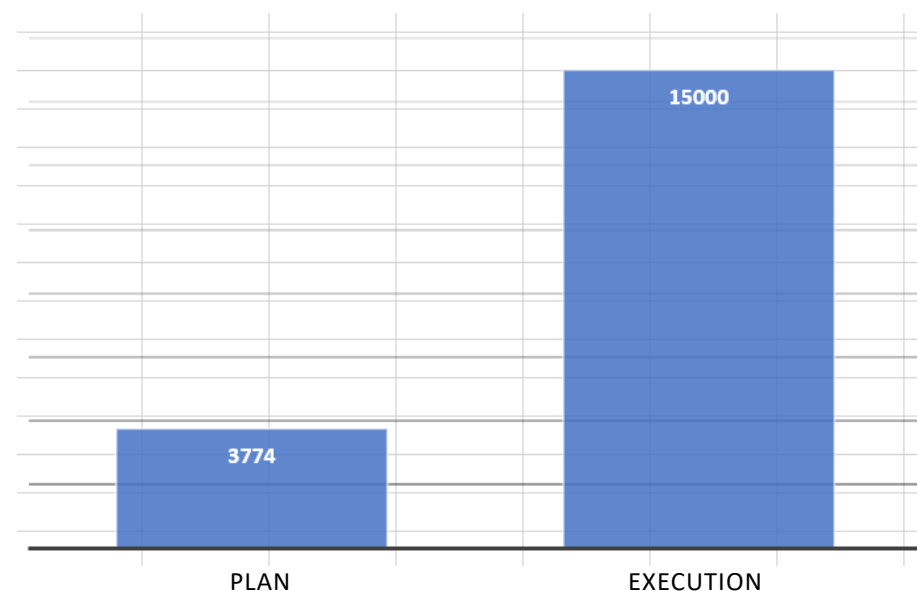

Figure 17.16. Summary of the communication activities of the project. Compiled by FBS, as of October 2021

A wide range of activities and promotional techniques (factuality of messages, appropriate selection of information for target groups, selection of promotional products, reports accompanied by interesting graphic and photographic material) and, above all, the conscientious work of the project team (the basis of the promotional material), made it possible to achieve much higher values for the promotional indicators than originally planned. The multiplex nature of the message ensured that they complemented each other, thus reinforcing the message. The substantive, well-planned and creative work resulted in an effective and memorable promotional campaign for the project. We are pleased and satisfied that this has been achieved.

Thank you for your support!

18. Replication of project results, networking of beneficiaries and dissemination of the LIFE + Programme

Damian Korzybski¹, Wirginia Duranowska², Krzysztof Stereńczak¹

¹ Forest Research Institute, Department of Geomatics, Sękocin Stary, 3 Braci Leśnej St., 05-090 Raszyn

² Forest Research Institute, Scientific Information and Promotion, Sękocin Stary, 3 Braci Leśnej St., 05-090 Raszyn

{d.korzybski, w.duranowska, k.stereńczak}@ibles.waw.pl

Abstract

This publication summarizes the management actions carried out during the major project co-financed by the LIFE programme. This summary focuses in particular on actions for making it possible to re-use the project products, share experiences and knowledge acquired during the implementation of the project and promote the Life programme as part of its dissemination. The history of the LIFE programme and the project's controlled communication activities were also characterised. This chapter describes how the project's data has been shared in a way that ensured the practical implementation of the project's results in almost 80 applications worldwide.

Keywords: re-use, networking, data sharing, open access, replication of project products

The ForBioSensing project, the subject of this publication, is one of the many undertakings being conducted in European Union, co-financed from the LIFE programme. This chapter presents the experiences of the project team in terms of the functioning of the project within the LIFE programme, in the transfer of effects outside the project, the cooperation with other beneficiaries (so-called networking), and the dissemination of the LIFE programme as part of promotion activities. The article also briefly characterizes the history of the LIFE programme and the requirements of the 2013 call for proposals, under which the proposal for the ForBioSensing project was submitted.

The LIFE programme has funded nature projects in the European Union area for over 35 years. The basis for the establishment of the LIFE instrument was the adoption of the Single European Act in 1986. This act, together with the Fifth Environmental Action Programme (1993), contributed to the reform of the European nature conservation system, and the LIFE programme became the only European Union's financial mechanism dedicated exclusively to

environmental protection. Over successive editions, the structure of the programme has been modified to best meet the objectives set for the states of the European Union in environmental protection, including, since 2014, a separate sub-programme for climate change mitigation. Every few years, the main objective and specific objectives of the LIFE programme are updated as new challenges arise in the Community. A new budget and the rules for co-financing projects are established. So far, six phases of the programme have been announced, namely: "LIFE I Programme" (1992–1995), "LIFE II Programme" (1996–1999), LIFE III Programme (1999–2006), LIFE+ Financial Instrument (2007–2013), "LIFE Environment and Climate Action Programme" (2014–2020) and "LIFE" (2022–2027) under which a call for projects is currently open.

The LIFE programme is managed by the European Commission which issues a call for proposals (invitation to submit applications) once a year. Any entity (public or private units and institutions) registered in the territory of an EU Member State can be a beneficiary of the LIFE programme. The standard co-financing of a LIFE project by the European Commission is up to 55% of the value of eligible costs and up to 60% for nature projects (for projects serving priority species and habitats, the co-financing can be up to 75%). Polish applicants may also apply for co-financing of the project from the National Fund for Environmental Protection and Water Management, which supplements the financial engineering of the project up to 95% of the eligible costs.

The LIFE programme is a European Union's financial instrument that has co-financed and supported thousands of EU projects in the field of environment and climate over its many years of operation. It has backed financially many teams from around the world. The projects co-funded under this programme have carried out a number of studies addressing the issues of climate, threatened species of plants and animals, and natural sites management. For more information on the LIFE programme, refer to its official website: <https://ec.europa.eu/life>.

The scientists from the Forest Research Institute seized the opportunity to obtain co-financing for conservation-related activities under the LIFE Programme in 2013. At that time, a team of employees from the then Department of Computer Science and Modelling (now Department of Geomatics) and the Department of Natural Forests, applied for the funding of the ForBioSensing project. The application for the funding was submitted within the „LIFE+” Programme's 2007–2013 edition of the „Environmental Policy and Management” component. The submitted application was given high and positive scores by the European Commission, thanks to which it was earmarked for co-financing.

Some of the most important tasks of each project co-funded from the LIFE Programme, in addition to the strictly substantive project objectives, are activities aimed to:

- reuse the developed project products and/or develop project results in such a way that they can be used under similar conditions but in a different location within the Community, a property called “transferability and replicability of project results”,
- sharing of experience and knowledge gained during project implementation with other project beneficiaries through networking,

- promoting the Life Programme as widely as possible through dissemination of project information.

Each of the above-mentioned areas of project activities has been included in the ForBioSensing project task plan.

As already mentioned, one of the most important tasks of any project co-financed by the LIFE Programme is the transfer and replication of project results. One of the most important products of the ForBioSensing project is a database of source data describing nearly one hundred characteristics of trees or stands and other elements of forest environment from the entire area of the Polish part of the Białowieża Forest. These continuous data, collected during the monitoring between 2015 and 2021, on the entire area of the BF or on nearly 1000 different types of monitoring plots, come both from traditional measurements in the field, and from the state-of-the-art remote sensing techniques. Data collected during the ForBioSensing project, obtained by scientific measurement methods, constitute a unique, uniform, mutually comparable and objective dataset (database) that can be used for management of the invaluable natural site, the Białowieża Forest. Already at the initial stage of works, the Project Managers have been aware of the great value and high potential of the repeated use of the planned source data set on the forest environment of the Białowieża Forest in activities other than project activities. Therefore, they decided to make the data available to all stakeholders already during the project, with no practical restrictions and the same rules for all. The data sharing model in the ForBioSensing project, which met most of the requirements for data repositories created as open access resources, ensured the effective implementation of the commitment to share and replicate the project results on a scale never seen before in the Forestry Research Institute. As early as during the implementation of the project, project data were transferred to other institutions or individuals almost 80 times over 6 years under licensing agreements. The data generated by the project was not only used in the country, but also in Europe and worldwide. The transferred data have been used in the practical management of Białowieża Forest by the institutions qualified for this purpose (forest districts, regional directorates of State Forests, the Ministry and Białowieża National Park). With the shared databases, scientific institutions conduct research and educational activities and develop the scientific background of many people (numerous master's theses, doctoral dissertations and post-doctoral theses have been written based on the data). The project's data is used by non-governmental organizations to monitor the state of nature, underlies the publishing of popular science journals, and is part of a global network for the exchange of data that forms the basis for assessing the global natural environment status. Each of the licences (the legal basis on which the data was provided to the licensees) had a clearly specified purpose of the transferred resources. Therefore, it can be concluded that the project data ensured that the project results were reused or replicated in nearly 80 applications even before the project completion and official publications of results. It can be assumed that after the publication of this monograph and the project results, the number of practical implementations will increase. For a complete list of licences, and the purposes of sharing project data, the scope of the data shared, and the licensees, see the project website at www.forbiosensing.pl

Another of the described essential tasks that apply to all the projects co-financed by the LIFE programme, is networking. Simply put, this is a mandatory, permanent project activity aimed at sharing project experiences and knowledge with the other beneficiaries of the LIFE programme. This activity ensures not only a systematic exchange of knowledge but also mutual assistance and support between the ongoing projects. It is an opportunity to acquire additional skills, develop project competencies, carry out tasks with a scope broader than one project and provide synergism and interoperability in the performance of various projects tasks. Networking activities were actively conducted as part of the ForBioSensing project, primarily using the following tools:

- meetings with other projects during a series called “LIFE Platform Meeting”,
- participation in LIFE Information Days.

The series of meetings of Polish LIFE projects called “LIFE Platform Meeting” is a grass-roots initiative of one of the beneficiaries of 2015. During the series, all interested beneficiaries and representatives of the project co-funding institutions, i.e. project supervisors from the European Commission and the National Fund for Environmental Protection and Water Management, participated in an annual 2-3 day away meeting in the area of implementation of a project. The meetings were held under a fixed routine. Most often, on the first day, the platform meeting participants agreed on the issues to be discussed, and then, the thematic sub-groups discussed key experiences, successes and problems. During discussions at the so-called “thematic tables”, the groups talked about the financial settlement of the LIFE projects, reporting to supervisory institutions, accounting issues, sustainability of the project (After LIFE), problems with land purchase, interpretation of legal regulations, effective communication with stakeholders, good practices in the dissemination of project results, principles of data sharing, solving substantive problems and more. A given thematic table was usually led by a project representative with the greatest experience in a given area. All-day discussions usually ended with a summary of findings and even quite often with the drawing up a group stance: a common line of interpretation for issues or regulations on Polish LIFE projects. During the next day's meeting, the host, a project's Beneficiary, presented his achievements and had them assessed by other participants. Representatives of the ForBioSensing team got fully involved in the discussion every year, between 2015 and 2019, often leading thematic tables, sharing with the participants the experience gained during the project and also learning from others. It was a good opportunity to meet other LIFE project beneficiaries and address many project issues.

Unfortunately, the outbreak of the Sars-Cov-2 virus in 2020 prevented the meetings from continuing, and the persistent epidemic did not allow them to resume until this publication was issued. According to the management of the ForBioSensing project, this grass-roots series of meetings of all institutions that have implemented supervised the Polish LIFE projects was the most effective way of networking and should be resumed as soon as possible.

Sharing of project experiences within networking was possible on the annual „LIFE Information Day” organized annually by the National Fund for Environmental Protection and Water Management. The aim of the meeting is to open the annual call for proposals for



Figure 18.1. The meeting at a “thematic table” in a Platform Meeting in Janów Lubelski, 2019 (photo FBS)

the LIFE programme at the national level, and to present the funding opportunities offered by the programme and the general rules for applying for funds under the current call. The LIFE information day will be attended by representatives of the Executive Agency of the European Commission (formerly Executive Agency for Small and Medium-sized Enterprises, EASME), the Ministry of Climate and Environment, the NFEPWM and beneficiaries of the LIFE programme. Apart from project booth teams and members of the National LIFE Contact Point, representatives of information centres of other European Union and national institutions were present. The ForBioSensing project has participated in these meetings every year between 2015 and 2019, taking advantage of the unique opportunity to learn about the LIFE programme, share experiences with other LIFE beneficiaries, and present the project activities to a wide range of potential applicants. A stand of the ForBioSensing Project Office, presenting the latest developments and equipment for observing the natural environment of the forest, both from the ground and from aircraft or a satellite, as well as unusual promotional campaigns were very popular every year. It was also important to have the unofficial talks with other Beneficiaries and representatives of institutions supervising the project and to make new contacts.

Unfortunately, this form of networking was effectively suspended by the Sars-Cov-2 epidemic, as were the Platform Meetings, changing the format of Life Information Days from direct to remote and limiting them to the presentation of co-financing opportunities to new applicants.



Figure 18.2. The Białowieża cinnamon rolls - a treat offered at the ForBioSensing stand at the LIFE Information Days (photo FBS)

Since its operational beginning, the project team has had the pleasure of carrying out many activities related to the monitoring of the condition of Białowieża Forest stands and promoting project activities under the LIFE+ financial instrument. The promotion of the LIFE Programme is the responsibility of the individual Beneficiaries. The ForBioSensing project team has fulfilled this responsibility with conviction and pleasure. On several occasions, readers were able to learn about ForBioSensing’s activities related to the LIFE+ programme on social media and the project website. The activities included: LIFE+ Anniversary Celebrations, Information Days and many meetings held with Project stakeholders. Through personal communication, Project representatives participated in 134 specialist and popular meetings. This allowed the project itself and the LIFE Programme to be presented to an audience of over 15,000 people. The logo of the LIFE Programme was constantly displayed as ForBioSensing tasks were carried out. It was seen on measuring devices, documents, and promotional gadgets. At each of the meetings, the ForBioSensing activities were promoted and the importance of the LIFE+ funding instrument was highlighted.

A special opportunity to promote the LIFE Programme came in 2017, during the celebrations of the 25th anniversary of this form of funding of nature projects. On this occasion, the ForBioSensing project provided information about the anniversary and presented the programme itself, including some unusual forms of promotion. As in the popular saying „the way to a man's heart is through his stomach”, the project staff provided refreshments, namely



Figure 18.3. Lesson in primary school in Młochów

sweet cinnamon buns from Białowieża with the birthday logo of the 25th anniversary of the LIFE Programme and served them to the guests of the LIFE Information Day 2017 and the participants of the Earth Day at the Mokotowskie Fields in Warsaw. During the event, a giant postcard was created on which hundreds of people had written their wishes for the Programme organisers. This postcard was sent to the European Commission.

Since the beginning of the ForBioSensing project, the project management has considered both content-specific activities and the dissemination of the results, enabling replication of the results and networking as very important. The dissemination was planned and well addressed (planned, dedicated role in the project team), resulting in much higher promotional indicators than planned. How the project dissemination was planned and carried out is described in detail in a separate chapter of this publication. The ways in which replication of project results, data sharing, networking and the dissemination of the LIFE Programme were ensured are some of the elements of knowledge and experience sharing in the ForBioSensing project and can inspire the launch of new projects. The performance indicators for the dissemination of project results exceed the planned values many times over, and a large number of licenses related to the provision of data for practical use, are proof of the effectiveness of the activities in the above mentioned areas of the project.

19. Project summary

Krzysztof Stereńczak, Damian Korzybski

Forest Research Institute, Department of Geomatics, Sękocin Stary, 3 Braci Leśnej St., 05-090 Raszyn
{k.sterenczak, d.korzybski}@ibles.waw.pl

This publication is the result of a project that presented a great scientific and organisational challenge. It is the result of the work of a large team of people. At this point we, as the project management, would like to thank all these people for their dedication, diligence in the work done and their mutual support. We thank Marta Piwowarska for supporting the management in monitoring the project progress indicators. We thank Ewa Zin for her commitment and support in dendrometric work. We thank Rafał Paluch for coordinating the team from the Department of Natural Forests in Białowieża. We thank Agnieszka Kamińska for her support in various statistical analyses, which enabled many scientific works within the project. We thank Łukasz Kuberski for coordinating the fieldwork and many additional initiatives. We thank Miłosz Mielcarek, who participated in a variety of different tasks related to spatial analyses. We thank Bartek Kraszewski and Rafał Sadkowski for automating many analytical processes that enabled comprehensive spatial data analysis. We thank Małgorzata Białczak for the analysis and processing of many remote sensing data. We thank Maciej Lisiewicz for his dedication and constant willingness to take on various tasks. We thank Żaneta Piasecka for her assistance in many complex spatial analyses, often solving problems new to her. We thank Aneta Modzelewska for processing hyperspectral data, Kamil Pilch and Agnieszka Bosak for his hard work in the field and in the dendrochronology laboratory. We thank Adam Szulc for his positive energy and phytosociological work. Karol Rzczycki for his hard work in the field and conscientiousness in survey work. We thank Dorota Rokosz, Magdalena Maciejewska and Żaneta Młodzianko for their meticulousness and accuracy in performing very responsible tasks related to the financial management of the project. We thank Virginia Duranowska and Olga Jasińska for the excellent promotion of the project and dissemination of its results. We thank Tomek Zygmunt for his participation in the scripts of the films made within the ForBioSensing project. We thank Krzysztof Szyłak and Paweł Sańczyk for their assistance in meteorological analysis. We thank Renata Wilkowska for her photogrammetric analyses. We thank Kamil Kędra for his insight and meticulousness. We thank Maja Sadkowska, Dorota Raczkowska-Paluch, Ania Markiewicz, Sylwia Kurpiewska, Maciej Kobielski, Monika Gutman, Anna Adamczyk, Tomasz Strakacz, and Ewa Kłopocka for their administrative, personnel, and organisational work for the project, including execution of many procurement contracts. We also thank Radek Bałazy, Adrian Wasiluk, Agata Sałachewicz, Sławomir Mioduszewski, Michał Androsiuk, Krzysztof Gaszewski, Grzegorz Ledworuch, Bartosz Piekło, Jakub Słowik, Anna Białomyzy, Janusz Pawłowski, Ariel Cybula, Krzysztof Socha, Bartłomiej Kusał, Paweł Nowak, Ewa Siedlarczyk, Benedykt Górecki, Marek Raniszewski, Piotr Kwiatkowski, Rafał Bartosz, Michał Jedliński, Sebastian Bury, Hubert Jakoniuk, Monika Dudko, Paula Całusińska,

Karolina Parkitna, Kazimierz Borowski, Janusz Czerepko, Dorota Dobrowolska, Wojciech Gil, Andrzej Boczoń for their contribution and involvement in the implementation of the project tasks.

Our special thanks go to the people who supported the project with various voluntary actions. During the seven years of the project, there were several dozens of people who devoted their free time to the project, from a few hours to several months. As a rule, these were people who were at the beginning of their careers and brought a lot of positive energy and commitment. Their commitment, creativity and dedication can be a role model to follow.

The ForBioSensing project had many goals. One of them was to widely publicise the activities carried out under the project. A major success was that the project's data and results were used nearly 80 times in practise and science. Such a large number of implementations of the project results would not have been possible without the support of the Steering Committee. The composition of the Steering Committee was broad and consisted of:

- Director of the Forest Research Institute
- Deputy Director General of the State Forest National Forests Holding
- Director of the Forestry and Hunting Department of the Ministry for Climate and Environment
- Deputy Director of the Bureau for Forest Management and Geodesy, Branch in Białystok
- Head of the Department of Forest Silviculture, Faculty of Forestry, Warsaw University of Life Sciences
- Head of the Department of Forest Management Planning and Forest Economics, Faculty of Forestry, Warsaw University of Life Sciences
- Director of the Mammal Research Institute, Polish Academy of Sciences, Białowieża
- Director of the Regional Directorate of State Forests in Białystok
- Director of the Regional Directorate for Environmental Protection in Białystok
- Director of the Białowieża National Park
- Head of the Białowieża Forest District
- Head of the Hajnówka Forest District
- Head of the Browsk Forest District
- Governor of Hajnówka district
- Mayor of the Commune of Białowieża
- President of the Polish Forest Association, Branch in Białystok
- Director of the "Białowieża Forest" National Park

- President of the Polish Society for Bird Protection
- President of the Board of the League for Protection of Nature
- Member of the association SANTA Defence of the Białowieża Forest
- Dean of the Faculty of Civil Engineering and Environmental Sciences, Białystok University of Technology
- Program Director, Greenpeace Poland Foundation
- Director of the Coordination Centre for Environmental Projects
- Head of the LIFE Department of the National Fund for Environmental Protection and Water Management.

At this point, we would like to thank the Steering Committee for their support in implementing the project tasks and informing us of the current needs, which enabled the delivery of products that are used by many project participants in their daily work.

In addition to project activities, there has been a flurry of publication activity aimed at developing methods for monitoring forest complexes using remote sensing data. As a result of the high activity of the project team, as well as the established collaboration with various scientists, the project published dozens of scientific papers in the best journals (27 scientific papers in journals such as: Nature, Nature Communications, Proceedings of the National Academy of Sciences, Remote Sensing of Environment, Forest Ecology and Management, Remote Sensing, Forestry: An International Journal of Forest Research, International Journal of Applied Earth Observation and Geoinformation, Scientific Data, International Journal of Remote Sensing and Forests). At this point, we would especially like to thank Stanisław Miścicki, Yousef Erfanifard, Marco Heurich, Fabian Fassnacht, Gaia Vaglio Laurin, Alex Olpenda, Mats Niklasson, Hooman Latifi, Laura Duncanson, Tomasz Oszako, Justyna Nowakowska, Niklaus E. Zimmermann, and Dmitri Schepaschenko.

Our special thanks go to the project coordinators/tutors at the co-funding institutions. Throughout the project, there has been constant, intensive and exceptionally constructive cooperation with the project supervisor at the European Commission, Mr. Zbigniew Karaczun. Thank you for your understanding and openness to our suggestions in connection with the ongoing response to various questions that arose during the project. Thank you for being an „ambassador” of our matters during contacts with the European Commission. From the recipient's perspective, this has undoubtedly been exemplary cooperation. An equally constructive and effective cooperation continued with the guardians of the project in the National Fund for Environmental Protection and Water Management, namely: Marta Wronka, Radosław Domagała, Małgorzata Tomaszewska, Andrzej Muter and Leszek Jóskowiak. We would like to thank these people for their support in solving issues, trust and at the same time joint control over the correct use of public funds and the course of the project. Thank you for sharing your valuable experience from other projects with us. Despite the fact that the above coordinators were mainly in charge of supervising the beneficiary to carry out the project correctly, the project management had full confidence that they could count on their help in any

situation. Together with the Steering Committee, you were undoubtedly an important part of the ForBioSensing project management team.

Managing the complex ForBioSensing project, including working with the above-mentioned large team of stakeholders, numerous institutions and interlocutors, is a challenging and responsible, but also rewarding task. Project management roles and persons: Project Manager - Krzysztof Stereńczak, Deputy Project Manager, Administrative Manager - Damian Korzybski would like to express their sincere gratitude to each other for the long and seemingly fruitful cooperation in managing the ForBioSensing project. Willingness to manage the project in the best possible way, especially respect for the people working on it, countless joint meetings, discussions, disagreements, common solutions to difficult project issues, striving for mutual understanding, shared responsibility, synergy of various skills and experience and different personality traits have enabled the management to lead the ForBioSensing project to its upcoming positive conclusion.

We are convinced that the experience and knowledge gained in the ForBioSensing project will bear fruit in many ambitious undertakings in the future. Once again, the project management would like to thank all participants for their efforts and dedication. It has been an honour and a pleasure to work hard together.

The ForBioSensing project will end in April 2022, but the image of the Polish part of the Białowieża Forest will be preserved and archived in the data, information and knowledge gained and created by the project. We hope that future users will appreciate the quality and dedication of the entire ForBioSensing team and that the results of the project will contribute to further understanding of the processes taking place in the Polish part of the Białowieża Forest now and in the future.

20. Attachments

1. Map of monitoring plots

As a part of the project, 685 monitoring plots (including 355 located in a uniform grid of 1300 m squares), 320 gap test plots and 15 spruce plots were established in Białowieża Forest. They form the basis for multi-year, comprehensive monitoring of the dynamics of the forest stands. More than a dozen different biometric characteristics of the trees were measured (including height and diameter at 1.3 m from the ground). Forest regeneration, i.e. the emergence of the new generation of trees, was also inventoried and analysed. The established monitoring plots represent the entire variability in the habitat and stand conditions of Białowieża Forest. Measurements were taken three times, i.e. in 2015, 2017 and 2019. The aim of the field work was to determine the condition of the forest stands and to collect comparative (reference) materials for data acquired using remote sensing methods.

2. Map of threat posed by dead trees standing along communication routes

The map shows the threat posed by standing dead trees located near transport routes. The map was produced based on remote sensing data acquired in 2019 (airborne laser scanning data and high-resolution aerial imagery) and GIS data in the form of a vector layer depicting the road network in the Białowieża Forest (with a total length of over 1000 km). On the basis of available data, a methodology was developed for classifying the risk caused by dead trees standing in the immediate vicinity of traffic routes. Red indicates high risk (category 1), yellow indicates medium risk (category 2) and green indicates no risk from standing dead trees (category 3). The developed method can provide valuable support in decision-making process for administrative units of forest complexes, where mass tree dieback occurs. Details of the methodology are described by Stereńczak et al. (2017).

3. Tree species composition map

One of the basic and crucial information about a forest stand is its species composition. The use of airborne hyperspectral data makes it possible to obtain spatially continuous information on tree species in the area of investigation. The high informativeness of these data and the application of machine learning algorithms for classification made it possible to develop a map of the dominant tree species in Białowieża Forest. Seven classes were distinguished, including the most common species (pine, spruce, oak, hornbeam, alder, lime and birch) and the class "other". The map presented here is based on hyperspectral imaging acquired in 2019. Details of the methodology are described by Modzelewska et al. (2020).

4. Dynamics of tree dieback

The dieback of spruce (*Picea abies* (L.) H. Karst), which is caused, among other things, by bark beetle (*Ips typographus*) gradation, is a dynamic process and cause significant changes in forest stands. The integration of multiple remote sensing data sets gives the opportunity for non-invasive observations of this phenomenon in a broader perspective - for the entire area of Białowieża Forest. Maps of the occurrence of dead spruce trees in 2015–2019, were compiled using multi-temporal remote sensing data: airborne laser scanning, airborne hyperspectral imaging, as well as satellite and airborne multispectral imaging. Classification was performed on the basis of values from individual spectral channels and vegetation indices. The classification results were integrated with segments representing the crowns of individual trees, which were generated from the Crown Height Model. The changes that occurred in each year of the project were analysed, and the map presented here illustrates the increase in the number of dead trees in the forest subcompartments between 2015 and 2019.

5. Map of deadwood volume in Białowieża Forest

The positive role of deadwood in nature is unquestionable. Deadwood fulfils many important functions in forest ecosystems, including being an important part of the nutrient cycle, providing a habitat for many species of fungi, plants and animals, and protecting the soil. Field measurements carried out on monitoring plots also provided data on the amount of deadwood. The conducted measurements recorded locally high volume of deadwood. In 2019, approximately 60% of the sample plots had dead wood volume values above 100 m³ ha⁻¹. This map shows the amount of dead wood in the sample plots recorded in the 2019.

6. Map of forest health status

One of the most important information about a forest stand is its health status. The use of aerial hyperspectral data allows, the calculation of Normalised Difference Vegetation Index (NDVI) and Normalised Difference Water Index (NDWI). The resulting map presents the health status (NDVI index) of Białowieża Forest stands calculated from hyperspectral imaging acquired in 2019.

7. Map of forest communities of Białowieża Forest

This map is the first attempt to delineate the forest communities of the Białowieża Forest on the basis of the latest remote sensing and ground data. The classification of forest communities according to J.M. Matuszkiewicz (2008) was applied, according to which phytosociological relevés derived from the materials of the natural and cultural inventory of Białowieża Forest were identified in terms of actual and potential vegetation. In the process, 12 forest communities with a very diverse representation were recognised, with the lime-oak-hornbeam forest predominating. Available remote materials were used for the analysis, including airborne laser scanning, hyperspectral data, and GIS data in the form of a vector hab-

itat map. The accuracy of the map was verified in the field and estimated to be around 70%. Remote sensing methods had the highest accuracy for alder, riparian and fresh oak-hornbeam forests (more than 85%) and the lowest accuracy for deciduous and mixed deciduous forests. Low accuracy was found in the case of replacement forest communities on mixed pine-oak forest habitats and the collective heterogeneous group of forest replacement communities LZZ-others.

8. Map of growing stock in Białowieża Forest

Remote sensing data provides a wealth of information about forest areas. Airborne laser scanning data was successfully used to obtain quantitative forest data such as number of trees, basal area and tree height. The information obtained can be used to estimate many important characteristics of forest stands, e.g. growing stock. The map presented here shows the volume of living trees in Białowieża Forest estimated on the basis of remote data acquired in 2019.

9. Global solar radiation map

One of the factors critical to the growth and functioning of vegetation in the forest is access to sunlight. Determining the amount of light reaching the forest floor allows us to understand its impact on changes in the stand, such as the formation of a new forest generation, called regeneration. Obtaining information on the amount of solar radiation penetrating beneath the canopy of a stand for a large forest complex is possible through remote sensing. The airborne laser scanning (ALS) data and hemispheric imaging were used to model the amount of solar radiation reaching the forest floor. The developed map is the result of implementing solar radiation models for the entire study area for the year 2019.

Forest Research Institute

Sękokin Stary 2022

Locations of monitoring plots

Appendix to Chapter 4 of the monograph: „Comprehensive monitoring of stand dynamics in Białowieża Forest using remote sensing data” (Published by IBL, Sękocin Stary, 2022)
Elaborated by: L. Kuberski, M. Mielcarek

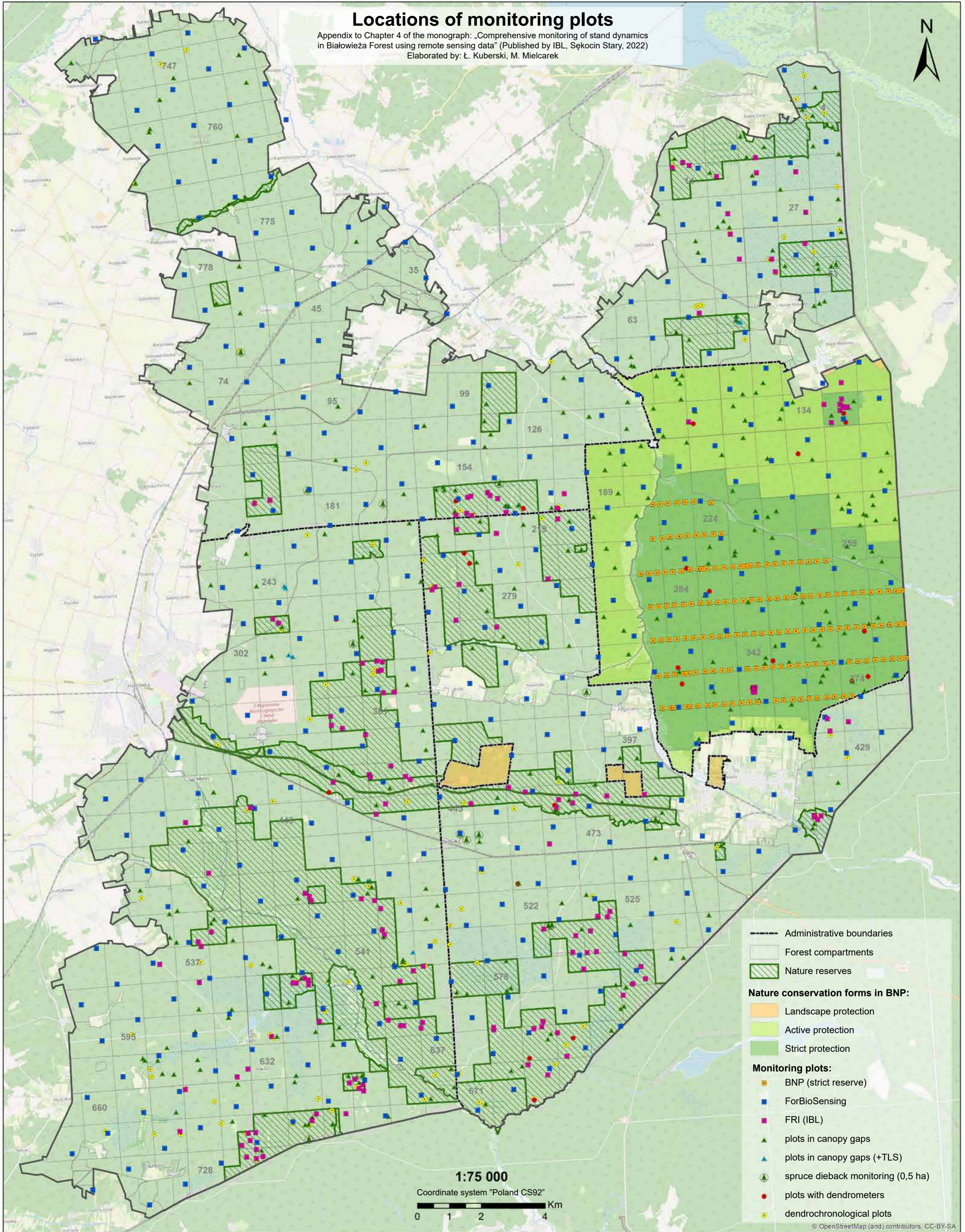

- Administrative boundaries
- Forest compartments
- ▨ Nature reserves
- Nature conservation forms in BNP:**
- ▨ Landscape protection
- ▨ Active protection
- ▨ Strict protection
- Monitoring plots:**
- BNP (strict reserve)
- ForBioSensing
- FRI (IBL)
- ▲ plots in canopy gaps
- ▲ plots in canopy gaps (+TLS)
- ▲ spruce dieback monitoring (0,5 ha)
- plots with dendrometers
- dendrochronological plots

1:75 000

Coordinate system "Poland CS92"

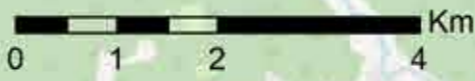

© OpenStreetMap (and) contributors. CC-BY-SA



The map has been created as a part of ForBioSensing LIFE+ project PL "Comprehensive monitoring of stand dynamics in Białowieża Forest supported with remote sensing techniques"



Forest Research Institute
Sękocin Stary, Braci Leśnej 3 St., 05-090 Raszyn
Tel. +48 22 71 50 300; Fax +48 22 72 00 397
e-mail: ibl@ibles.waw.pl; www.ibles.pl
KRS: 0000039417; REGON: 000115832; NIP: 5250009200

ForBioSensing Design Office
Sękocin Stary, Braci Leśnej 3 St., Building B., 230
05-090 Raszyn
Tel. +48 22 71 50 663
e-mail: fbs-biuro@ibles.waw.pl



LIFE+ ForBioSensing PL Comprehensive monitoring of stand dynamics in Białowieża Forest supported with remote sensing techniques co-funded by Life Plus and The National Fund for Environmental Protection and Water Management in Poland, contract number LIFE13 ENV/PL/000048, 485/2014/WN10/OP-NM-LF/D

Threat posed by dead trees standing along communication routes (year 2019)

Elaborated by: M. Mielcarek, B. Kraszewski, Ż. Piasecka, K. Stereńczak, M. Lisiewicz

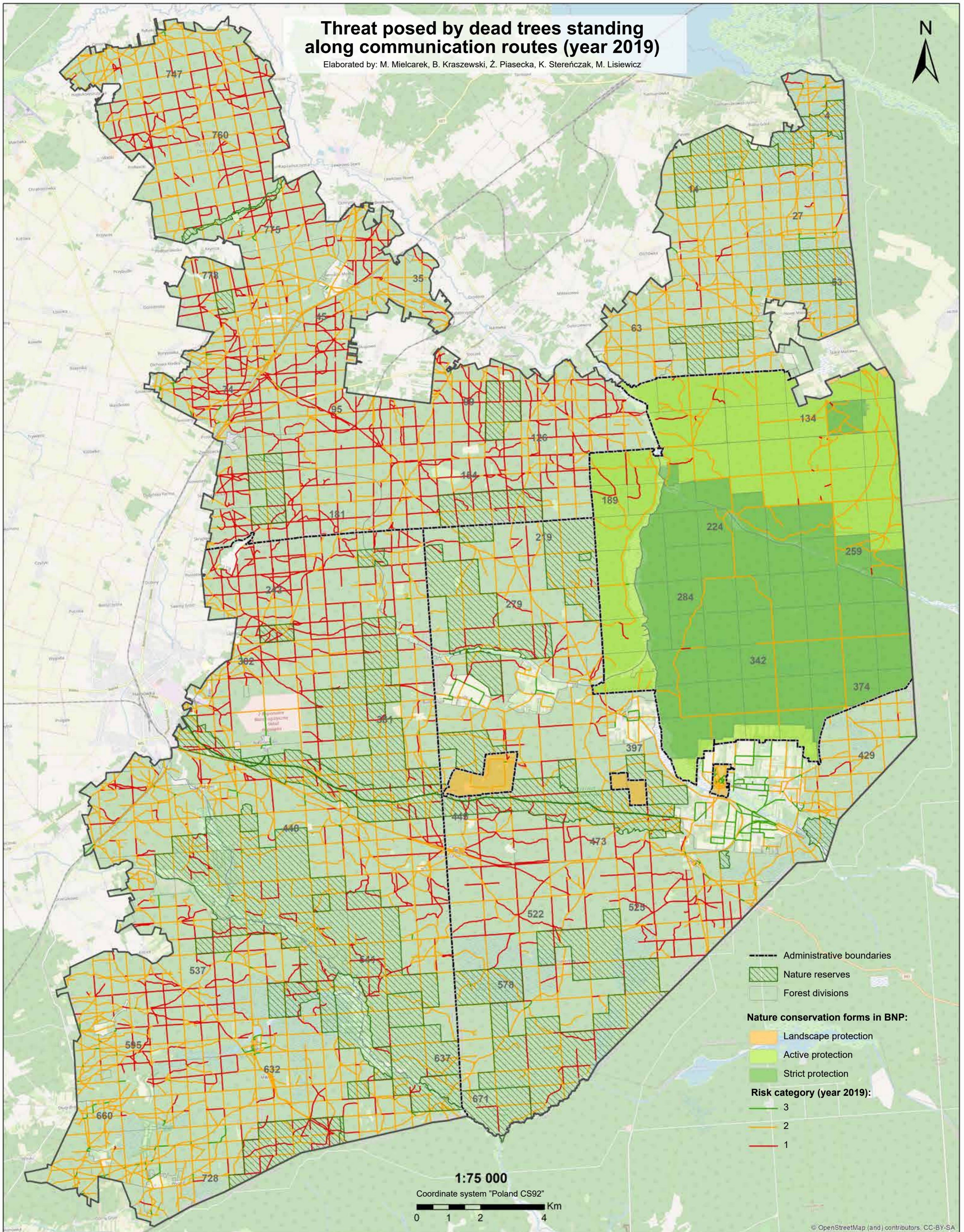

- Administrative boundaries
- ▨ Nature reserves
- ▭ Forest divisions
- Nature conservation forms in BNP:**
- ▭ Landscape protection
- ▭ Active protection
- ▭ Strict protection
- Risk category (year 2019):**
- 3
- 2
- 1

1:75 000

Coordinate system "Poland CS92"

0 1 2 4 Km

© OpenStreetMap (and) contributors. CC-BY-SA



The map has been created as a part of ForBioSensing LIFE+ project PL "Comprehensive monitoring of stand dynamics in Białowieża Forest supported with remote sensing techniques"



Forest Research Institute
 Śękocin Stary, Braci Leśnej 3 St., 05-090 Raszyn
 Tel. +48 22 71 50 300; Fax +48 22 72 00 397
 e-mail: ibl@ibles.waw.pl; www.ibles.pl
 KRS: 0000039417; REGON: 000115832; NIP: 5250009200

ForBioSensing Design Office
 Śękocin Stary, Braci Leśnej 3 St., Building B., 230
 05-090 Raszyn
 Tel. +48 22 71 50 663
 e-mail: fbs-biuro@ibles.waw.pl



LIFE+ ForBioSensing PL Comprehensive monitoring of stand dynamics in Białowieża Forest supported with remote sensing techniques co-funded by Life Plus and The National Fund for Environmental Protection and Water Management in Poland, contract number LIFE13 ENV/PL/000048, 485/2014/WN10/OP-NM-LF/D

Tree species composition (year 2019)

Appendix to Chapter 12 of the monograph: „Comprehensive monitoring of stand dynamics in Białowieża Forest using remote sensing data” (Published by IBL, Sękocin Stary, 2022)
Elaborated by: A. Modzelewska, M. Mielcarek

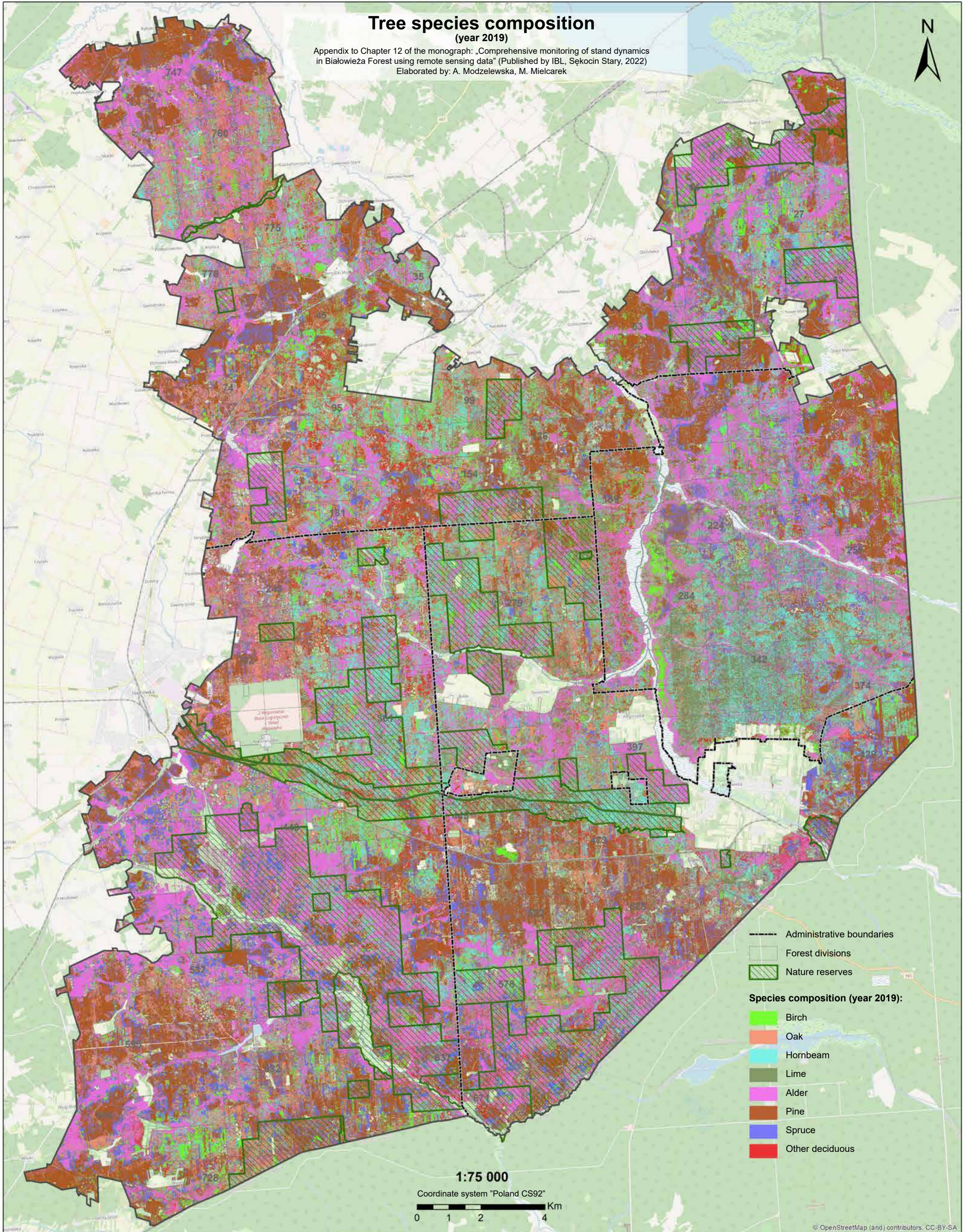

© OpenStreetMap (and) contributors. CC-BY-SA



The map has been created as a part of ForBioSensing LIFE+ project PL "Comprehensive monitoring of stand dynamics in Białowieża Forest supported with remote sensing techniques"



Forest Research Institute
Sękocin Stary, Braci Leśnej 3 St., 05-090 Raszyn
Tel. +48 22 71 50 300; Fax +48 22 72 00 397
e-mail: ibl@ibles.waw.pl; www.ibles.pl
KRS: 0000039417; REGON: 000115832; NIP: 5250009200

ForBioSensing Design Office
Sękocin Stary, Braci Leśnej 3 St., Building B., 230
05-090 Raszyn
Tel. +48 22 71 50 663
e-mail: fbs-biuro@ibles.waw.pl



LIFE+ ForBioSensing PL Comprehensive monitoring of stand dynamics in Białowieża Forest supported with remote sensing techniques co-funded by Life Plus and The National Fund for Environmental Protection and Water Management in Poland, contract number LIFE13 ENV/PL/000048, 485/2014/WN10/OP-NM-LF/D

Dynamics of trees dieback

(2015 - 2019)

Appendix to Chapter 13 of the monograph: „Comprehensive monitoring of stand dynamics in Białowieża Forest using remote sensing data” (Published by IBL, Sękocin Stary, 2022)

Elaborated by: A. Kamińska, M. Lisiewicz, B. Kraszewski, K. Stereńczak, M. Mielcarek

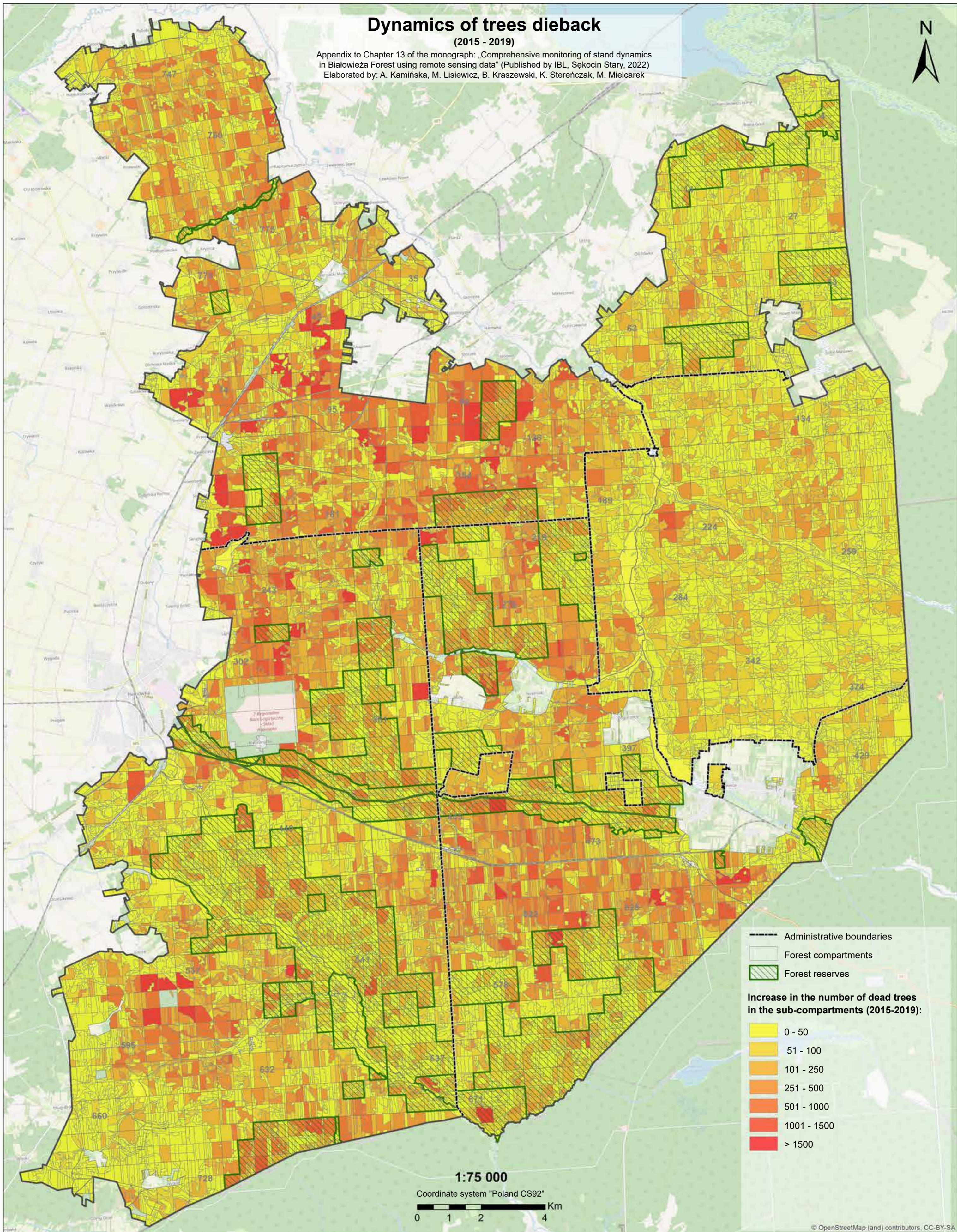

Administrative boundaries
 Forest compartments
 Forest reserves

Increase in the number of dead trees in the sub-compartments (2015-2019):

0 - 50
51 - 100
101 - 250
251 - 500
501 - 1000
1001 - 1500
> 1500

1:75 000

Coordinate system "Poland CS92"

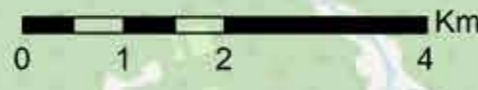

© OpenStreetMap (and) contributors, CC-BY-SA



The map has been created as a part of ForBioSensing LIFE+ project PL "Comprehensive monitoring of stand dynamics in Białowieża Forest supported with remote sensing techniques"



Forest Research Institute
 Sękocin Stary, Braci Leśnej 3 St., 05-090 Raszyn
 Tel. +48 22 71 50 300; Fax +48 22 72 00 397
 e-mail: ibl@ibles.waw.pl; www.ibles.pl
 KRS: 0000039417; REGON: 000115832; NIP: 5250009200

ForBioSensing Design Office
 Sękocin Stary, Braci Leśnej 3 St., Building B., 230
 05-090 Raszyn
 Tel. +48 22 71 50 663
 e-mail: fbs-biuro@ibles.waw.pl



LIFE+ ForBioSensing PL Comprehensive monitoring of stand dynamics in Białowieża Forest supported with remote sensing techniques co-funded by Life Plus and The National Fund for Environmental Protection and Water Management in Poland, contract number LIFE13 ENV/PL/000048, 485/2014/WN10/OP-NM-LF/D

Deadwood in Białowieża Forest

(year 2019)

Appendix to Chapter 5 of the monograph: „Comprehensive monitoring of stand dynamics in Białowieża Forest using remote sensing data” (Published by IBL, Sękocin Stary, 2022)
Elaborated by: Ł. Kuberski, M. Mielcarek

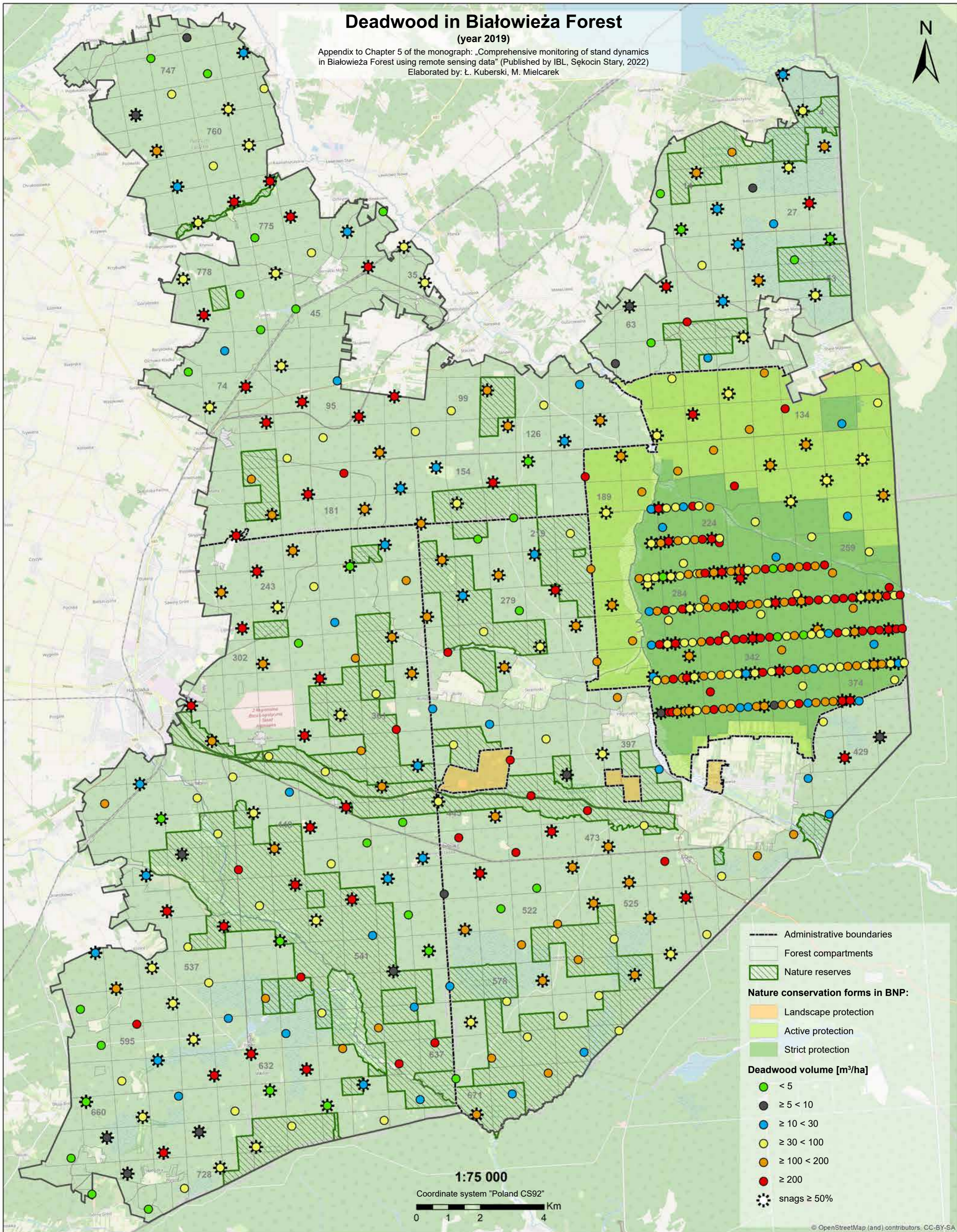

- Administrative boundaries
- ▭ Forest compartments
- ▨ Nature reserves
- Nature conservation forms in BNP:**
- ▭ Landscape protection
- ▭ Active protection
- ▭ Strict protection
- Deadwood volume [m³/ha]**
- < 5
- ≥ 5 < 10
- ≥ 10 < 30
- ≥ 30 < 100
- ≥ 100 < 200
- ≥ 200
- ☼ snags ≥ 50%

© OpenStreetMap (and) contributors. CC-BY-SA



The map has been created as a part of ForBioSensing LIFE+ project PL "Comprehensive monitoring of stand dynamics in Białowieża Forest supported with remote sensing techniques"



Forest Research Institute
Sękocin Stary, Braci Leśnej 3 St., 05-090 Raszyn
Tel. +48 22 71 50 300; Fax +48 22 72 00 397
e-mail: ibl@ibles.waw.pl; www.ibles.pl
KRS: 0000039417; REGON: 000115832; NIP: 5250009200

ForBioSensing Design Office
Sękocin Stary, Braci Leśnej 3 St., Building B., 230
05-090 Raszyn
Tel. +48 22 71 50 663
e-mail: fbis-biuro@ibles.waw.pl



LIFE+ ForBioSensing PL Comprehensive monitoring of stand dynamics in Białowieża Forest supported with remote sensing techniques co-funded by Life Plus and The National Fund for Environmental Protection and Water Management in Poland, contract number LIFE13 ENV/PL/000048, 485/2014/WN10/OP-NM-LF/D

Forest health status

(year 2019)

Elaborated by: A. Modzelewska, M. Mielcarek

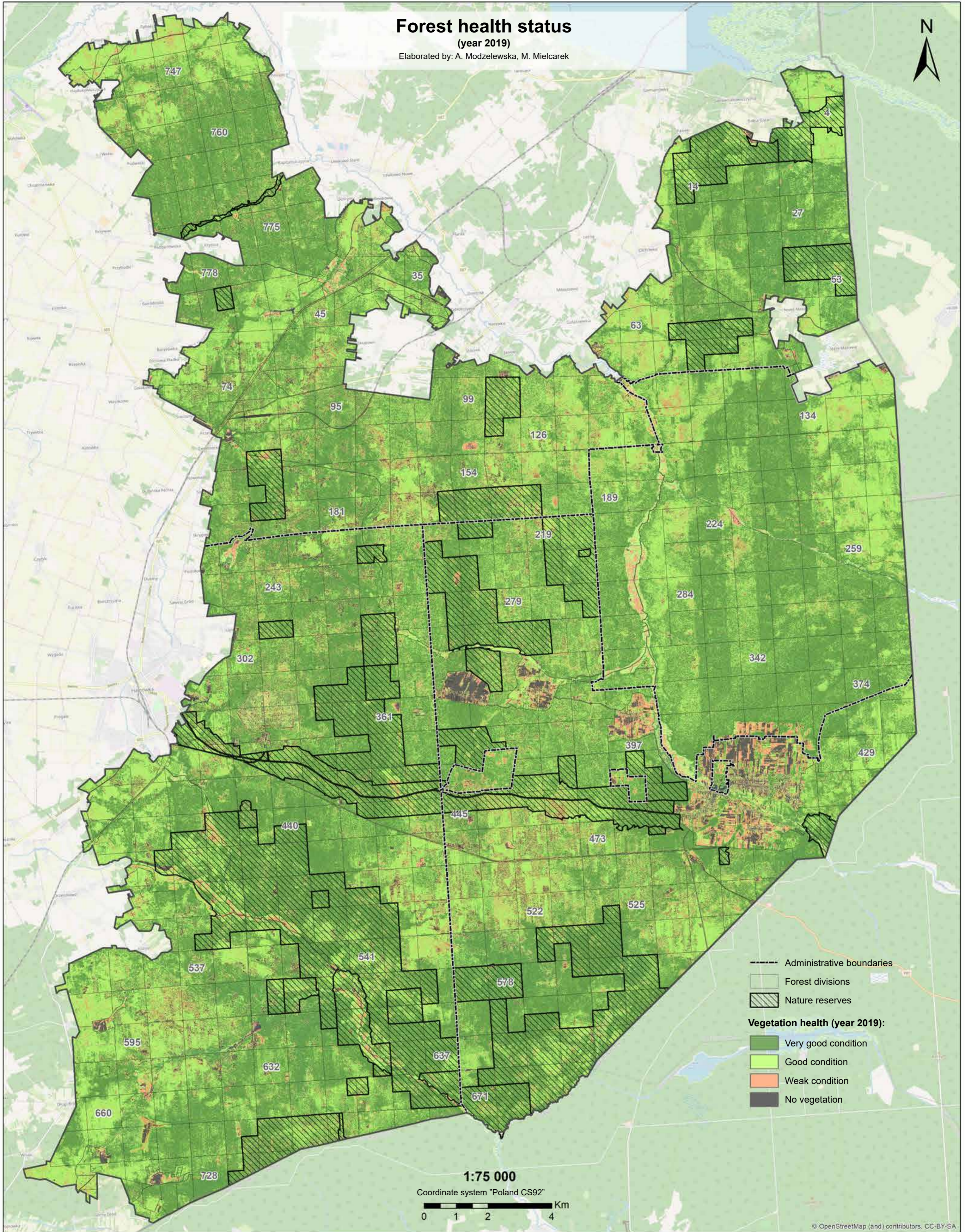

- Administrative boundaries
 - Forest divisions
 - ▨ Nature reserves
- Vegetation health (year 2019):**
- Very good condition
 - Good condition
 - Weak condition
 - No vegetation

1:75 000

Coordinate system "Poland CS92"



© OpenStreetMap (and) contributors. CC-BY-SA



The map has been created as a part of ForBioSensing LIFE+ project PL "Comprehensive monitoring of stand dynamics in Białowieża Forest supported with remote sensing techniques"



Forest Research Institute
Sękocin Stary, Braci Leśnej 3 St., 05-090 Raszyn
Tel. +48 22 71 50 300; Fax +48 22 72 00 397
e-mail: ibl@ibles.waw.pl; www.ibles.pl
KRS: 0000039417; REGON: 000115832; NIP: 5250009200

ForBioSensing Design Office
Sękocin Stary, Braci Leśnej 3 St., Building B., 230
05-090 Raszyn
Tel. +48 22 71 50 663
e-mail: fbs-biuro@ibles.waw.pl



LIFE+ ForBioSensing PL Comprehensive monitoring of stand dynamics in Białowieża Forest supported with remote sensing techniques co-funded by Life Plus and The National Fund for Environmental Protection and Water Management in Poland, contract number LIFE13 ENV/PL/000048, 485/2014/WN10/OP-NM-LF/D

Forest communities in Białowieża Forest

(year 2019)

Appendix to Chapter 15 of the monograph: „Comprehensive monitoring of stand dynamics in Białowieża Forest using remote sensing data” (Published by IBL, Sękocin Stary, 2022)
Elaborated by: J.M. Matuszkiewicz, R. Paluch, A. Szulc, M. Mielcarek, M. Lisiewicz, Ł. Kuberski, K. Stereńczak

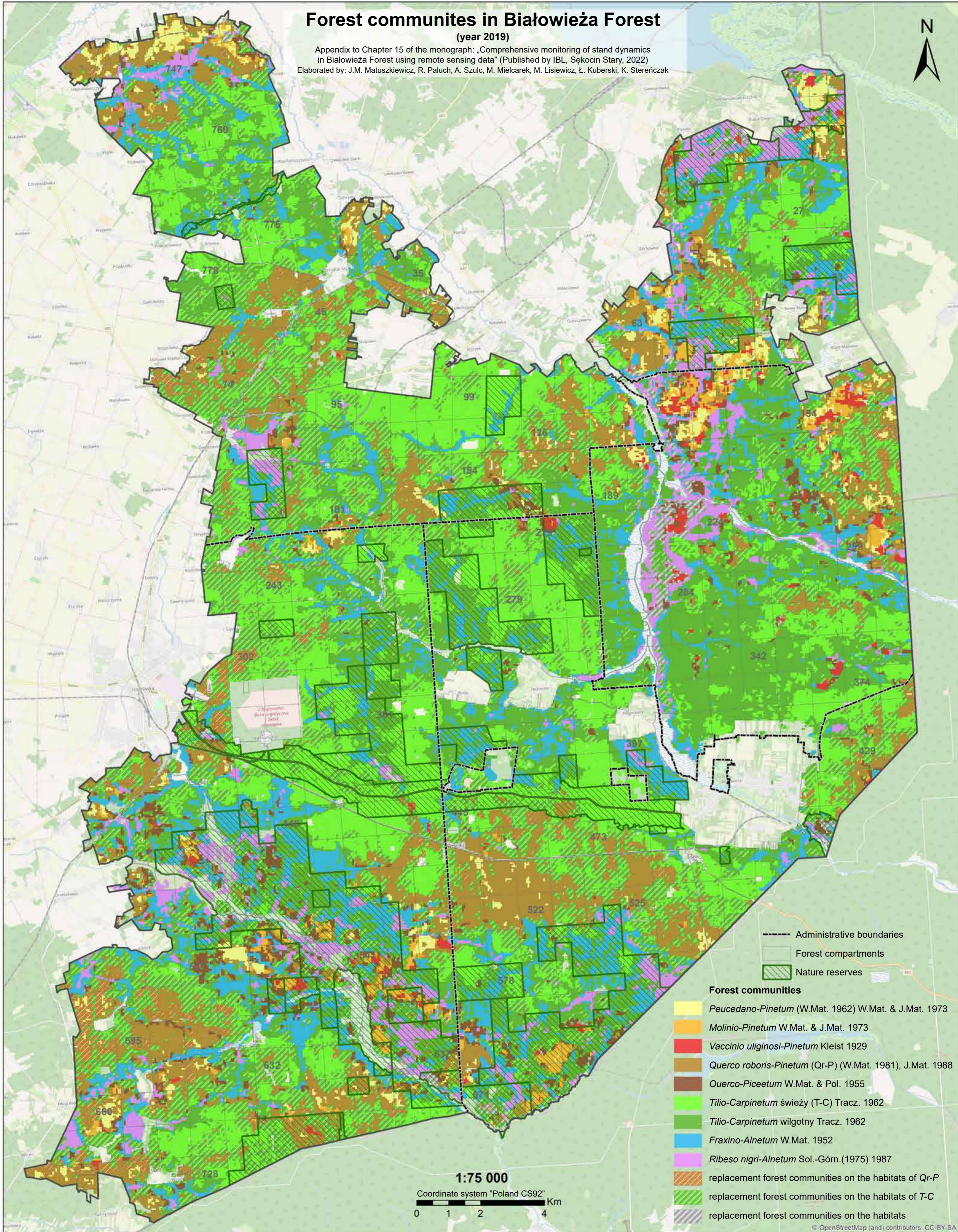

- Administrative boundaries
- Forest compartments
- ▨ Nature reserves

Forest communities

- Peucedano-Pinetum* (W.Mat. 1962) W.Mat. & J.Mat. 1973
- Molinio-Pinetum* W.Mat. & J.Mat. 1973
- Vaccinio uliginosi-Pinetum* Kleist 1929
- Quercu roboris-Pinetum* (Qr-P) (W.Mat. 1981), J.Mat. 1988
- Quercu-Piceetum* W.Mat. & Pol. 1955
- Tilio-Carpinetum* świeży (T-C) Tracz. 1962
- Tilio-Carpinetum* wilgotny Tracz. 1962
- Fraxino-Alnetum* W.Mat. 1952
- Ribeso nigri-Alnetum* Sol.-Górn.(1975) 1987
- replacement forest communities on the habitats of Qr-P
- replacement forest communities on the habitats of T-C
- replacement forest communities on the habitats

1:75 000

Coordinate system "Poland CS92"
0 1 2 4 Km

© OpenStreetMap (and) contributors. CC-BY-SA



The map has been created as a part of ForBioSensing LIFE+ project PL "Comprehensive monitoring of stand dynamics in Białowieża Forest supported with remote sensing techniques"



Forest Research Institute
Sękocin Stary, Braci Leśnej 3 St., 05-090 Raszyn
Tel. +48 22 71 50 300; Fax +48 22 72 00 397
e-mail: ibl@ibles.waw.pl; www.ibles.pl
KRS: 0000039417; REGON: 000115832; NIP: 5250009200

ForBioSensing Design Office
Sękocin Stary, Braci Leśnej 3 St., Building B., 230
05-090 Raszyn
Tel. +48 22 71 50 663
e-mail: fbs-biuro@ibles.waw.pl



LIFE+ ForBioSensing PL Comprehensive monitoring of stand dynamics in Białowieża Forest supported with remote sensing techniques co-funded by Life Plus and The National Fund for Environmental Protection and Water Management in Poland, contract number LIFE13 ENV/PL/000048, 485/2014/WN10/OP-NM-LF/D

Forest stand growing stock

(year 2019)

Appendix to Chapter 15 of the monograph: „Comprehensive monitoring of stand dynamics in Białowieża Forest using remote sensing data” (Published by IBL, Sękocin Stary, 2022)

Elaborated by: M. Mielcarek, K. Stereńczak, B. Kraszewski, A. Kamińska, Z. Piasecka, M. Lisiewicz, M. Białczak, A. Modzelewska, R. Sądowski, K. Kędra

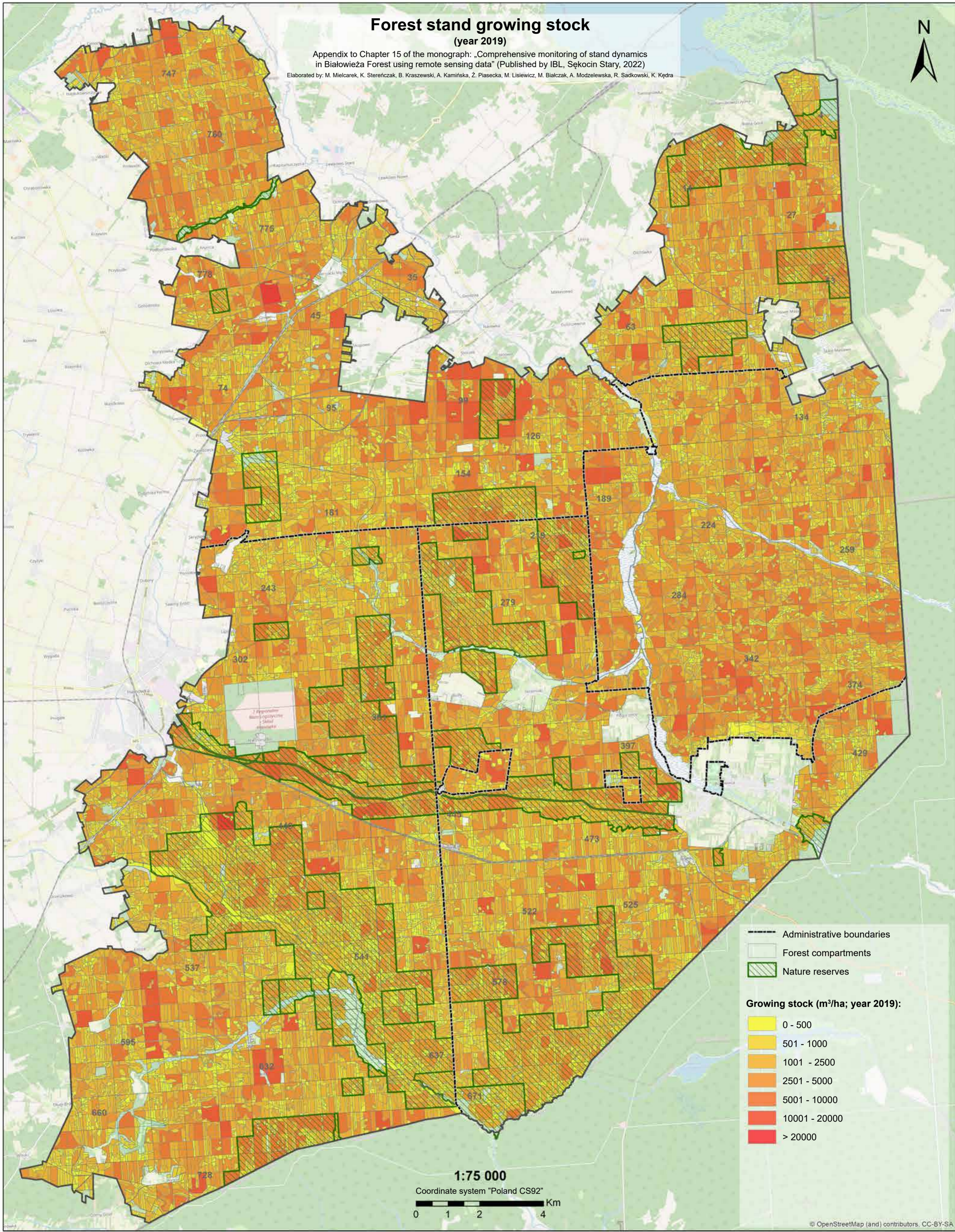

- Administrative boundaries
 - Forest compartments
 - Nature reserves
- Growing stock (m³/ha; year 2019):**
- 0 - 500
 - 501 - 1000
 - 1001 - 2500
 - 2501 - 5000
 - 5001 - 10000
 - 10001 - 20000
 - > 20000

1:75 000

Coordinate system "Poland CS92"



© OpenStreetMap (and) contributors, CC-BY-SA



The map has been created as a part of ForBioSensing LIFE+ project PL "Comprehensive monitoring of stand dynamics in Białowieża Forest supported with remote sensing techniques"



Forest Research Institute
Sękocin Stary, Braci Leśnej 3 St., 05-090 Raszyn
Tel. +48 22 71 50 300; Fax +48 22 72 00 397
e-mail: ibl@ibles.waw.pl; www.ibles.pl
KRS: 0000039417; REGON: 000115832; NIP: 5250009200

ForBioSensing Design Office
Sękocin Stary, Braci Leśnej 3 St., Building B., 230
05-090 Raszyn
Tel. +48 22 71 50 663
e-mail: fbis-biuro@ibles.waw.pl



LIFE+ ForBioSensing PL Comprehensive monitoring of stand dynamics in Białowieża Forest supported with remote sensing techniques co-funded by Life Plus and The National Fund for Environmental Protection and Water Management in Poland, contract number LIFE13 ENV/PL/000048, 485/2014/WN10/OP-NM-LF/D

Global solar radiation

(year 2019)

Appendix to Chapter 14 of the monograph: „Comprehensive monitoring of stand dynamics in Białowieża Forest using remote sensing data” (Published by IBL, Sękocin Stary, 2022)

Elaborated by: Ż. Piasecka, M. Mielcarek

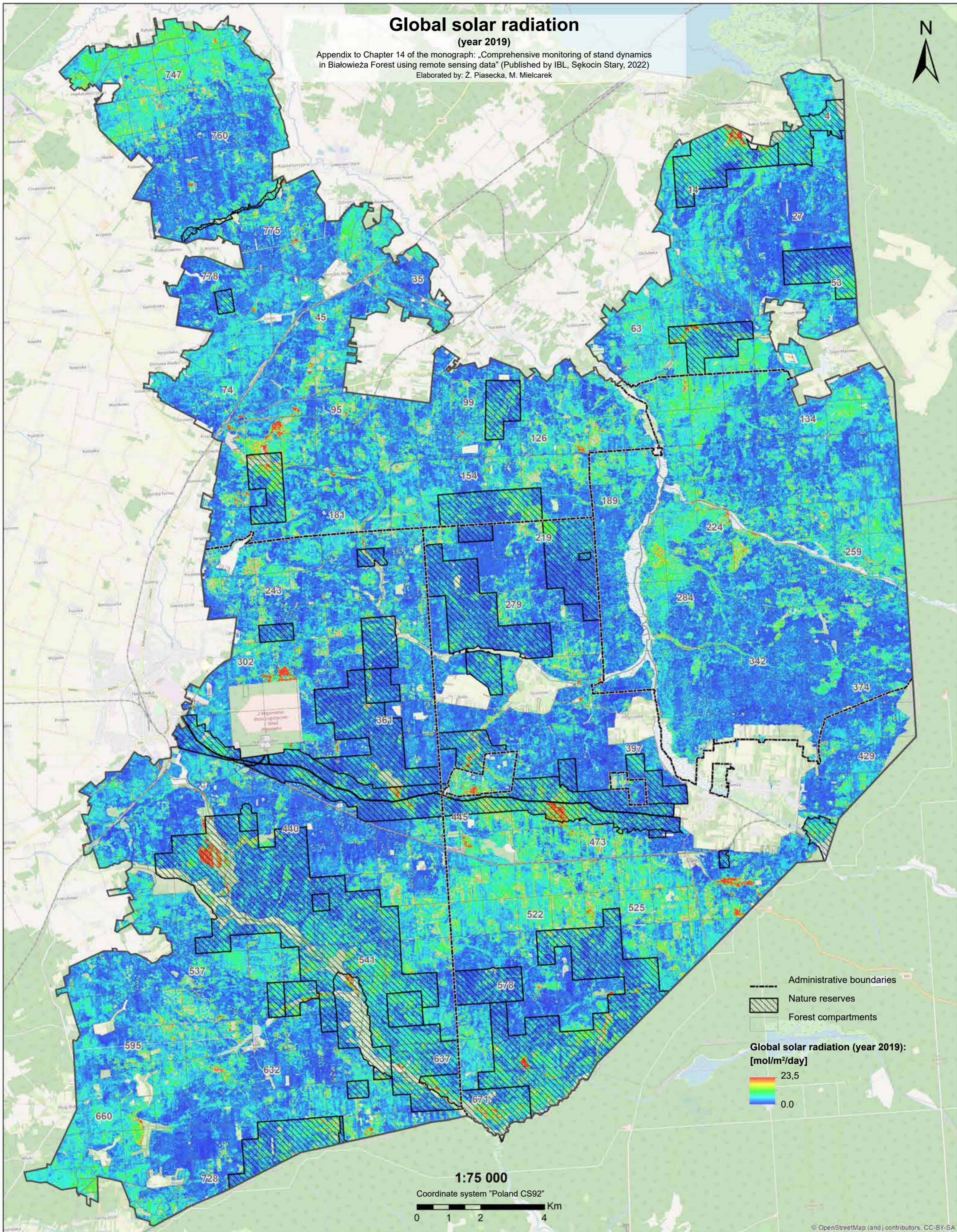

- Administrative boundaries
- ▨ Nature reserves
- ▭ Forest compartments

Global solar radiation (year 2019):
[mol/m²/day]

23.5
0.0

1:75 000

Coordinate system "Poland CS92"

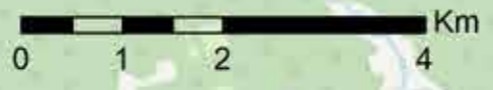

© OpenStreetMap (and) contributors. CC-BY-SA



The map has been created as a part of ForBioSensing LIFE+ project PL "Comprehensive monitoring of stand dynamics in Białowieża Forest supported with remote sensing techniques"



Forest Research Institute
Sękocin Stary, Braci Leśnej 3 St., 05-090 Raszyn
Tel. +48 22 71 50 300; Fax +48 22 72 00 397
e-mail: ibl@ibles.waw.pl; www.ibles.pl
KRS: 0000039417; REGON: 000115832; NIP: 5250009200

ForBioSensing Design Office
Sękocin Stary, Braci Leśnej 3 St., Building B., 230
05-090 Raszyn
Tel. +48 22 71 50 663
e-mail: fbs-biuro@ibles.waw.pl



LIFE+ ForBioSensing PL Comprehensive monitoring of stand dynamics in Białowieża Forest supported with remote sensing techniques co-funded by Life Plus and The National Fund for Environmental Protection and Water Management in Poland, contract number LIFE13 ENV/PL/000048, 485/2014/WN10/OP-NM-LF/D

The current state of Białowieża Forest based on the results of the LIFE+ForBioSensing project



Forest Research Institute

The current state of Białowieża Forest based on the results of the LIFE+ForBioSensing project

Sękocin Stary 2022

"So far, no papers with such broad scope - thematic, temporal, spatial and technological - concerning the Białowieża Forest, as adopted in the monograph, have been published in domestic and foreign literature [...]"

Krzysztof Będkowski, PhD. Eng.

"The monograph will undoubtedly constitute an important source of information about the ecosystems of the Białowieża Forest, and the contribution of the presented results to the knowledge is not negotiable [...]"

Professor Wojciech Grodzki, Ph.D.

"It should be emphasized not only the pioneering nature of many studies based on the use of data obtained with remote methods in relation to the Białowieża Forest site, but also their significant contribution to the development of the methodology of forest inventory research in general, on an international scale [...]"

Professor Bogdan Brzeziecki, Ph.D.



ForBioSensing LIFE+ project PL Comprehensive monitoring of stand dynamics in Białowieża Forest supported with remote sensing techniques is co-funded by the European Commission under European Union financial instrument LIFE+ and by the National Fund for Environmental Protection and Water Management

Agreement number with the EC: LIFE13 ENV/PL/000048;
Agreement number with the National Fund for Environmental Protection and Water Management: 485/2014/WN10/OP-NM-LF/D;